

## Operating manual

### DE46

Digital differential pressure switch / transmitter  
with colour-change LCD

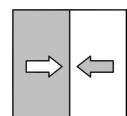

## Masthead

**Manufacturer:****FISCHER Mess- und Regeltechnik GmbH**Bielefelderstr. 37a  
32107 Bad SalzuflenTelephone: +49 5222 974 0  
Telefax: +49 5222 7170eMail: [info@fischermesstechnik.de](mailto:info@fischermesstechnik.de)web: [www.fischermesstechnik.de](http://www.fischermesstechnik.de)**Technical editorial team:**

Documentation representative: S. Richter

Technical editor: R.Kleemann

All rights, also those to the translation, reserved. No part of these instructions may be reproduced or processed, duplicated or distributed using electronic systems or any other form (print, photocopy, microfilm or another process) without the written consent of the company Fischer Mess- und Regeltechnik GmbH, Bad Salzuflen.

Reproduction for internal use is expressly allowed.

Brand names and procedures are used for information purposes only and do not take the respective patent situation into account. Great care was taken when compiling the texts and illustrations; nevertheless, errors cannot be ruled out. The company FISCHER Mess- und Regeltechnik GmbH will not accept any legal responsibility or liability for this.

Subject to technical amendments.

© FISCHER Mess- und Regeltechnik GmbH 2014



# Table of Content

<b>1 Safety instructions</b>	<b>4</b>
1.1 General	4
1.2 Personnel Qualification	4
1.3 Risks due to Non-Observance of Safety Instructions	4
1.4 Safety Instructions for the Operating Company and the Operator	4
1.5 Unauthorised Modification	4
1.6 Inadmissible Modes of Operation	5
1.7 Safe working practices for maintenance and installation work	5
1.8 Pictogram explanation	5
<b>2 Product and functional description</b>	<b>6</b>
2.1 Use as intended	6
2.2 Part designations	6
2.3 Function diagram	7
2.4 Design and mode of operation	7
<b>3 Installation</b>	<b>8</b>
3.1 General	8
3.2 Process connection	8
3.3 Electrical connection	9
<b>4 Commissioning</b>	<b>10</b>
4.1 General	10
4.2 Configuration	10
4.3 Control Elements	10
4.4 Menu levels	12
<b>5 Maintenance</b>	<b>23</b>
5.1 Maintenance	23
5.2 Transport	23
5.3 Service	23
5.4 Disposal	23
<b>6 Technical data</b>	<b>24</b>
6.1 Input variables	24
6.2 Output parameters	24
6.3 Measurement accuracy	24
6.4 Auxiliary energy	25
6.5 Application conditions	25
6.6 Construction design	25
6.7 Display and operating interface	28
<b>7 Order Codes</b>	<b>29</b>
7.1 Accessories	30
<b>8 Attachments</b>	<b>31</b>

# 1 Safety instructions

## 1.1 General

This operating manual contains basic instructions for the installation, operation and maintenance of the device that must be followed without fail. It must be read by the installer, the operator and the responsible specialist personnel before installing and commissioning the device.

This operating manual is an integral part of the product and therefore needs to be kept close to the instrument in a place that is accessible at all times to the responsible personnel.

The following sections, in particular instructions about the assembly, commissioning and maintenance, contain important information, non-observance of which could pose a threat to humans, animals, the environment and property.

The instrument described in these operating instructions is designed and manufactured in line with the state of the art and good engineering practice.

## 1.2 Personnel Qualification

The instrument may only be installed and commissioned by specialized personnel familiar with the installation, commissioning and operation of this product.

Specialized personnel are persons who can assess the work they have been assigned and recognize potential dangers by virtue of their specialized training, their skills and experience and their knowledge of the pertinent standards.

## 1.3 Risks due to Non-Observance of Safety Instructions

Non-observance of these safety instructions, the intended use of the device or the limit values given in the technical specifications can be hazardous or cause harm to persons, the environment or the plant itself.

The supplier of the equipment will not be liable for damage claims if this should happen.

## 1.4 Safety Instructions for the Operating Company and the Operator

The safety instructions governing correct operation of the instrument must be observed. The operating company must make them available to the installation, maintenance, inspection and operating personnel.

Dangers arising from electrical components, energy discharged by the medium, escaping medium and incorrect installation of the device must be eliminated. See the information in the applicable national and international regulations.

Please observe the information about certification and approvals in the Technical Data section.

## 1.5 Unauthorised Modification

Modifications of or other technical alterations to the instrument by the customer are not permitted. This also applies to replacement parts. Only the manufacturer is authorised to make any modifications or changes.

## 1.6 Inadmissible Modes of Operation

The operational safety of this instrument can only be guaranteed if it is used as intended. The instrument model must be suitable for the medium used in the system. The limit values given in the technical data may not be exceeded.

The manufacturer is not liable for damage resulting from improper or incorrect use.

## 1.7 Safe working practices for maintenance and installation work

The safety instructions given in this operating manual, any nationally applicable regulations on accident prevention and any of the operating company's internal work, operating and safety guidelines must be observed.

The operating company is responsible for ensuring that all required maintenance, inspection and installation work is carried out by qualified specialized personnel.

## 1.8 Pictogram explanation



### ⚠ DANGER

#### Type and source of danger

This indicates a **direct** dangerous situation that could lead to death or **serious injury** (highest danger level).

1. Avoid danger by observing the valid safety regulations.



### ⚠ WARNING

#### Type and source of danger

This indicates a **potentially** dangerous situation that could lead to death or **serious injury** (medium danger level).

1. Avoid danger by observing the valid safety regulations.



### ⚠ CAUTION

#### Type and source of danger

This indicates a **potentially** dangerous situation that could lead to slight or serious injury, damage or **environmental pollution** (low danger level).

1. Avoid danger by observing the valid safety regulations.



### NOTICE

#### Note / advice

This indicates useful information of advice for efficient and smooth operation.

## 2 Product and functional description

### 2.1 Use as intended

The DE46 is a multi-functional switching unit with an optional transmitter output. It is suitable for measuring overpressure, under-pressure and differential pressure in gaseous media. The device is to be exclusively used for the applications agreed between the manufacturer and the user.

#### Typical applications

- Filter equipment
- Precision air channel measurements
- Clean room pressure equalisation
- Burner under-pressure measurement
- Furnace circulating air control

#### Important features

- Long-term stable measurement of low pressure
- Robust, resistant to overpressure and maintenance-free
- Optional signal output with possibility of characteristic curve spread and reversal with any offset
- Characteristic curve implementation via table with max. 30 measuring points
- 4...6-digit LCD, full graphic, colour backlighting
- Complete adjustment of all parameters and measuring point protocol possible through optional PC adaptor EU03

### 2.2 Part designations

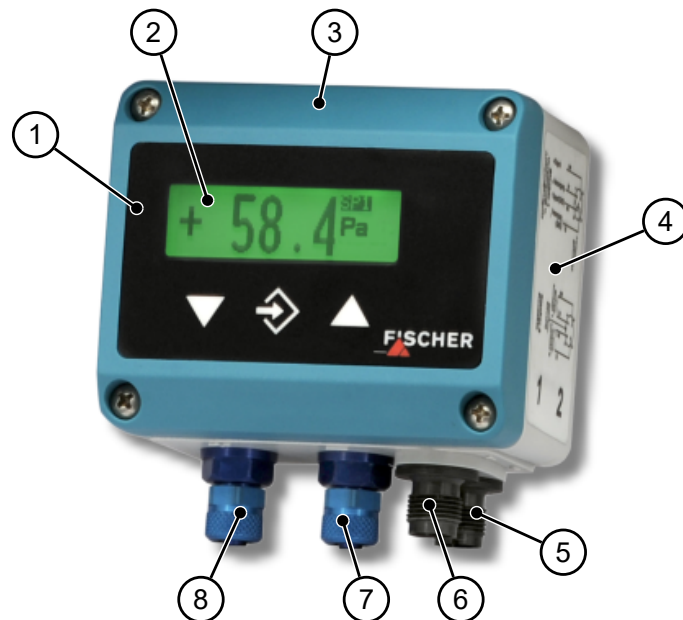

Fig. 1: DE46 with LCD

1	Membrane keyboard	2	LC display
3	Casing lid	4	Lower part of casing
5	M12 plug connector (connector 2)	6	M12 plug connector (connector 1)
7	Process connection (-)	8	Process connection (+)

### 2.3 Function diagram

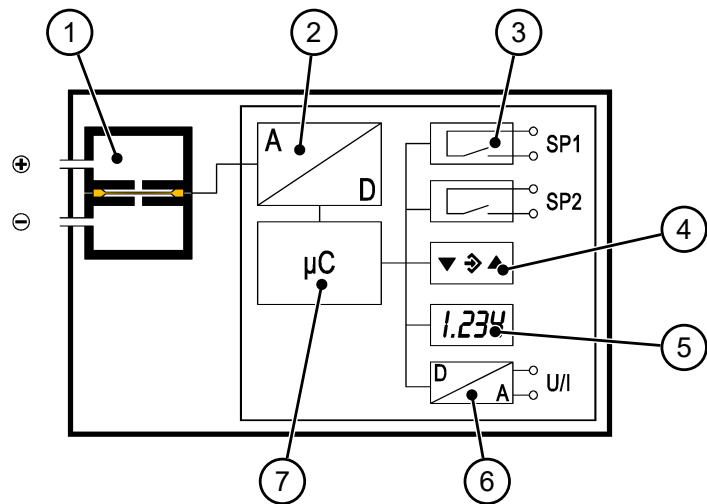

Fig. 2: Function diagram [DE46\_LCD]

1	Sensor element	2	Signal processing
3	Switching outputs	4	Membrane keyboard
5	LC display	6	Analogue output
7	Microcontroller		

### 2.4 Design and mode of operation

This switching device is based on a capacitive sensor element that is suitable for measuring overpressure, underpressure and differential pressure.

The measured pressure acts on the sensor element with a micromechanically produced differential condenser in silicon-glass technology.

Changes in pressure generate changes in capacity, which is evaluated by the device's electronics and transformed into signals on the display, switch contacts and an output signal.

## 3 Installation

### 3.1 General

The device is designed for installation onto flat assembly plates. For screw connection to the assembly plate, the device features four assembly bores on its back, which can be used for  $\varnothing$  3.5 mm tapping screws.

Optionally, the device can be delivered with a wall-mounting plate. This is also available as accessory.

At the factory, the device is calibrated for vertical installation, but the installation position is arbitrary. For any installation positions that are not vertical, the zero-point signal can be corrected via the installed offset correction.

The enclosure protection type IP 65 is only guaranteed, if a suitable power supply cable is used (see accessories).

If the device is intended for outdoor use, we recommend permanently protecting the membrane keypad against UV radiation and using a suitable enclosure or at least the erection of a sufficiently dimensioned canopy as a protection measure against constant rain or snow.

### 3.2 Process connection

- By authorized and qualified specialized personnel only.
- The pipes need to be depressurized when the instrument is being connected.
- Appropriate steps must be taken to protect the device from pressure surges.
- Check the suitability of the instrument for the media that is to be measured.
- Maximum pressures must be observed (cf. Tech. data)



#### **⚠ CAUTION**

**Do not blow into the pressure connections.**

This can damage the pressure sensor.

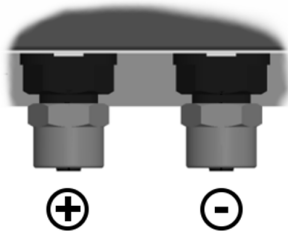

Fig. 3: Process connection

The pressure measuring lines must be installed on a gradient so that no water pockets for gas measurements can be created. If the required incline is not reached, water filters need to be installed at suitable points.

The pressure sensing lines need to be kept as short as possible and installed without sharp bends to avoid interfering delay times.

The pressure connections are marked with (+) and (-) symbols on the device. When the differential pressure is measured, the higher pressure is connected to the (+) side and the lower pressure to the (-) side.

If the pressure sensing lines are already pressurised at the time of commissioning, zero-point control and adjustment cannot be performed. In such cases, the device should be only connected to the mains without the pressure sensing lines.



### 3.3 Electrical connection

#### General

- By authorized and qualified specialized personnel only.
- When connecti the device, the relevant national and international electro-technical rules must be observed.
- Disconnect the system from the mains, before electrically connecting the device.
- Switch the consumer-adapted fuses.

The nominal supply voltage and the permissible range can be found in the technical data.

The admissible load / resistance for the signal output is stated in the technical data.

#### 3-wire connection

The device is connected as follows in a 3-wire switch:

The connection "Signal ground" (-Sig) is connected internally to the supply ground. It only serves as the ground connection for the output signal. This means that the output signal is free of interference levels on the power supply lines.

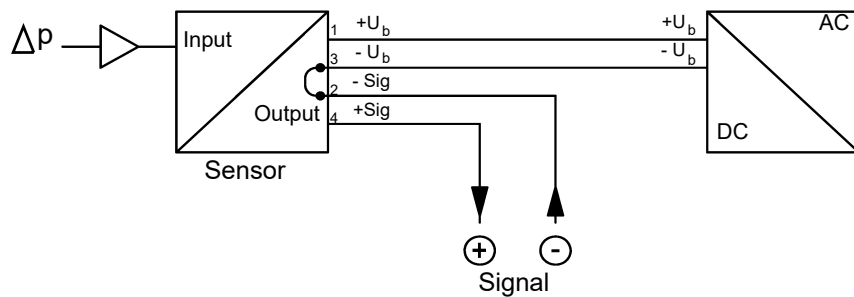

Fig. 4: 3L-switch with internal bridge -U<sub>b</sub> / -Sig

#### Connector 1: Supply and output signal

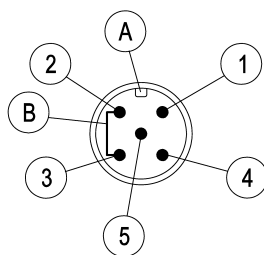

Fig. 5: M12 Plug 5-pin

Pos	Description	Cable colour
A	Coding A	
B	Internal bridge	
1	+U <sub>b</sub> Supply	brown
2	-Sig Signal	white
3	-U <sub>b</sub> Supply	blue
4	+Sig Signal	black
5	n.c.	

#### Connector 2: Switching outputs

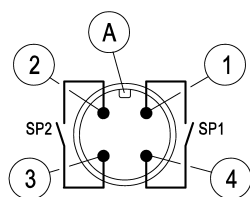

Fig. 6: M12 Plug 4-pin

Pos	Description	Cable colour
A	Coding A	
1	SP1 Switch point 1 (no)	brown
2	SP2 Switch point 2 (no)	white
3	SP2 Switch point 2 (com)	blue
4	SP1 Switch point 1 (com)	black

## 4 Commissioning

### 4.1 General

All electrical supply, operating and measuring lines, and the pressure connections must have been correctly installed before commissioning. All supply lines are arranged so that there are no mechanical forces acting on the device.

Check that the pressure connections do not leak before commissioning.

### 4.2 Configuration

During commissioning there are a number of setting options that allow the device to be adapted to the measuring point and measuring task. To facilitate the input, the individual parameters are placed into groups in so-called menu levels.

Depending on the device model some menu items are not available. For instance, no switch points can be set on a device without contacts.



### NOTICE

#### Parameter configuration on the PC

All the device settings can be made easily on the PC using the PC adapter. You will need a EU03 Transmitter PC Interface and the associated software TransPara for this. For more details, please refer to the Accessories section. The TransPara software makes all parameters directly visible and accessible. Also, the entire configuration can be loaded, saved and documented as a printout.

### 4.3 Control Elements

#### 4.3.1 LC display

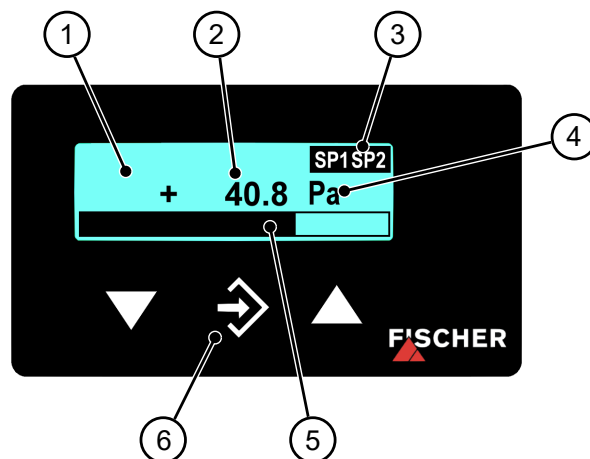

Fig. 7: LC display [DE46\_LCD]

1	LCD with back lighting	4	Unit
2	Measurement display 4...6 digits	5	Bar chart display
3	Status display of the switch points	6	Keyboard

In normal mode, the current measured value is shown on a 4-digit LC display. To show very large values, it is possible to switch to a 5 or 6-digit presentation (see Parameter MB decimal place [▶ 16]).

The unit is shown on the right of the display. If the device is equipped with contacts, a closed contact is always symbolised by an inverted text "SP1" or "SP2".

### SP1SP2

Fig. 8: Display SP1 SP2

Various colours can be selected for the back lighting. Depending on the measured value, the colour of the back lighting can be automatically changed. This can be used e.g. to depict good/poor differences. The back lighting can also be deactivated.

The measured value can also be shown in a bar chart. The measured value is also shown in smaller pictures as a number.

During the programming, the menu items and the associated parameters are shown on the display. The device continues to function whilst the parameters are being set; apart from one exception, the changes come into effect instantly. The exception here is a change of switching times - here the previously valid time must have run down.

### 4.3.2 Keyboard

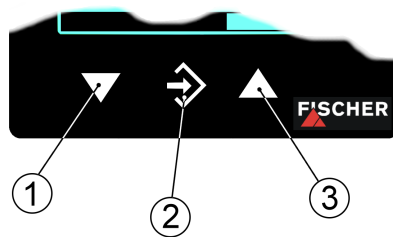

Fig. 9: Operating keys [LC display]

1	Page down menu	Reduce value
2	Call up menu	Save value
3	Page up menu	Increase value

The individual menu items and parameters can be displayed using the buttons ▲ and ▼. The respective menu item is selected or the parameters for making changes are called up via the button ⇨.

If a parameter can be changed, the display flashes. The change is made via the buttons ▲ and ▼. The value is saved with the button ⇨.

To leave a menu level or the entire menu, select the parameter "Menu level Quit" and press ⇨.

**Example:**

#### Switch-on point set switchpoint 1

In normal mode, press the button ⇨ to enter the menu. The menu level **Switch points** appears. Press the enter key ⇨ again to call up the display parameter.

The first parameter **SP 1 On** is displayed. To change this parameter, press the button ⇨ again.

The device jumps to the input:

- The parameter is stated in the 1st line.
- The value that is to be changed is shown in the 2nd line, the display flashes.
- The input limits are displayed in the 3rd line (if there is one).

The required value is set with the buttons ▲ and ▼ and then confirmed with ⇨.

## 4.4 Menu levels

The menu levels are structured as follows:

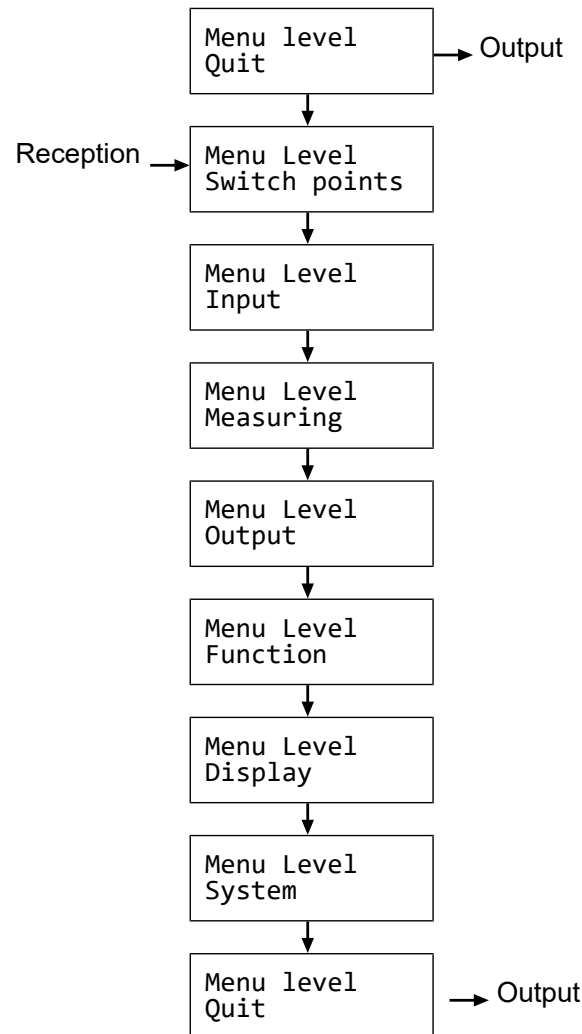

Fig. 10: Menu levels

The following tables provide an overview of the parameters of the individual menu levels. In the Menu Level System you can change to the respective national language using the language parameter. You can see which languages are supported there.

### 4.4.1 Menu Level Switch points

Parameter name	Description	Value range
<b>SP1 On</b>	Switch point 1 On	MRS-50% ... MRE+50%
<b>SP1 Off</b>	Switching point 1 off	MRS-50% ... MRE+50%
<b>SP1 Delay</b>	Switching point 1 delay	0...1800 s
<b>SP1 Function</b>	Switching point 1 function	NO, NC
<b>SP2 On</b>	Switch point 2 On	MRS-50% ... MRE+50%
<b>SP2 Off</b>	Switching point 2 off	MRS-50% ... MRE+50%
<b>SP2 Delay</b>	Switching point 2 delay	0...1800 s
<b>SP2 Function</b>	Switching point 2 function	NO, NC

The two switch outputs are configured by four parameters respectively. For the switch point 1 these are

- **SP1 On**
- **SP1 Off**
- **SP1 Delay**
- **SP1 Function**

Accordingly for switch point 2:

- **SP2 On**
- **SP2 Off**
- **SP2 Delay**
- **SP2 Function**

The function of the individual parameters is explained for both switch points using Switch point 1 as an example.

**SP1 On** defines the activation point, **SP1 Off** the deactivation point of switch output 1. The values are shown in the valid unit and set accordingly. The values are shown in the valid unit and set accordingly. Both parameters can be set independently over the entire value range.

The value range ranges from MRS – 50% to MRE + 50%. MRS stands for measuring range start and MRE for measuring range end.

#### Example:

#### Measurement range = 0 ... 100 Pa

The value range for this measuring range is -50 Pa ... +150 Pa.

Together, the two parameters **SP1 On** and **SP1 Off** determine the switch function of switch output 1:

- If **SP1 On** > **SP1 Off**, the output switches on, if the measured value exceeds SP1 On. It is only switched off again if the measured value SP1 Off is undercut (hysteresis function).
- If **SP1 On** = **SP1 Off**, the output switches on if the measured value exceeds SP1 On and off if the measured value undercuts the same value (SP1 Off).
- If **SP1 On** < **SP1 Off**, the output switches on, if the measured value lies within these switch points: i.e:  
**SP1 On** < Measured value < **SP1 Off** (window function).

**SP1 Delay** allows the reaction of the switch output to be delayed by between 0 and 1800 s. This parameter applies equally for switching on and off.

**SP1 Function** changes the function of the switch output 1. It is possible here to define whether the contact should work as a open contact (NO) or a break contact (NC).

#### 4.4.2 Menu Level Input

Parameter name	Description	Value range
<b>Absorption</b>	Attenuation, damping	0...100 s
<b>Offset corr.</b>	Offset correction	1/3 basic measuring range
<b>Zero-pt. wind.</b>	Zero-point window	1/3 basic measuring range

If there are unsteady pressure readings during operation, you can use the parameters **Absorption** and **Zero-pt. wind.** to stabilise the reading and the output signal.

The parameter **Absorption** functions like a capillary throttle. However, it only acts on the display, output signal and switch points (if these exist) but not on the measuring cell itself.

You can set the response time to pressure jumps in the range 0.0 to 100 s.



## NOTICE

### Response time

At maximum damping it can take over 2 minutes until the pressure jump from the nominal pressure 100% to 0% is also shown as zero in the display.

In many cases, unsteady readings are not a problem during normal operating mode, but this is not true for the idle state, i.e. if a measured value of zero is expected. The parameter **Zero-pt. wind.** is designed to solve this. Its value defines a range around zero at which the measured value is set to zero (see fig.).

The display only stops showing zero when the pressure leaves the set window. When twice the window value is reached, the measuring pressure and the display correspond again. This avoids jumps in the display.

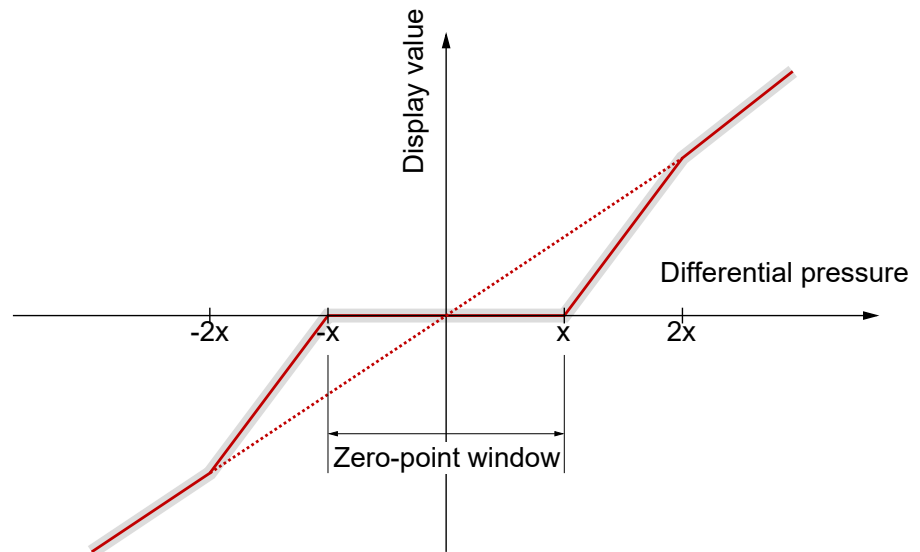

Fig. 11: Zero-point window

It makes sense to set the Offset (zero-point displacement) if, without differential pressure (remove measuring line), the display shows a value that is not zero. Before the offset correction, the zero-point window must be set to zero.

Select the **Offset corr.** parameter and correct the reading using the buttons ▲ or ▼ until zero is shown in the display.

When setting the offset, the current measured value is displayed. The zero-point window is not active during the offset setting.

### 4.4.3 Menu Level Measuring

Parameter name	Description	Value range
<b>MB start</b>	Measuring range start	Basic measuring range
<b>MB end</b>	Measuring range end	Basic measuring range
<b>Unit</b>	Measuring range unit	bar, mbar, Pa, kPa, MPa, psi, InWc, mmWs, mmHg
<b>Limit</b>	Measuring range limit	yes, no

The transmitter output signal primarily depends on the sensed pressure. However, you have the option of adjusting the output signal to a large extent to suit your requirements.



## NOTICE

### Adjustment of the output signal

The basic measuring range (indicated on the type label) and the type of output signal (voltage / current) are not variable.

The parameters **MB start** and **MB end** initially define the two pressures between which the output signal will change at all. Both values are adjustable across the entire basic measuring range. The set values also refer to the pressure in the respective unit. However, the signal values (current / voltage) for 'Start of measuring range' and 'End of measuring range' are fixed.

If **MB start** is smaller than **MB end**, this is called an increasing characteristic curve; the output signal increases as the pressure increases.

If **MB end** is smaller than **MB start**, this is a decreasing characteristic curve and the output signal decreases as the pressure increases.

The difference between the values **MB start** and **MB end** must be at least 25 % of the basic measuring range.

You can select a unit other than the unit of the basic measuring range with the parameter **Unit**. The user should remember however that not every unit is suitable. The conversion is automatic.

The parameter **Limit** allows the display, output and switching points to be limited to the range between Start of measuring range and End of measuring range. This makes sense when content is measured to avoid "negative contents". If Limit is set to "no", those measured values that are greater or smaller than the end values are shown.

#### 4.4.4 Menu Level Output

Parameter name	Description	Value range
<b>min. output</b>	min. output	
<b>max. output</b>	max. output	0.0 ... 21.0 mA or 0.0 ... 11.0 V
<b>Error signal</b>	Measuring range unit	

The parameters **min. output**, **max. output** and **error signal** define the limits of the output signal that may not be undercut or exceeded regardless of the pressure. The limit values take priority over the range defined by the **MB start** and **MB end** parameters! These parameters primarily serve to prevent error messages in downstream systems caused by brief overstepping of measuring ranges.

The parameter **min. output** is usually only used for devices with an output signal 4...20 mA because frequently values of below 3.8 mA are evaluated as error signals.

The **max. output** value can be used for the voltage and current to limit the maximum value.

The value defined via the parameter **Error signal** is issued if the device detects an internal error and can no longer work correctly. It should be noted here that not all potential errors and faults can be detected by the device itself.

### 4.4.5 Menu Level Function

The Function menu level is a variable menu whose appearance depends on the value of the Function parameter. There are linear, square rooted and table functions

#### Linear function

The input signal is linear before being sent to the display and the output. The range defined in the menu "Measuring" serves as the measuring range. If the function LINEAR is active, the other menu items are cancelled.

Parameter name	Description	Value range
<b>Function</b>	Function	<b>Value = linear</b>

#### Square rooted function

Here, the input signal is square rooted before being sent to the display and the output. This is necessary e.g. for flow measurements with differential pressure. A free unit can be defined for the display. To do this, the start and end of the display range and the number of decimal points are defined. It is also possible to define the unit with 4 characters.

Parameter name	Description	Value range
<b>Function</b>	Function	<b>Value = square rooted</b>
<b>MB decimal pl.</b>	Measuring range decimal places	1234, 123.4, 12.34, 1,234, 12345, 123456
<b>MB start</b>	Measuring range start	-9999 ... +9999
<b>MB end</b>	Measuring range end	-9999 ... +9999
<b>MB unit</b>	Measuring range unit	4 characters

The following section contains descriptions of the parameters **MB decimal pl.**, **MB start**, **MB end** and **MB unit** to describe the table function.

#### Tables function

This function allows free adjustment of the input variable to the display and output via a table with up to 30 support points. A value pair comprising a measured value and display value is issued for every support point.



## NOTICE

### Change of parameter

When switching from TABLE to another function, the table is initialised again and the existing values are lost.

Parameter name	Description	Value range
<b>Function</b>	Function	<b>Value = Table</b>
<b>MB decimal pl.</b>	Measuring range decimal places	1234, 123.4, 12.34, 1,234, 12345, 123456
<b>MB start</b>	Measuring range start	-9999 ... +9999
<b>MB end</b>	Measuring range end	-9999 ... +9999
<b>MB unit</b>	Measuring range unit	4 characters
<b>No. of pairs</b>	Number of pairs	n = 3...30
<b>Value pair1</b>	Value pair 1	MB-start ... MB-end
<b>Value pair2</b>	Value pair 2	
<b>Value pair3</b>	Value pair 3	
	...	
<b>Value pair30</b>	Value pair 30	



The display range is defined with the parameters **MB decimal pl.**, **MB start** and **MB end**. The user can select the configuration freely.

Using the parameter **MB decimal pl.**, it is possible to select between a 5 or 6-digit presentation. The resolution is not increased. Only an extra zero or two zeros are added. This serves the correct display of larger values. The measuring range must be positive for the 6 digit presentation.

The **MB unit** gives the user the option of defining a completely independent unit. Letters, numbers or special characters can be used. The unit can be max. 4 characters long.

If the function TABLE is selected, then it is also necessary to state the **No. of pairs**. It is defined here how many pairs of values (support points) are used in the table. A table is made up of at least 3, max. 30 support points.



## NOTICE

### Number of value pairs

If the number of value pairs is changed, the table is initialised again and the existing values are deleted.

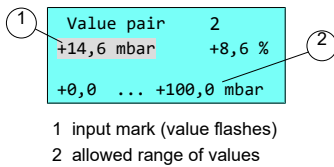

Fig. 12: Value pair

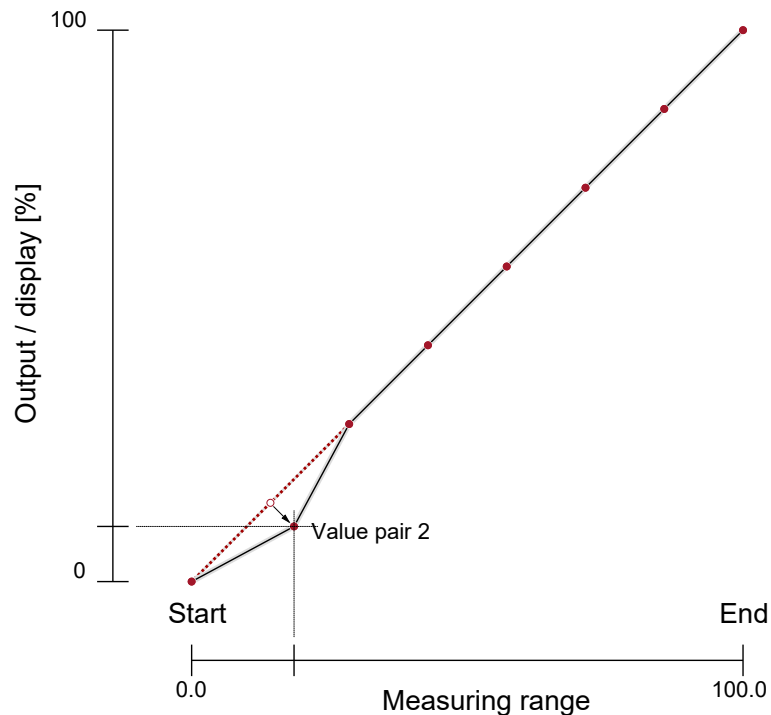

Fig. 13: Table function (example)

The individual value pairs can be seen and changed with the **Value pair1** to **Value pair30** parameters. A value pair comprises a measured value (left side) and a display value (right side). The measured value must lie within the measuring range and the display value must lie within the defined "free unit". The respective limits are shown during input. The table must contain either increasing or decreasing values. the table must contain either continuously increasing or continuously failing values. A change from an increasing to a decreasing characteristic curve within a support point table is not allowed.

#### 4.4.6 Menu Level Display

The Display menu level is a variable menu whose appearance depends on the value of the colour parameter. In addition to the various colours for the background lighting, there are also two auto-functions with colour switching available.

Parameter name	Description	Value range
<b>Colour</b>	Colour	Off, red, green, yellow, blue, pink, turquoise, white, <b>Auto1: Red-green</b> <b>Auto2: Red-yellow-green</b>
<b>Lighting</b>	Lighting time	0 s, 10 ... 600 s
<b>Contrast</b>	Contrast	15 ... 45
<b>Bar chart</b>	Barchart display	yes, no

The most important parameter is **Colour**. A fixed colour can be defined for the background colour here. There are also two auto-functions with colour switching available. Alternatively, the background illumination can be permanently deactivated.

If permanent lighting is not required, the parameter **Lighting time** can be used to define when the lighting should be switched off after the last time a button is pressed. In addition to permanent lighting (0 s), automatic shut-down after 10... 600 s is also possible. The set time is only valid if the parameter **Colour** is not set to "off".

Amongst other things, the legibility of the display depends on the temperature and the reading angle. To ensure optimised legibility, the display can be adjusted using the parameter **Contrast**. When the contrast is changed, it is possible that the display appears empty or almost completely black. In this case, the contrast must be turned up or down.

Via the parameter **Bar chart**, the display can be switched between a display where the measured value is either shown in large digits or the display shows small digits and an additional barchart.

##### Auto1: Colour-change red to green

In the mode with the automatic colour switchover, it is possible to enter the required switch thresholds "red-green switchover", "green-red switchover".

The switching thresholds can be moved within the measuring range. The series of switch points cannot be altered.

Parameter name	Description	Value range
<b>Red-Gr. switch.</b>	Red-green switching	MRS - 50% ...
<b>Gr-Red switch.</b>	Green-red switching	MRE + 50%
<b>Hysteresis</b>	Hysteresis	0.1 ... 10.0 %
<b>Delay</b>	Delay	0 ... 1800 s
<b>Colour</b>	Colour	Off, red, green, yellow, blue, pink, turquoise, white, <b>Auto1: Red-green</b> <b>Auto2: Red-yellow-green</b>
<b>Lighting</b>	Lighting time	0 s, 10 ... 600 s
<b>Contrast</b>	Contrast	15 ... 45
<b>Bar chart</b>	Barchart display	yes, no

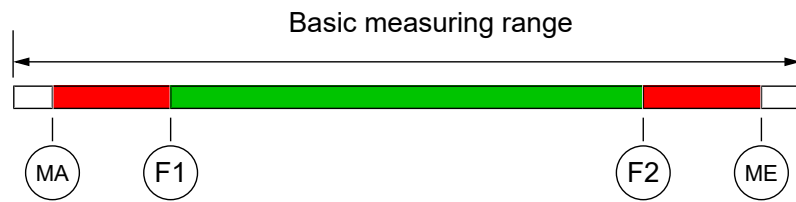

Fig. 14: Function Auto1

MA	<b>MB-start</b>	Measuring range start
F1	<b>Red-Gr. switch.</b>	Red-green switching
F2	<b>Gr-Red switch.</b>	Green-red switching
ME	<b>MB-end</b>	Measuring range end

The parameter **Hysteresis** can be used to prevent fast and unwanted colour changes. The hysteresis is set in the range 0.1... 10%.



## NOTICE

### Overlapping colour areas

Note: In the case of large hysteresis values, steps must be taken to ensure that the ranges of the individual colours do not overlap. Otherwise it is possible that the colour change may not function in the desired way.

The parameter **Delay** offers a further option to prevent unwanted colour changes. The colour change here can be delayed between 0...1800 s.

The parameter **Lighting** can be used to define when the lighting should be switched off after the last time a button is pressed. In addition to permanent lighting, automatic shut-down after 10...600 s is also possible. The set time is only valid if the parameter **Colour** is not set to "off". The lighting can be switched on permanently with the value 0s.

The legibility of the display can be adjusted using the parameter **Contrast**. When the contrast is changed, it is possible that the display appears empty or almost completely black. In this case, the contrast must be turned up or down again.

Via the parameter **Bar chart**, the display can be switched between a display where the measured value is either shown in large digits or the display shows small digits and an additional bar chart.

## Auto2: Colour-change red-yellow-green

In the Auto 2 mode with the automatic colour switchover, it is possible to enter the required switch thresholds "red-yellow switchover", "yellow-green switchover", "green-yellow switchover", "yellow-red switchover".

The switching thresholds can be moved within the measuring range. The series of switch points cannot be altered.

Parameter name	Description	Value range
<b>Red-Yell.switch.</b>	Red-yellow switchover	MRS - 50% ... MRE + 50%
<b>Yell.-Gr.switch.</b>	Yellow-green switchover	
<b>Gr.-Yell. switch</b>	Green-yellow switchover	
<b>Yell.-Red switch</b>	Yellow-red switchover	
<b>Hysteresis</b>	Hysteresis	0.1 ... 10.0 %
<b>Delay</b>	Delay	0 ... 1800 s
<b>Colour</b>	Colour	Off, red, green, yellow, blue, pink, turquoise, white, <b>Auto1: Red-green</b> <b>Auto2: Red-yellow-green</b>
<b>Lighting</b>	Lighting time	0 s, 10 ... 600 s
<b>Contrast</b>	Contrast	15 ... 45
<b>Bar chart</b>	Barchart display	yes, no

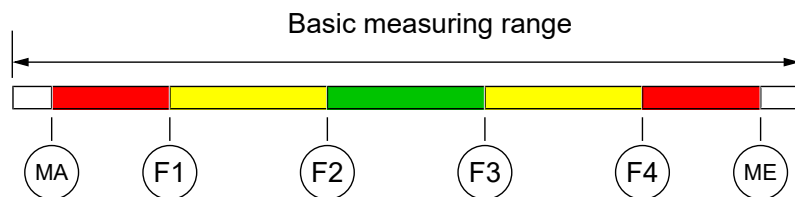

Fig. 15: Function Auto2

MA	<b>MB-start</b>	Measuring range start
F1	<b>Red-Yell.switch.</b>	Colour-change red to yellow
F2	<b>Yell.-Gr.switch.</b>	Colour-change yellow to green
F3	<b>Gr.-Yell. switch</b>	Colour-change green to yellow
F4	<b>Yell.-Red switch</b>	Colour-change yellow to red
ME	<b>MB-end</b>	Measuring range end

In this menu the same parameters are used as those described in the previous sections.



## NOTICE

### Unused range

If a range is not to be used, the associated switch thresholds (F1...F4) can be set to the same value.

### Example

The parameter Colour is set to Auto2. Only the green, yellow and red ranges are required here. To fade out the lower ranges red and yellow, the switch thresholds "red-yellow switching" and "yellow-green switching" are set to the start of the measuring range.

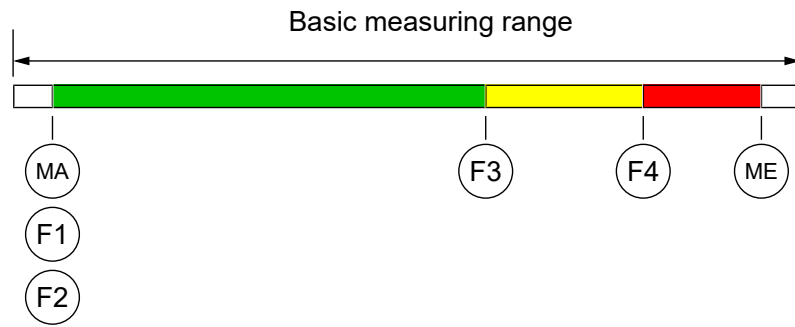

Fig. 16: Example Auto2

#### 4.4.7 Menu Level System

Parameter name	Description	Value range
<b>Language</b>	Language change	DE, EN, FR, ES, IT,PT,HU
<b>Software Info</b>	Information about the software	Device type, serial number, firmware version
<b>Config. Info</b>	Information about the configuration	Basic measuring range, output signal, contacts
<b>Statistics</b>	Statistics	Operating time, switch cycles of the contacts
<b>Password</b>	Password	0/1...999
<b>Load config.</b>	Load configuration	
<b>Save config.</b>	Save configuration	

The user menu can be switched to German, English, French, Spanish, Italian, Portuguese or Hungarian using the parameter **Language**.

The menu items **Software Info** and **Config. Info** provide information about the device. This information helps to answer questions about the device quickly.

- The serial number and the firmware version is shown in **Software info**. If a 'designation' has been assigned, this is also issued. Please note that a 'designation' can only be entered with the PC software by remote configuration.
- The basic measuring range, the defined output signal and existing contacts are stated in the **Config. Info**.

The **Statistics** provide information about the operating time and the relay switching cycles from the time of delivery. The operating time is shown in days (d) and hours (h)

A **Password** can be used to protect the menu against unauthorised access. The password is a figure from 1 to 999. The input 0 means that no password is active.

The password needs to be set if the user presses the button in normal mode to enter the menu. If a wrong password is entered, the system automatically jumps back to normal mode again. If no password is active, the display immediately jumps to the menu.



## NOTICE

### Forgotten password

The user cannot restore a forgotten password. Please contact the manufacturer in this case.

The user can load a saved configuration via the menu item **Load config**. This means that a functional set of parameters can be loaded after trying out various settings.

The menu item **Save config** serves to save the existing parameters in a protected memory area. This is helpful if the settings of a functional device needs to be optimised. **Save config** and **Load config** can be used to quickly restore the initial status again.



## NOTICE

### Delivery condition

If the user has not yet saved a configuration, the default values (status on delivery) are loaded. In this case, any measuring range spreads or switch points are reset and the device needs to be newly configured.

## 5 Maintenance

### 5.1 Maintenance

The instrument is maintenance-free. We recommend the following regular inspection to guarantee reliable operation and a long service life:

- Check the function in combination with downstream components.
- Check the leak-tightness of the pressure connection lines.
- Check the electrical connections.

The exact test cycles need to be adapted to the operating and environmental conditions. In combination with other devices, the operating instructions for the other devices also need to be observed.

### 5.2 Transport

The measuring device must be protected against impacts. It should be transported in the original packaging or a suitable transport container.

### 5.3 Service

All defective or faulty devices should be sent directly to our repair department. Please coordinate all shipments with our sales department.



#### **WARNING**

##### **Process media residues**

Process media residues in and on dismantled devices can be a hazard to people, animals and the environment. Take adequate preventive measures. If required, the devices must be cleaned thoroughly.

Return the device in the original packaging or a suitable transport container.

### 5.4 Disposal

Please help to protect the environment by always disposing of the work pieces and packaging materials in compliance with the valid national waste and recycling guidelines or reuse them.

## 6 Technical data

Please also observe the order code here.

### 6.1 Input variables

Measuring variable	: Differential pressure for gas-like media
Static operating pressure	: Max. 100 kPa
Bursting pressure	: Max. 170 kPa
Measurement range [Pa]	0...25
	0...50
	0...100
	0...250
	0...500
	0...1000
	-25...+25
	-50...+50
	-20...+80
	-100...+100

### 6.2 Output parameters

Output signal	Signal range	Load
0 ... 20 mA	0,0 ... 21,0 mA	$U_b \leq 26 \text{ V}: R_L \leq (U_b - 4 \text{ V}) / 0,02 \text{ A}$
4 ... 20 mA		$U_b > 26 \text{ V}: R_L \leq 1100 \Omega$
0 ... 10V	0,0 ... 11,0 V	$R_L > 2000 \Omega$

#### Switching outputs:

2 potential-free relay contacts

2 potential-free semiconductor switches (MOSFET)

	Relay	MOSFET
Progr. switching function	Open contact (NO) Break contact (NC)	Single-pole on switch (NO) Single-pole off switch (NO)
Max. switching voltage	32 V AC/DC	3...32 V AC/DC
Max. switching current	2 A	0,25 A
Max. switching capacity	64 W / VA	8 W / VA $R_{ON} \leq 4 \Omega$

### 6.3 Measurement accuracy

#### Characteristic curve deviation: (Non-linearity and hysteresis)

Maximum	1,0 % FS
Typical	0,5 % FS
Reproducibility	0,1 % FS

FS (Full Scale) refers to the basic measuring range.

The specifications refer to a linear, non-spread characteristic curve at 25 °C and apply to all measuring ranges.

#### Temperature coefficient: max. 0,6 % FS / 10K

in zero and span referred to the basic measuring range (not spread), compensation range 4...50 °C.



## 6.4 Auxiliary energy

Rated voltage	24 V AC/DC
Permissible operating voltage $U_b$	20 ... 32 V AC/DC
Power consumption	Typ. 2.2 W / Max. 3.5 W

## 6.5 Application conditions

Ambient temperature	-10 ... +70 °C
Medientemperatur	-10 ... +70 °C
Storage temperature	-20 ... +70 °C
Enclosure protection class	IP65 according to EN 60529
EMV	EN 61326-1:2013 EN 61326-2-3:2013
RoHS	EN IEC 63000:2018

## 6.6 Construction design

### Process connection

2x aluminium hose fitting for 6/4 mm or 8/6 mm hose.

2x pneumatic plug-in connection for 6/4 mm or 8/6 mm hose.

### Materials

Housing	Polyamide (PA) 6.6
Contact with the media	Silicon, PVC, aluminium, brass

### Assembly

Attachment boreholes on the rear for mounting on level mounting plates.

Wall mounting using the wall mounting plate.

Panel installation using the panel mounting set.

Assembly of the mounting rails using an adapter.

### 6.6.1 Dimensional drawings

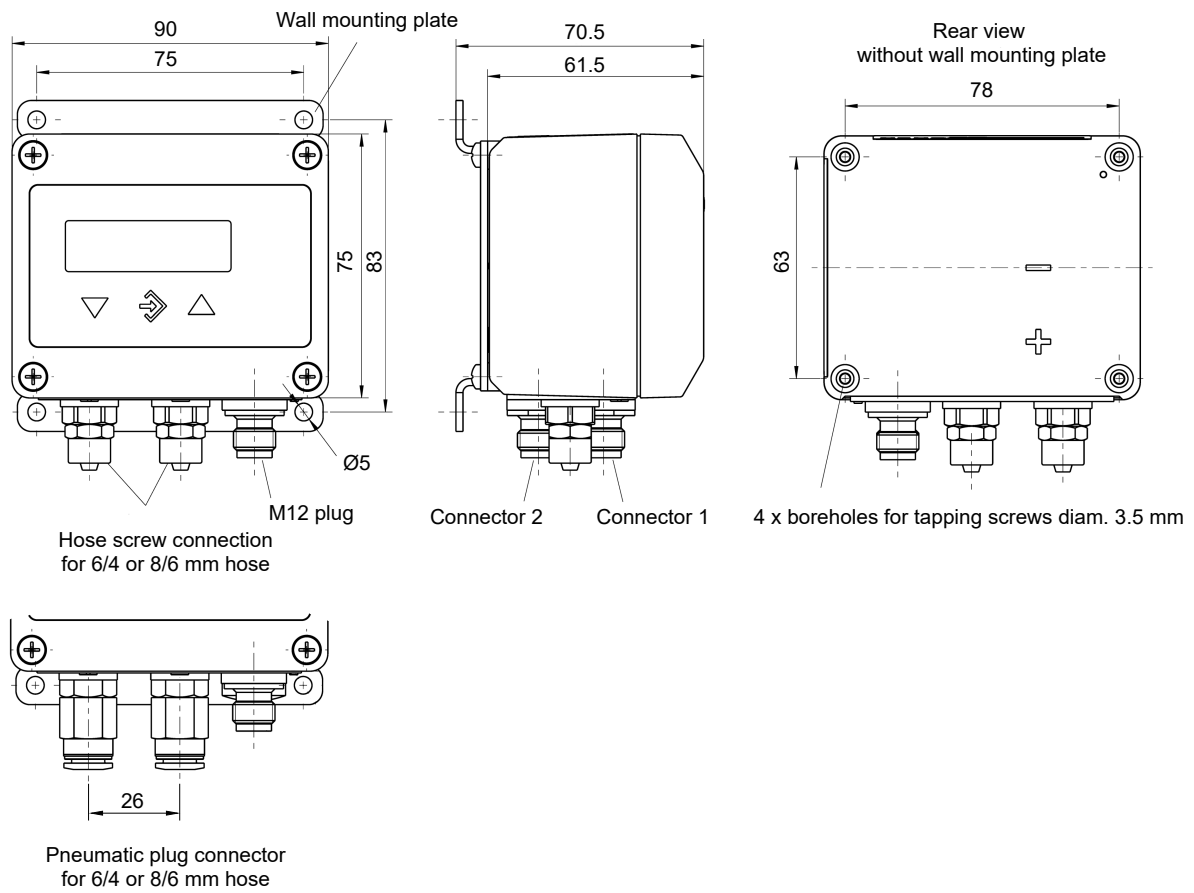

Fig. 17: Wall mounting

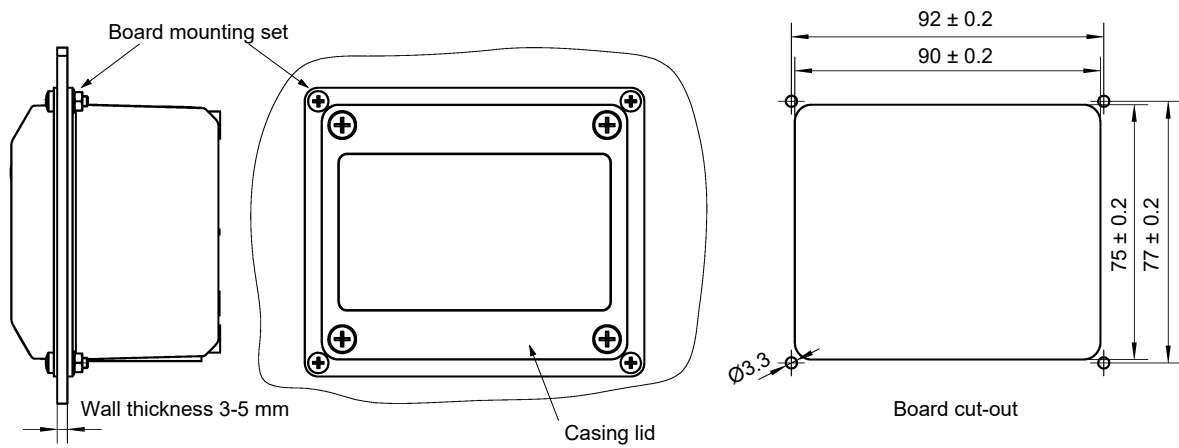
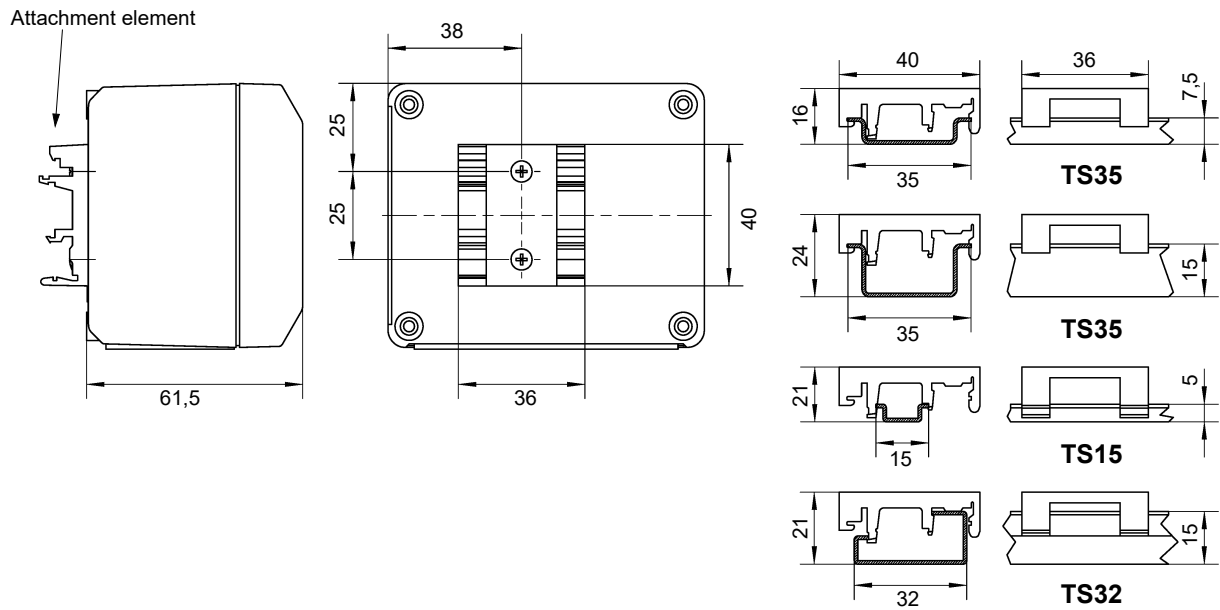

Fig. 18: Front panel mounting



### Panel installation

The DE46 is suitable for flush mounting in a FISCHER RT series panel. The installation is carried out ex works.

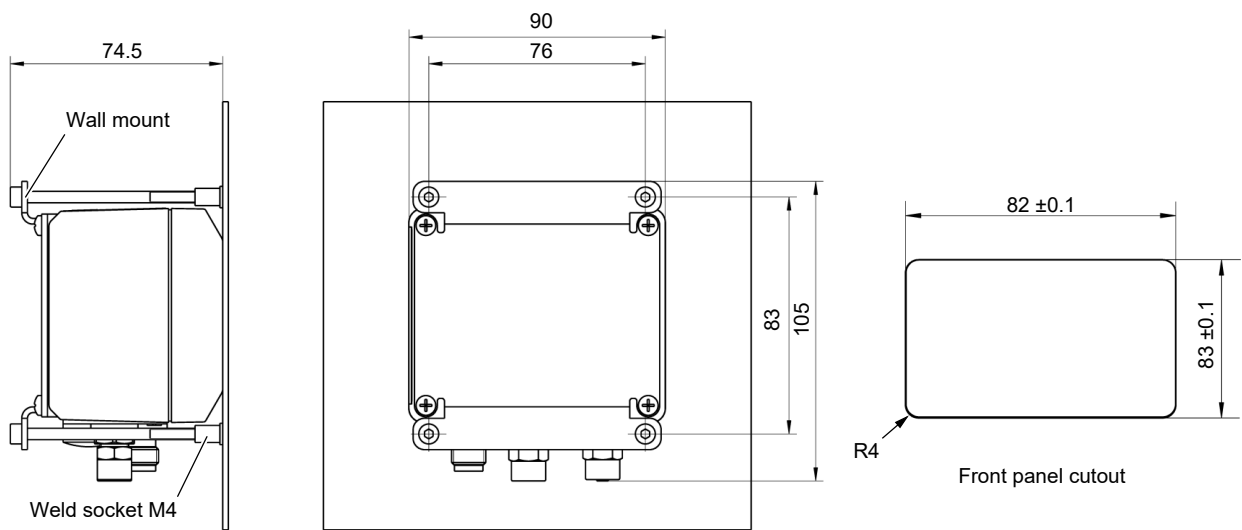

Fig. 19: Panel installation

## 6.7 Display and operating interface

4...6-digit LCD, full graphic, colour backlighting

Programming	
Attenuation	0.0...100.0s (jump response 10/90%)
Switch output	Switch-off point, switch-on point, response time (0...1800s), function (NC / NO contact)
Measuring range unit	m / Pa / "free unit", starting value, end value and decimal point for "free unit"
Output signal	User-definable within the basic measuring range <sup>(1)</sup>
Zero-point stabilising	0...1/3 of the basic measuring range <sup>(2)</sup>
Zero point correction	±1/3 of the basic measuring range <sup>(3)</sup>
Implementation of characteristic curve	linear, square rooted, table with 3...30 support points
Password	001 ... 999 (000 = no password protection)

(1) Max. effective spread 4:1

(2) measured values around zero are set to zero.

(3) To compensate different installation positions.

## 7 Order Codes

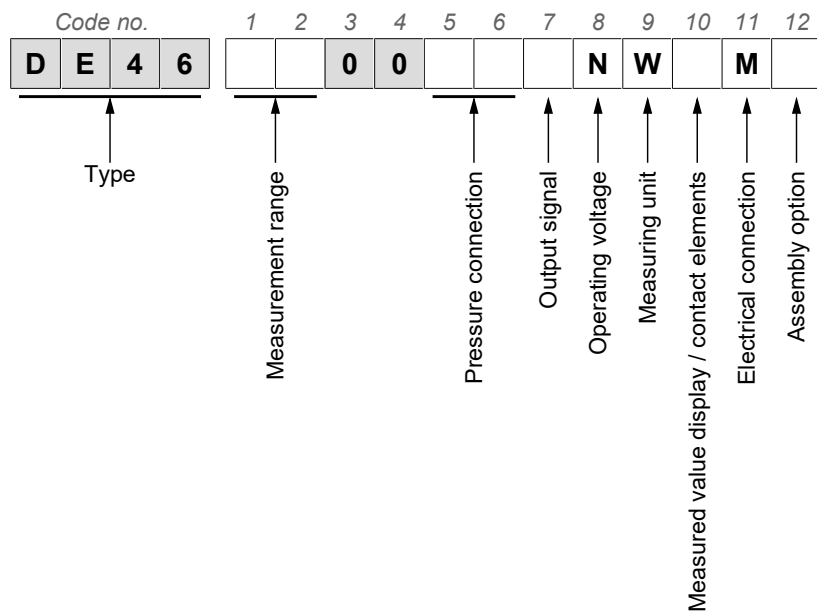

### [1,2] Measuring range

D1	0 ... 25 Pa
J6	0 ... 50 Pa
D4	0 ... 100 Pa
D6	0 ... 250 Pa
J7	0 ... 500 Pa
D9	0 ... 1000 Pa
L5	-25 ... +25 Pa
L2	-50 ... +50 Pa
L0	-20 ... +80 Pa
L7	-100 ... +100 Pa

### [5,6] Pressure connection

40	Aluminium screw connection for 6/4 mm hose
41	Aluminium screw connection for 8/6 mm hose
P6	Pneumatic plug connector for 6/4 mm hose
P8	Pneumatic plug connector for 8/6 mm hose

### [7] Output signal

0	without analogue output signal
A	0 ... 20 mA (3-wire)
P	4 ... 20 mA (3-wire)
C	0 ... 10 V (3-wire)

### [8] Operating voltage

N	24 V AC/DC
---	------------

<b>[9] Measuring unit</b>
<b>W</b> Selectable pressure units
<b>[10] Measured value display /contact elements</b>
<b>C</b> Colour change LCD - 2 relay contacts
<b>D</b> Colour change LCD - 2 semiconductor switches
<b>[11] Electrical connection</b>
<b>M</b> M12 plug connection
<b>[12] Assembly option</b>
<b>0</b> Attachment boreholes on rear side (standard)
<b>P</b> Panel assembly (flush front-mounted into a FISCHER panel)
<b>S</b> Assembly on mounting rails
<b>T</b> Panel mounting set
<b>W</b> Wall-mounting

## 7.1 Accessories

Order no.	Planned measures	No. of Poles	Length
06401993	M12 Connection cable for switching outputs	4-pin	2 m
06401994	M12 Connection cable for switching outputs	4-pin	5 m
06401563	M12 Connection cable for switching outputs	4-pin	7 m
06401572	M12 Connection cable for switching outputs	4-pin	10 m
06401995	M12 Connection cable for supply/signal	5-pin	2 m
06401996	M12 Connection cable for supply/signal	5-pin	5 m
06401564	M12 Connection cable for supply/signal	5-pin	7 m
06401573	M12 Connection cable for supply/signal	5-pin	10 m

### Remote configuration

Order no.		
EU05 0000	Transmitter PC interface incl. PC software	without battery
EU05 0001	Transmitter PC interface incl. PC software	With battery

A data sheet is available on our website [www.fischermesstechnik.de](http://www.fischermesstechnik.de) or on request.

# 8 Attachments

## 8.1 EC Declaration of conformity



(Translation) **CE**

### EU Declaration of Conformity

For the product described as follows

**Product designation**                      **Digital differential pressure transmitter / switch with colour change LCD**

**Type designation**                            **DE46**

it is hereby declared that it corresponds with the basic requirements specified in the following designated directives:

- |               |   |
|---------------|---|
| 2014/30/EU    | EMC Directive   |
| 2011/65/EU    | RoHS Directive  |
| (EU) 2015/863 | Delegated Directive amending Annex II to Directive 2011/65/EU |

The products were tested in compliance with the following standards.

- |   |  |
|---|--|
|   | <b>Electromagnetic compatibility (EMC)</b>   |
| <i>DIN EN 61326-1:2013-07</i><br><i>EN 61326-1:2013</i>     | <i>Electrical equipment for measurement, control and laboratory use - EMC requirements - Part 1: General requirements</i>  |
| <i>DIN EN 61326-2-3:2013-07</i><br><i>EN 61326-2-3:2013</i> | <i>Electrical equipment for measurement, control and laboratory use - EMC requirements - Part 2-3: Particular requirements - Test configuration, operational conditions and performance criteria for transducers with integrated or remote signal conditioning</i> |
|   | <b>RoHS Richtlinie (RoHS3)</b>   |
| <i>DIN EN IEC 63000:2019-05</i><br><i>EN IEC 63000:2018</i> | <i>Technical documentation for the assessment of electrical and electronic products with respect to the restriction of hazardous substances</i>  |

Also they were subjected to the conformity assessment procedure „**Internal production control**“.

Sole responsibility for the issue of this declaration of conformity in relation to fulfilment of the fundamental requirements and the production of the technical documents is with the manufacturer.

**Manufacturer**                                      **FISCHER Mess- und Regeltechnik GmbH**  
 Bielefelder Str. 37a  
 32107 Bad Salzufflen, Germany  
 Tel. +49 (0)5222 974 0

**Documentation representative**              Torsten Malischewski  
 General Manager R&D

The devices bear the following marking:                      **CE**

**Bad Salzufflen**  
**22 July 2022**

G. Gödde  
 Managing director

09010134 • CE\_EN\_DE46\_LCD • Rev. ST4-A • 07/22

1 / 1



Fig. 20: CE\_EN\_DE46\_LCD

## 8.2 UKCA Declaration of Conformity



(Translation) UK  
CA

### UKCA Declaration of Conformity

For the product described as follows

**Product designation**                      **Digital differential pressure transmitter / switch with colour change LCD**

**Type designation**                         **DE46**

is hereby declared to comply with the essential requirements, specified in the following UK regulations:

<i>Statutory regulation No.</i>	<i>Description</i>
2016 No. 1091	<i>The Electromagnetic Compatibility Regulations 2016</i>
2021 No. 422	<i>The Restriction of the Use of Certain Hazardous Substances in Electrical and Electronic Equipment (Amendment) Regulations 2021</i>
2022 No. 1647	<i>The Hazardous Substances and Packaging (Legislative Functions and Amendment) (EU Exit) Regulations 2020</i>

The products have been tested according to the following standards.

#### Explosive atmospheres (ATEX):

#### Electromagnetic compatibility (EMC):

<i>BS EN 61326-1:2013-02-28</i>	<i>Electrical equipment for measurement, control and laboratory use. EMC requirements. General requirements</i>
<i>BS EN 61326-2-3:2013-02-28</i>	<i>Electrical equipment for measurement, control and laboratory use. EMC requirements. Particular requirements. Test configuration, operational conditions and performance criteria for transducers with integrated or remote signal conditioning.</i>

#### Restriction of Hazardous Substances (RoHS):

<i>BS EN IEC 63000:2018-12-10</i>	<i>Technical documentation for the assessment of electrical and electronic products with respect to the restriction of hazardous substances</i>
-----------------------------------	---

The sole responsibility for drawing up this declaration of conformity in relation to the fulfilment of the essential requirements and the preparation of the technical documentation lies with the manufacturer.

**Manufacturer**                                      **FISCHER Mess- und Regeltechnik GmbH**  
Bielefelder Str. 37a  
32107 Bad Salzufflen, Germany  
Tel. +49 (0)5222 974 0

The devices bear the following marking:



Bad Salzufflen  
22 July 2022

G. Gödde  
Managing director



Fig. 21: UKCA\_EN\_DE46\_LCD



### 8.3 EAC declaration



## ЕВРАЗИЙСКИЙ ЭКОНОМИЧЕСКИЙ СОЮЗ ДЕКЛАРАЦИЯ О СООТВЕТСТВИИ



**Заявитель** Общество с ограниченной ответственностью "МАТИС-М"

Место нахождения: Россия, Москва, 117261, улица Вавилова, дом 70, строение 3, Комната Правления, адрес места осуществления деятельности: Россия, Москва, 109029, Сибирский проезд, дом 2, строение 9, офис 58, основной государственный регистрационный номер: 1037739575125, номер телефона: +74957252304, адрес электронной почты: info@matis-m.ru

**в лице** Генерального директора Шарова Александра Анатольевича

**заявляет, что** Датчики дифференциального давления серии DE

**изготовитель** "FISCHER Mess- und Regeltechnik GmbH". Место нахождения и адрес места осуществления деятельности по изготовлению продукции: Bielefelder Straße 37a, D-32107 Bad Salzuflen, GLN отсутствует, координаты ГЛОНАСС: 52.056894, 8.725524, Германия.

Продукция изготовлена в соответствии с Директивой 2014/35/EU.

Код ТН ВЭД ЕАЭС 9026202000. Серийный выпуск

**соответствует требованиям**

Технического регламента Таможенного союза "О безопасности низковольтного оборудования" (ТР ТС 004/2011), Технического регламента Таможенного союза "Электромагнитная совместимость технических средств" (ТР ТС 020/2011)

**Декларация о соответствии принята на основании**

Протоколов испытаний № 0105-ИЛ23/2022, 0105-ИЛ23/2022 от 31.01.2022 года, выданных Испытательной лабораторией Общества с ограниченной ответственностью «ПромМашЭксперт», аттестат аккредитации РОСС RU.32001.04ИБФ1.ИЛ23, сроком действия до 02.02.2022 года.

Схема декларирования 1д

**Дополнительная информация**

Условия и сроки хранения стандартные при нормальных значениях климатических факторов внешней среды, срок службы (годности) указан в эксплуатационной документации. Договор на выполнение функций иностранного изготовителя № 2016-09-29/01 от 29.09.2016.

**Декларация о соответствии действительна с даты регистрации по 31.01.2027 включительно**

  
(подпись)

М. П.

Шаров Александр Анатольевич

(Ф.И.О. заявителя)

Регистрационный номер декларации о соответствии: ЕАЭС N RU Д-DE.РА01.В.52516/22

Дата регистрации декларации о соответствии: 01.02.2022

Fig. 22: EAC\_RU\_DE

## Notes

## Notes



**FISCHER Mess- und Regeltechnik GmbH**

Bielefelder Str. 37a  
D-32107 Bad Salzuflen

Tel. +49 5222 974-0

Fax +49 5222 7170

[www.fischermesstechnik.de](http://www.fischermesstechnik.de)  
[info@fischermesstechnik.de](mailto:info@fischermesstechnik.de)