



IEC 61508
SIL



DIN 4754



DNVGL.COM/AF



RoHS III
COMPLIANT



Operating Manual

DS21

Differential pressure measuring and switching device

Flow guard in heat transfer oil systems in compliance with DIN 4754-2
and hot water systems according to VdTÜV Information sheet "Flow 100"

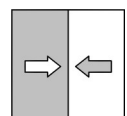
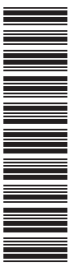

Masthead

Manufacturer:
FISCHER Mess- und Regeltechnik GmbH

Bielefelderstr. 37a
D-32107 Bad Salzuflen

Telephone: +49 5222 974 0
Telefax: +49 5222 7170

eMail: info@fischermesstechnik.de
web: www.fischermesstechnik.de

Technical editorial team:

Technical editor: R. Kleemann

All rights, also those to the translation, reserved. No part of this document may be reproduced or processed, duplicated or distributed using electronic systems or any other form (print, photocopy, microfilm or another process) without the written consent of the company FISCHER Mess- und Regeltechnik GmbH, Bad Salzuflen.

Reproduction for internal use is expressly allowed.

Brand names and procedures are used for information purposes only and do not take the respective patent situation into account. Great care was taken when compiling the texts and illustrations. nevertheless, errors cannot be ruled out. The company FISCHER Mess- und Regeltechnik GmbH will not accept any legal responsibility or liability for this.

Subject to technical amendments.



© FISCHER Mess- und Regeltechnik GmbH 2015

Version history

Rev. ST4-A	09/14	Version 1	(first edition)
Rev. ST4-B	06/15	Version 2	(Correction)
Rev. ST4-C	01/16	Version 3	Flow 100, DIN CERTCO 4754-2
Rev. ST4-D	06/16	Version 4	New EU directives
Rev. ST4-E	09/16	Version 5	DIN 19216 replaces VDE/VDI 3512 sheet 1
Rev. ST4-F	01/19	Version 6	Order codes optional information (SIL)
Rev. ST4-G	07/19	Version 7	DNV-GL Certificate updated
Rev. ST4-H	11/19	Version 8	GL becomes DNV-GL
Rev. ST4-I	04/20	Version 9	SIL Certificate updated
Rev. ST4-K	01/21	Version 10	DIN CERTCO Certificate updated
Rev. ST4-L	08/21	Version 11	Section 3.3.2 corrected
Rev. ST4-M	01/23	Version 12	Certificates updated
Rev. ST4-N	11/23	Version 13	Section 2.1 Printer guideline notice
Rev. ST4-O	01/25	Version 14	(applied standards, certificates and declarations of conformity updated)

Table of contents

1 Safety notes	5
1.1 General.....	5
1.2 Personnel Qualification	5
1.3 Risks due to Non-Observance of Safety Instructions.....	5
1.4 Safety Instructions for the Operating Company and the Operator	5
1.5 Unauthorised Modification	5
1.6 Inadmissible Modes of Operation	5
1.7 Safe working practices for maintenance and installation work.....	6
1.8 Pictogram explanation.....	6
2 Product and functional description	7
2.1 Use as intended	7
2.2 Equipment versions.....	8
2.3 Function diagram.....	10
2.4 Design and mode of operation	10
2.5 Market access	10
3 Installation and assembly	11
3.1 General.....	11
3.2 Assembly.....	11
3.3 Process connection	11
3.4 Electrical connections.....	12
4 Commissioning	14
4.1 General.....	14
4.2 Display and control elements	14
4.3 Lead seal.....	15
4.4 Zero point correction	15
4.5 Switch point setting	15
4.6 Function test.....	15
5 Maintenance	17
5.1 Wartung (maintenance).....	17
5.2 Transport.....	17
5.3 Service	17
5.4 Accessories	17
5.5 Disposal.....	18

6 Technical data	19
6.1 Input variables	19
6.2 Output parameters	19
6.3 Measured Value Display	19
6.4 Electrical connection	20
6.5 Application conditions.....	21
6.6 Construction design.....	21
6.7 Dimensional drawings	22
7 Order Codes	27
8 Attachments	29

1 Safety notes

1.1 General

This operating manual contains basic instructions for the installation, operation and maintenance of the device that must be followed without fail. It must be read by the installer, the operator and the responsible specialist personnel before installing and commissioning the device.

This operating manual is an integral part of the product and therefore needs to be kept close to the instrument in a place that is accessible at all times to the responsible personnel.

The following sections, in particular instructions about the assembly, commissioning and maintenance, contain important information, non-observance of which could pose a threat to humans, animals, the environment and property.

The instrument described in these operating instructions is designed and manufactured in line with the state of the art and good engineering practice.

1.2 Personnel Qualification

The instrument may only be installed and commissioned by specialized personnel familiar with the installation, commissioning and operation of this product.

Specialized personnel are persons who can assess the work they have been assigned and recognize potential dangers by virtue of their specialized training, their skills and experience and their knowledge of the pertinent standards.

1.3 Risks due to Non-Observance of Safety Instructions

Non-observance of these safety instructions, the intended use of the device or the limit values given in the technical specifications can be hazardous or cause harm to persons, the environment or the plant itself.

The supplier of the equipment will not be liable for damage claims if this should happen.

1.4 Safety Instructions for the Operating Company and the Operator

The safety instructions governing correct operation of the instrument must be observed. The operating company must make them available to the installation, maintenance, inspection and operating personnel.

Dangers arising from electrical components, energy discharged by the medium, escaping medium and incorrect installation of the device must be eliminated. See the information in the applicable national and international regulations.

Please observe the information about certification and approvals in the Technical Data section.

1.5 Unauthorised Modification

Modifications of or other technical alterations to the instrument by the customer are not permitted. This also applies to replacement parts. Only the manufacturer is authorised to make any modifications or changes.

1.6 Inadmissible Modes of Operation

The operational safety of this instrument can only be guaranteed if it is used as intended. The instrument model must be suitable for the medium used in the system. The limit values given in the technical data may not be exceeded.

The manufacturer is not liable for damage resulting from improper or incorrect use.

1.7 Safe working practices for maintenance and installation work

The safety instructions given in this operating manual, any nationally applicable regulations on accident prevention and any of the operating company's internal work, operating and safety guidelines must be observed.

The operating company is responsible for ensuring that all required maintenance, inspection and installation work is carried out by qualified specialized personnel.

1.8 Pictogram explanation



DANGER

Type and source of danger

This indicates a **direct** dangerous situation that could lead to death or **serious injury** (highest danger level).

1. Avoid danger by observing the valid safety regulations.



WARNING

Type and source of danger

This indicates a **potentially** dangerous situation that could lead to death or **serious injury** (medium danger level).

1. Avoid danger by observing the valid safety regulations.



CAUTION

Type and source of danger

This indicates a **potentially** dangerous situation that could lead to slight or serious injury, damage or **environmental pollution** (low danger level).

1. Avoid danger by observing the valid safety regulations.



NOTICE

Note / advice

This indicates useful information of advice for efficient and smooth operation.

2 Product and functional description

2.1 Use as intended

The unit is exclusively designed for the purpose defined by the manufacturer in the data sheet or operating instructions.

Differential pressure measuring and switching device

The DS21 is a measuring and switch unit for measuring differential pressure under difficult measuring conditions such as: pressure surges, vibrations, frequent switching and high demands on the switching output. Please contact the manufacturer before using this unit with dirty or aggressive media because the unit needs to be adapted in terms of the parts that come into contact with the media.

NOTICE! With regard to the Pressure Equipment Directive, the device is designed for a static load of up to 25 bar and a media temperature of up to 85 °C.

Flow assurance

The units in this series are used as flow guards in heat transfer oil systems in compliance with DIN 4754-2 and hot water systems in compliance with VdTÜV information sheet 'Flow 100'. The flow guards comprise a differential pressure transducer, e.g. a measuring orifice, the differential pressure measuring and switch unit and shut-off fittings. The respective installation instructions must be observed for this application case. All units of the series DS21 satisfy these requirements.



NOTICE

The type tests in compliance with DIN 4754-2 and VdTÜV information sheet "Flow 100" only apply in conjunction with a differential pressure transducer, not for a differential pressure measuring and switching device alone.

The successful type test of the series DS21 was confirmed by means of the following test symbols:

- for flow guards in compliance with DIN 4754-2 :
DIN CERTCO registration number 10S001
- according to VdTÜV Information sheet "Flow 100" :
Part code TÜV . SW/SB . 15 – 020

Use in safety-related systems (SIL)

The unit can be used in safety-related systems.

For use in safety-related systems according to 'Functional Safety' (SIL), the correct function of the safety function must be proven. The necessary key figures, safety instructions, assembly and maintenance instructions can be found in the Safety Manual (SHB).

The safety manual is available for download at www.fischermesstechnik.de.



IEC 61508 SIL

2.2 Equipment versions

The DS21 can be supplied with the following different pressure chambers:

- Aluminium
- Stainless steel 1.4305

The aluminium pressure chambers can also be supplied with a HART COAT® coating. The following shows the various unit versions. On the left-hand side are casings with hoods (IP 55) and on the right-hand side casings with bayonet rings (IP 65).



NOTICE

Installation of front panel

Please note that the switch points of devices with bayonet rings need to be set before mounting the front control panel. When installed, the unit can no longer be opened.

Please see the order code [▶ 27] for the process connection options.

2.2.1 Pressure chamber in aluminium

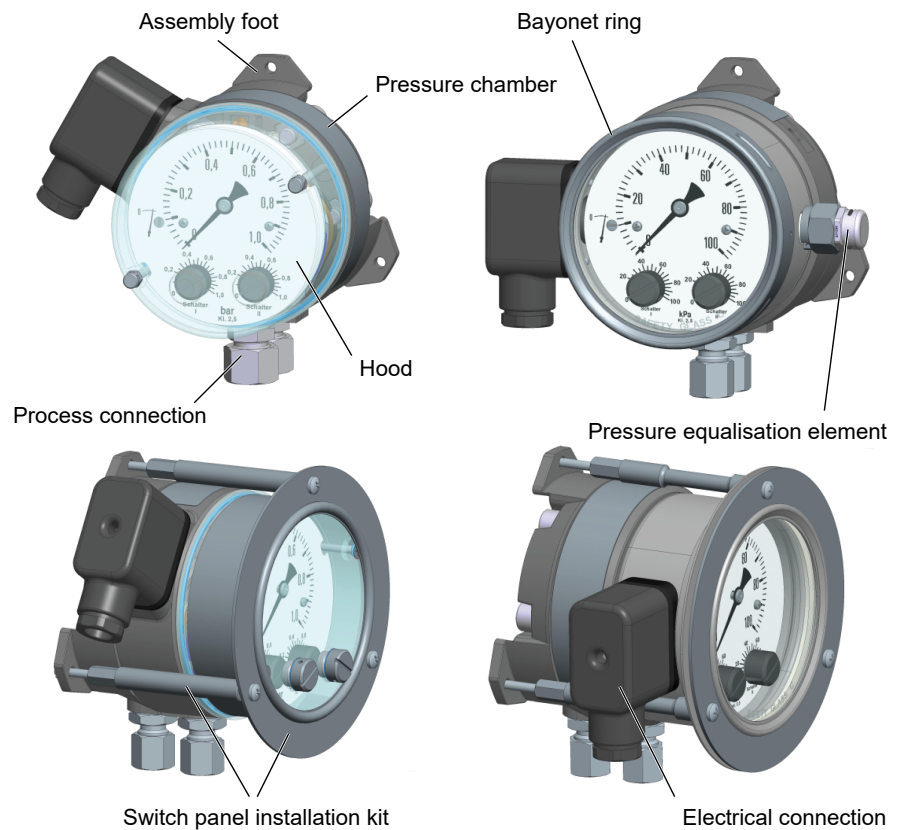

Fig. 1: DS21_Pressure chamber in aluminium [Standard]

2.2.2 Pressure chamber in stainless steel

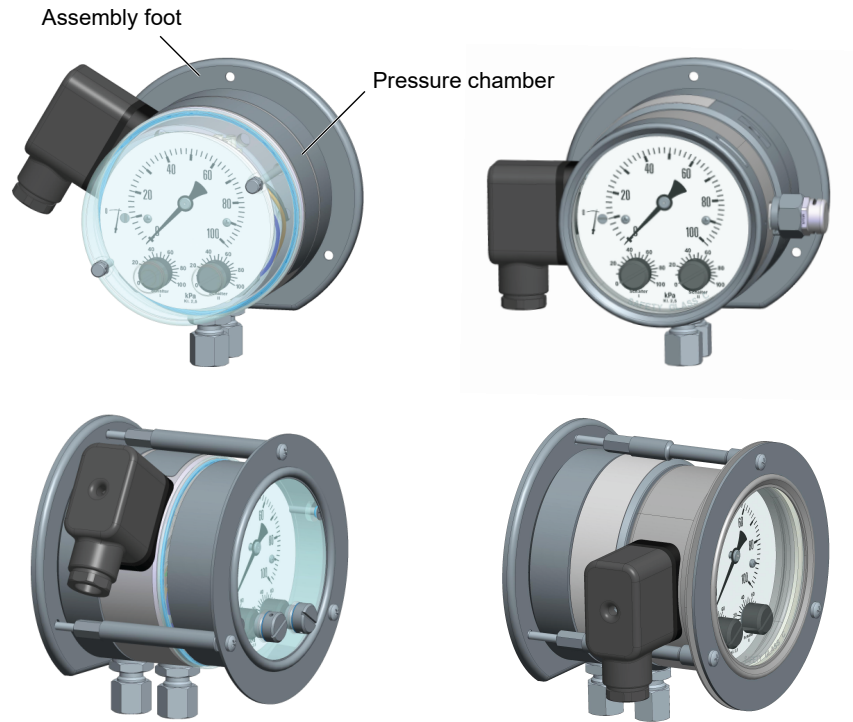

Fig. 2: DS21_Pressure chamber in stainless steel [Standard]

2.2.3 Electro connection variants

All pressure chamber types are available optionally with a permanently wired number cable, a cable connection socket or a cable connector. The cable connector has the same dimensions as the cable socket.

DNV-GL models are an exception. These are only supplied with a cable socket including a 3 m long connection cable. The associated wiring diagrams are shown on the type plate and in the section 'Installation and assembly'.

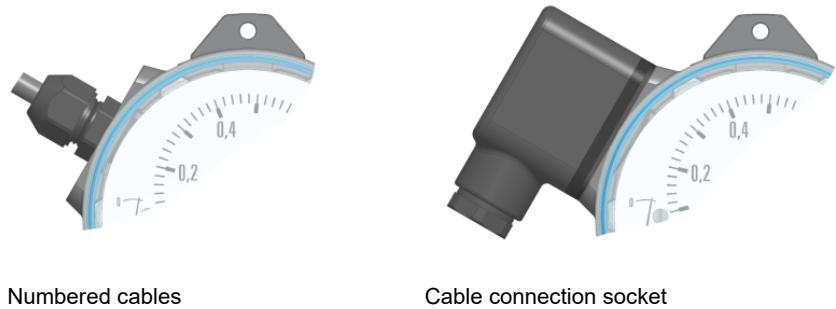

Fig. 3: DS21_EL-connection variants [Standard]

2.3 Function diagram

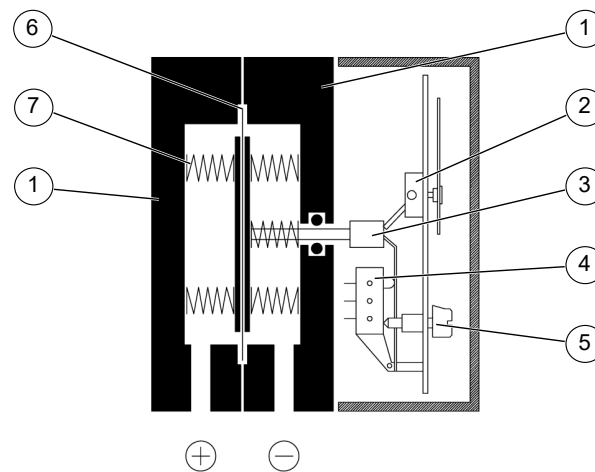

Fig. 4: DS21 Function diagram [Standard]

1	Pressure chamber	2	Motion train
3	Tappet	4	Micro-switch
5	Switch point setting	6	Measuring diaphragm
7	Measuring springs		

2.4 Design and mode of operation

The basis for this measurement and switch unit is a sturdy non-sensitive diaphragm measuring unit that is suitable for measuring differential pressure, and over and under-pressure. The unit uses the same measuring principle for all three measuring applications.

In the idle position, the spring forces are equalised on both sides of the measuring diaphragm. The pressure that is to be measured or the differential pressure creates a one-sided force on the measuring diaphragm that moves the diaphragm system against the measuring range springs until the spring forces are equalised. In the case of overload, the measuring diaphragm is supported by metallic contact surfaces.

A central tappet transfers the movement of the diaphragm system onto the display mechanism and, at the same time, onto the actuation elements of the micro-switches. The switch points are set via the setting screws and refernece value scale.

2.5 Market access

The approval or type examination by a notified body is valid throughout the EU. The acceptance of the certificates issued for export to third countries must be checked in each individual case.

UK market (UKCA)

With the 'BREXIT', EU testing institutes lose their validity as notified bodies in the UK. The certificates issued in the EU will subsequently no longer be recognised.

3 Installation and assembly

3.1 General

The instrument may only be installed and commissioned by specialized personnel familiar with the installation, commissioning and operation of this product.

Specialized personnel are persons who can assess the work they have been assigned and recognize potential dangers by virtue of their specialized training, their skills and experience and their knowledge of the pertinent standards.

3.2 Assembly

The standard unit is designed for wall mounting. In the case of units with an aluminium pressure chamber, there are three mounting feet. Units with stainless steel pressure chambers are mounted using the rear attachment plate that also acts as a mounting foot.

A control panel installation set can be ordered for each unit that allowed installation on the front of the unit.

The unit is set for vertical installation ex-works. Only this installation position is allowed. To ensure safety during installation and maintenance, we recommend installing a suitable shut-off valve on the system.

3.3 Process connection

- By authorized and qualified specialized personnel only.
- The pipes need to be depressurized when the instrument is being connected.
- Appropriate steps must be taken to protect the device from pressure surges.
- Check that the device is suitable for the medium being measured.
- Maximum pressures must be observed (cf. Tech. data)

The differential pressure connections are marked with (+) and (-) symbols on the device. The differential pressure connection lines must be mounted according to these symbols.

- (+) Higher pressure
- (-) Lower pressure

The differential pressure lines must be installed at an inclination so that when fluids are measured no air pockets are created or when measuring gases, no water pockets are created. If the required inclination is not reached, water or air filters must be installed at suitable places.

The differential pressure lines must be kept as short as possible and installed without any tight bends to avoid delays.

In the case of fluid measuring media, the differential pressure lines must be vented because different fluid columns in the lines will distort the measurements.

If water is used as a measuring medium, the unit must be protected against frost.

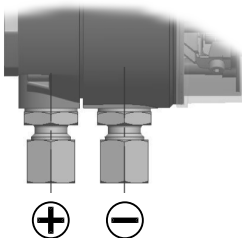

Fig. 5: Differential pressure connection

3.3.1 Installation regulations for flow guards in heat transfer units in compliance with DIN 4754-2

In the case of differential pressure transducers in compliance with DIN 1952/VDI 2014, the measurement must be set up in compliance with DIN 4754-2 Sec. 4.3.4.

Shut-off valves in differential pressure lines may only be activated with tools. Threaded screw connections in these lines must be designed so that they remain tight without any sealing agent, or the connection must be welded or hard-soldered.

The clear diameter and length of differential pressure lines must be dimensioned so that when the line is cold (approx. 20 °C), the response time of the unit is no longer than 5 sec.

Differential pressure lines must be made of metal. Their clear width may not undercut 4 mm and the stretched length must be at least 500 mm. If arranged with block valves, the differential pressure line between the valve block and differential pressure transducer must be at least 500 mm.

Locking and unlocking conditions must be ensured during installation via the following electrical lines.

3.3.2 Installation regulations for flow limiters in steam boilers and hot water systems

Differential pressure transducers in compliance with DIN 1952/VDI 2041, Itabar or Annubar probes must be used as measuring elements. The measurement must be taken in compliance with DIN 19216 Sec. 6.

Shut-off valves in differential pressure lines may only be activated with tools. Threaded screw connections in these lines must be designed so that they remain tight without any sealing agent, or the connection must be welded or hard-soldered.

The differential pressure lines must be made of metal and have a clear width of at least 8 mm. The stretched length of the differential pressure lines must be at least 500 mm.

3.4 Electrical connections

- By authorized and qualified specialized personnel only.
- When connecting the unit, the national and international electro-technical regulations must be observed.
- Disconnect the system from the mains, before electrically connecting the device.
- Install the consumer-adapted fuses.
- Do not connect the connector if strained.

No	Contact	Switch	
1	Make contact	NO	
2	Break contact	NC	
3	Joint	COM	
4	Joint	COM	
5	Make contact	NO	
6	Break contact	NC	
⊕	Ground connection		

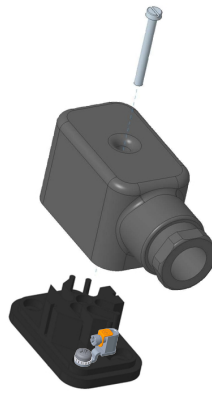

Fig. 6: Cable socket

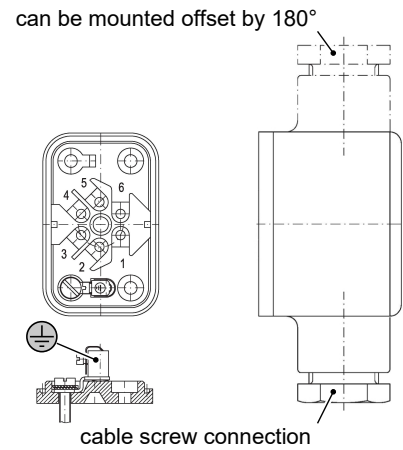
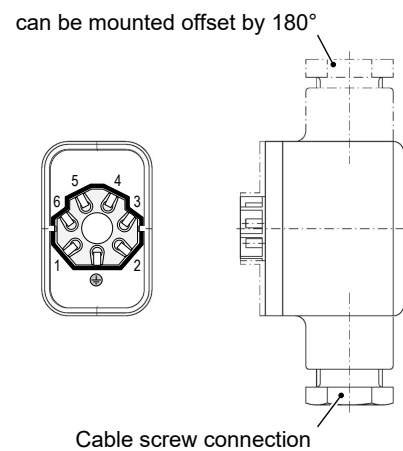

Fig. 7: Cable plug



For models with numbered cables, the cable numbers correspond with the presented terminal numbers.

DNV-GL version

In models with one switch, a cable **(0.6/1KV 4Gx1.5)** with the following color code is connected:

Ter- minal	Wire ID
1	grey
2	brown
3	black
⊕	green/yellow

In models with two switches, a cable **(0.6/1KV 7Gx1.5)** with numbers for identifying the wires must be connected. The numbers of the cable correspond to the terminal numbers of the cable socket.

4 Commissioning

4.1 General

The instrument may only be installed and commissioned by specialized personnel familiar with the installation, commissioning and operation of this product.

Specialized personnel are persons who can assess the work they have been assigned and recognize potential dangers by virtue of their specialized training, their skills and experience and their knowledge of the pertinent standards.

A prerequisite for commissioning is correct installation of all electrical supply lines and the differential pressure lines. All connections are arranged so that there are no mechanical forces acting on the device.



⚠ CAUTION

Leak test

The differential pressure lines need to be checked for leaks before commissioning.

4.2 Display and control elements

The illustration shows an example because the measurement scale and therefore also the reference value scale depend on the respective measuring range. The position and form of the control elements are at least similar to the illustration.

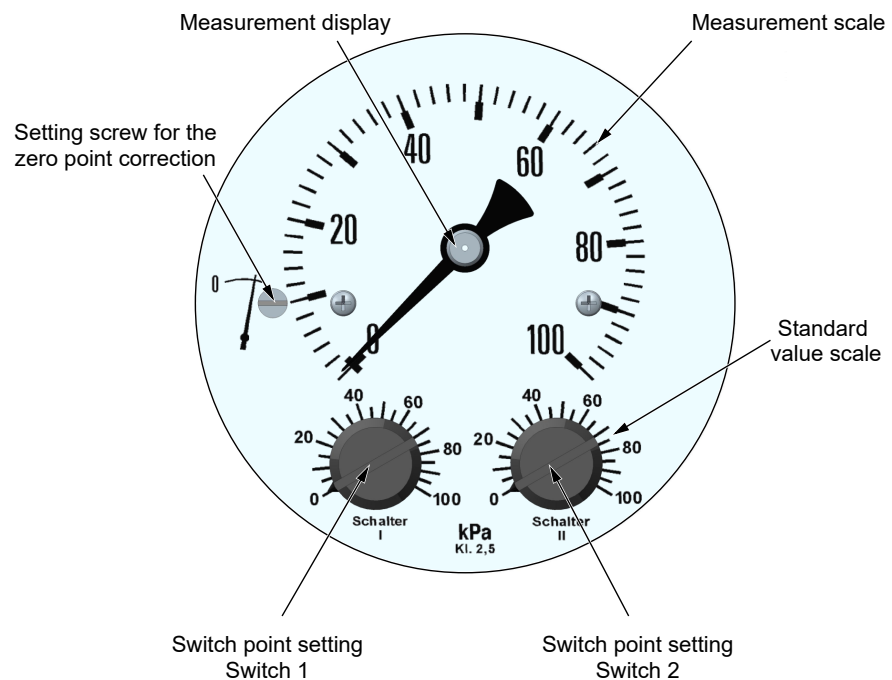

Fig. 8: Control elements [DS21]

4.3 Lead seal

It is possible to secure the unit against removal and adjustment of the switch points by means of a lead seal. This seal may not be removed. The device can be sealed on site or ex-works. In the latter case, the device is supplied with a pre-setting. After this, it is no longer possible to adjust the switch point setting or correct the zero-point.

4.4 Zero point correction

1. Load the pressure chamber with the existing static system pressure.
2. Open the unit either by removing the hood or the bayonet ring and the front disk. Use a wrench to mount or remove the bayonet ring to prevent damage to the casing.
3. Set the measurement display with the setting screw for correcting the zero-point to the zero-point of the measurement scale.
4. Close the unit.

4.5 Switch point setting

1. Open the unit either by removing the hood or the bayonet ring and the front disk. Use a wrench to mount or remove the bayonet ring to prevent damage to the casing.
2. Use a screwdriver to set the required switch points in compliance with the markings on the standard value scale.
3. Close the unit.



NOTICE

Setting accuracy

The achievable setting accuracy with the standard value scale is $\pm 5\%$.

A higher level of precision can only be achieved using suitable units such as test manometers, ohmmeters etc. Optionally, these devices can be pre-installed ex-works.

4.6 Function test

Open the unit either by removing the hood or the bayonet ring and the front disk.

If the unit has two switch points, the stated test steps must be carried out for both switches.

After the test, the switch points need to be reset (see above).



NOTICE

Lead seal

It is possible to secure the bayonet ring or the hood against removal by means of a lead seal. This seal may not be removed. A function test can only be carried out in this case by changing the operating pressure (see below).

4.6.1 Checking the switch points in a depressurized state

No measurement is shown and the measurement display point to zero.

Turn the switch point setting button toward the zero-point until the micro-switch is activated.

4.6.2 Checking the switch points when the system is operational

A measurement is shown. If despite operational pressure, no measurement is shown, you can generate a differential pressure by blocking the differential pressure line on one side.

Turn the switch point setting button toward the measurement until the micro-switch is activated.

4.6.3 Checking the switch points by changing the operational pressure

If the unit is sealed or the switch point setting cannot be changed for any other reason, you can carry out a function test by changing the operational pressure. Set the differential pressure so that the micro-switch(es) are activated.

5 Maintenance

5.1 Wartung (maintenance)

The unit is maintenance-free apart from regular cleaning of the surface of the casing.



WARNING

Dust deposits

The casing of the unit must be cleaned regularly with a damp cloth to prevent heat accumulation, as this can lead to the surface overstepping the maximum allowed temperature (T70 °C). The cleaning frequency depends on the amount of dust in the location.

To ensure reliable operation and a long service life, we recommend carrying out the following test on a regular basis:

- Check the reading.
- Checking the switch function in connection with the downstream components.
- Checking the differential pressure lines for leaks.
- Checking the electrical connections (terminal connection of the cable).

The precise test cycles and operating and ambient conditions need to be adjusted. If several components of the unit interact, all operating instructions of the other units also need to be observed.

5.2 Transport

The measuring device must be protected against impacts. It should be transported in the original packaging or a suitable transport container.

5.3 Service

All defective or faulty devices should be sent directly to our repair department. Please coordinate all shipments with our sales department.



WARNING

Process media residues

Process media residues in and on dismantled devices can be a hazard to people, animals and the environment. Take adequate preventive measures. If required, the devices must be cleaned thoroughly.

Return the device in the original packaging or a suitable transport container.

5.4 Accessories

Recommended shut-off fitting

- DZ23 Three-spindle equalisation and shut-off valve
Art.No. DZ2300H ###
For casing material and pressure connection, see data sheet
- DZ23 Four-spindle equalisation and shut-off valve with venting valve
Art.No. DZ2400H ###
For casing material and pressure connection, see data sheet

5.5 Disposal

Please help to protect the environment by always disposing of the work pieces and packaging materials in compliance with the valid national waste and recycling guidelines or reuse them.

6 Technical data

Please also observe the order code here.

6.1 Input variables

Measuring variable

Differential, over and under-pressure for gaseous and fluid media.

Measurement range

Measurement range	Allowed static operating pressure
0 ... 250 mbar	6 bar
0 ... 400 mbar	6 bar
0 ... 0.6 bar	10 bar
0 ... 1 bar	16 bar
0...1.6 bar	16 bar
0...2.5 bar	16 bar
0 ... 4 bar	16 bar
0 ... 6 bar	16 bar

Rated pressure of the measuring system

25 bar

Max. pressure load

Over-pressure-proof on one side up to rated pressure of the measuring system, (+) and (-) sides, under-pressure-proof

6.2 Output parameters

Switching outputs

1 or 2 micro-switches with 1-pin changeover contact.

Switch point setting

After opening the casing using the setting screw and reference value scale. Smallest settable value approx. 5% of the end value of the measuring range.

Reproducibility

The reproducibility of the switch-point setting corresponds to the measuring precision.

Switch hysteresis

approx. 2.5% of the upper range value

Load data/contact

		AC	DC
Max. switching voltage	U_{\max}	250V	30V
Max. switching current	I_{\max}	5A	0.4A
max. switching output	P_{\max}	250 VA	10 W

6.3 Measured Value Display

Anzeige

Indicator with measurement scale

Measurement accuracy

$\pm 2.5\%$ of the upper range value

6.4 Electrical connection

- Cable socket
screw terminal up to 1.5 mm² with wire protection
Contact material Ms gold-flashed
Cable screw connection M20 x 1.5
- Cable connector
screw terminal up to 1.5 mm² with wire protection
Contact material Ms nickel-plated
Cable screw connection M20 x 1.5
- Number cable
4 x 0.75 mm² YSLY-JZ
strand end with clip, wire ID 1,2,3, green/yellow

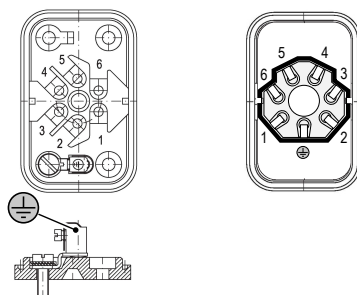

Fig. 9: Cable socket / plug

No	Contact	Switch	
1	Make contact	NO	
2	Break contact	NC	
3	Joint	COM	
4	Joint	COM	
5	Make contact	NO	
6	Break contact	NC	
⊕	Ground connection		

GL version

In models with one switch, a cable (**0.6/1KV 4Gx1.5**) with the following color code is connected:

Ter- minal	Wire ID
1	grey
2	brown
3	black
⊕	green/yellow

In models with two switches, a cable (**0.6/1KV 7Gx1.5**) with numbers for identifying the wires must be connected. The numbers of the cable correspond to the terminal numbers of the cable socket.

6.5 Application conditions

Ambient conditions	Allowed ambient temperatures	-10 °C ... +70 °C
	Allowed temperature of the medium	-10 °C ... +85 °C ^{*)}
	Enclosure protection class (depending on model)	IP 55 or IP 65 in compliance with DIN EN 60529

^{*)} The temperature in the unit may not exceed +70 °C.

EC Declaration of conformity	Low-Voltage Directive	2014/35/EU
	Pressurised Vessel Directive	2014/68/EU
	RoHS Directive	2011/65/EU (EU) 2015/863

Certificates	Type testing (Module B)	0045/202/1403/Z/01262/22/D/001(00)
	Quality assurance system (Module D)	0045/202/1404/Z/00289/21/D/001(01)
	EAC Declaration	EAĐC N RU Д-DE.PA01.B43065/22
	DIN CERTCO	10S001
	VdTÜV	TÜV.SW/SB.20-020
	DNV GL	TAA00002BW
	SIL 2 ^{**)}	44 799 13759902

^{**)} Only for devices with the order code for SIL (optional information).

6.6 Construction design

Process connection	Inner thread G $\frac{1}{4}$
	Cutting ring screw connection in steel for 6, 8, 10, 12 mm pipe
	Cutting ring screw connection in stainless steel 1.4571 for 6, 8, 10, 12 mm pipe
Measuring system	Pressure spring measuring diaphragm system
Weight	Pressure chamber in aluminium: approx. 1.2 kg Pressure chamber in CrNi steel: approx. 3.5 kg

6.6.1 Materials

Pressure chamber	Aluminium Gk-ALSi10Mg, painted black
	Aluminium Gk-ALSi10MG with HART-COAT [®] Surface protection
	CrNi steel 1.4305
Measuring diaphragm	Fabric-reinforced VITON [®]
Gaskets	VITON [®]
Inner parts in contact with the medium	CrNi-steel 1.4310, 1.4305
Hood	Polycarbonate (PC) Makrolon [®]
Bayonet ring	CrNi-Steel 1.4305
Front pane	Safety laminated glass

6.6.2 Assembly

Wall mounting
Mounting the control panel

6.7 Dimensional drawings

(All dimensions in mm unless otherwise stated)

6.7.1 Pressure chamber in aluminium

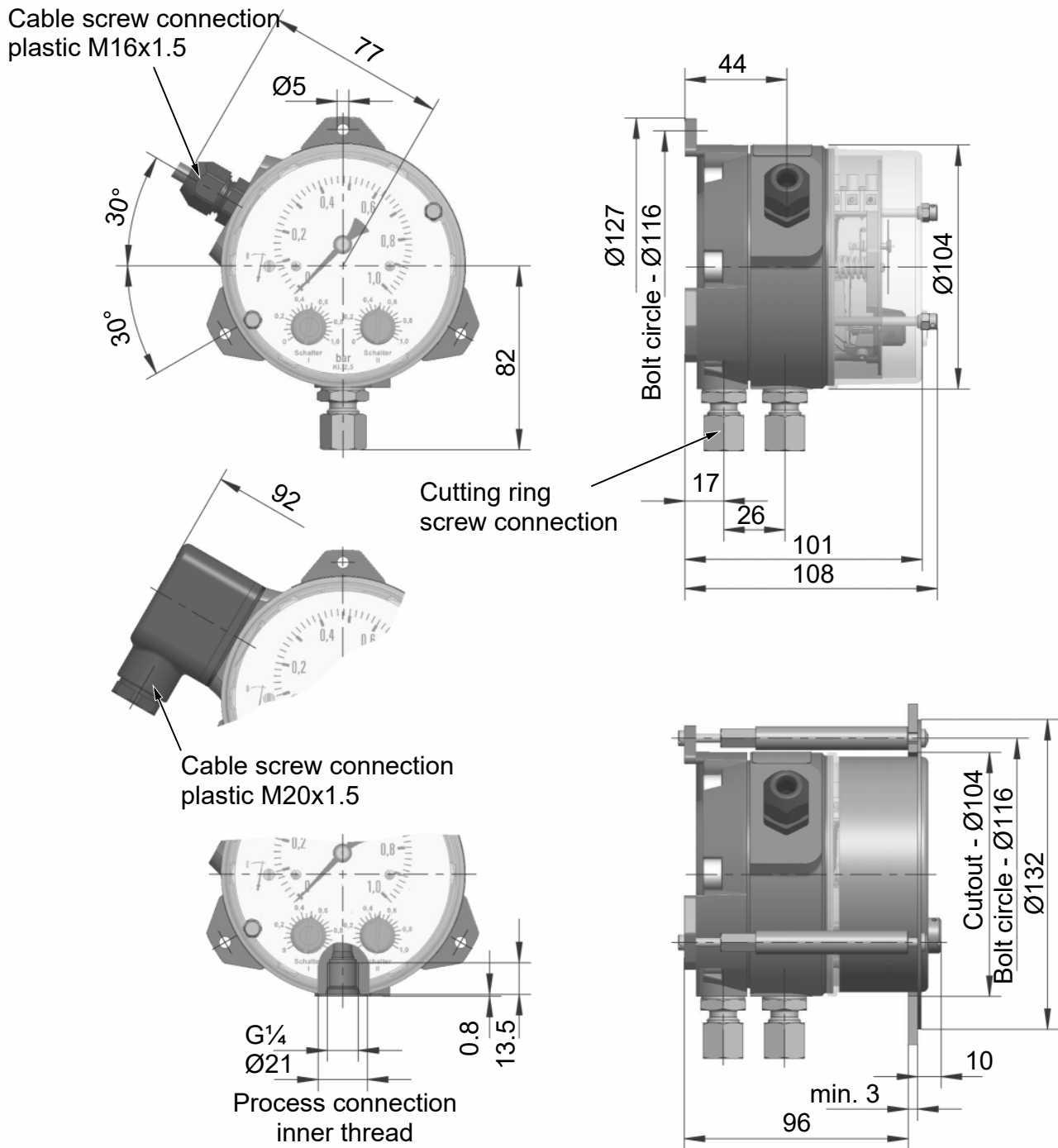

Fig. 10: Pressure chamber in aluminium (IP55)

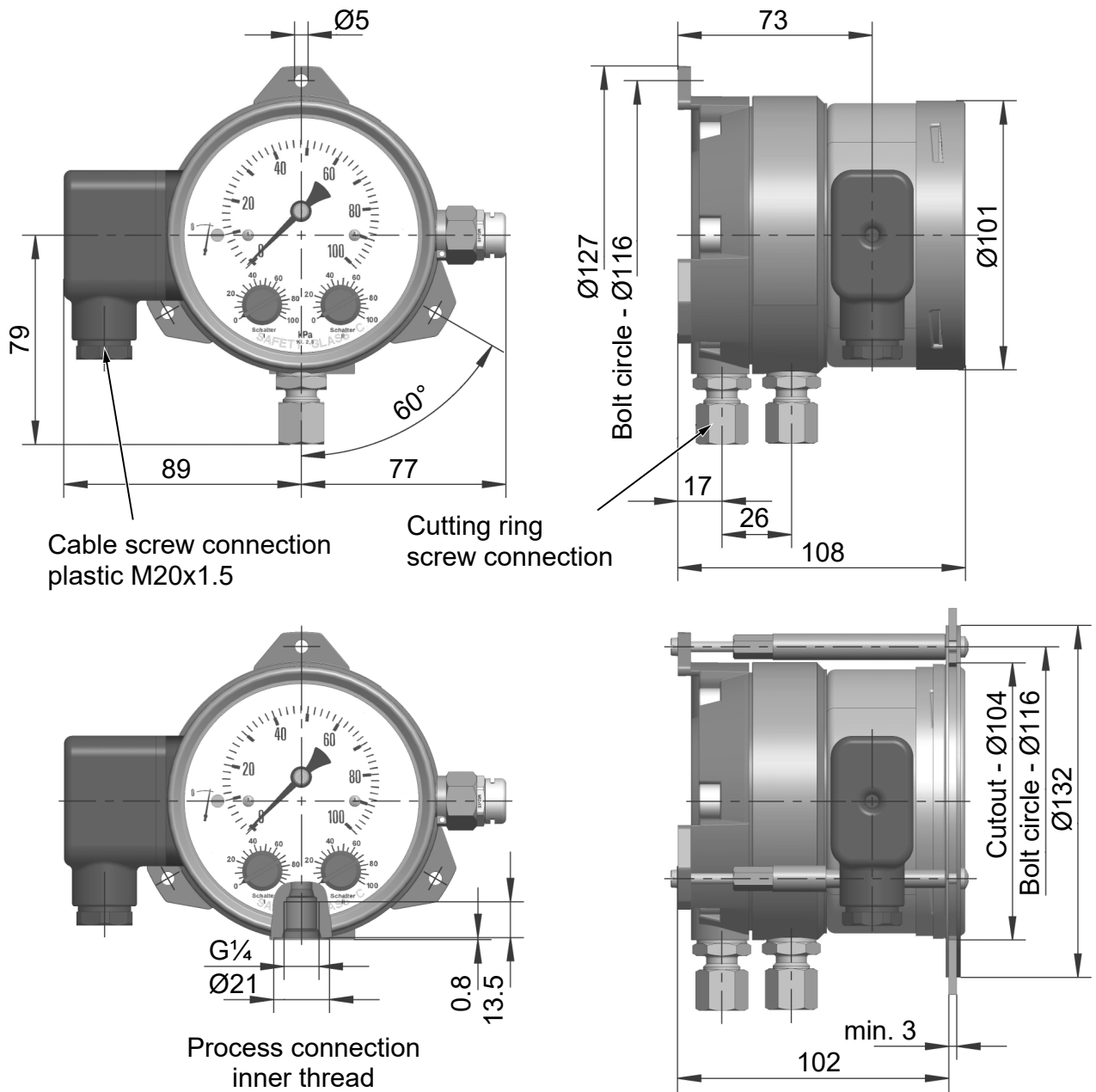

Fig. 11: Pressure chamber in aluminium (IP65)

6.7.2 Pressure chamber in stainless steel

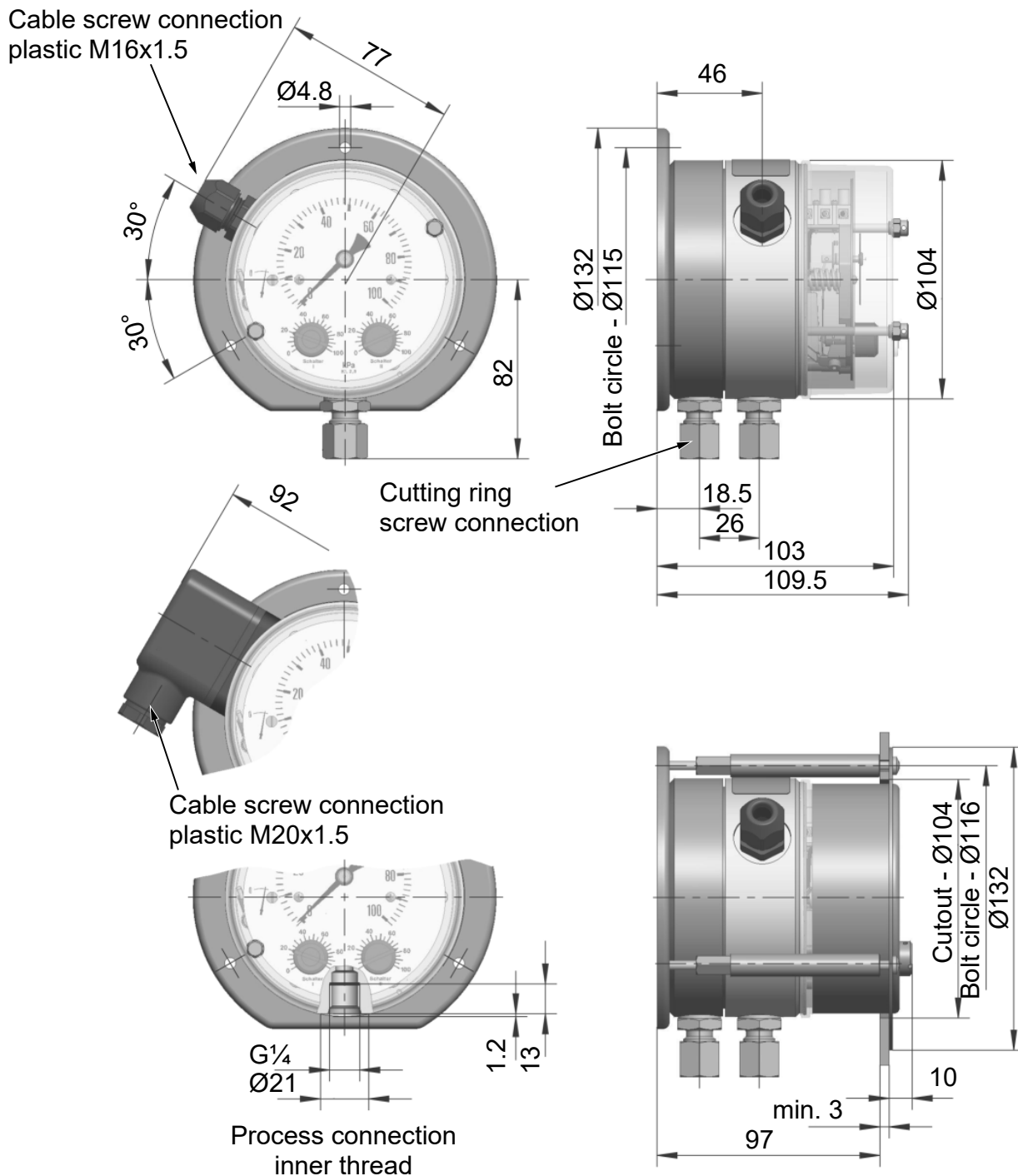

Fig. 12: Pressure chamber in VA (IP55)

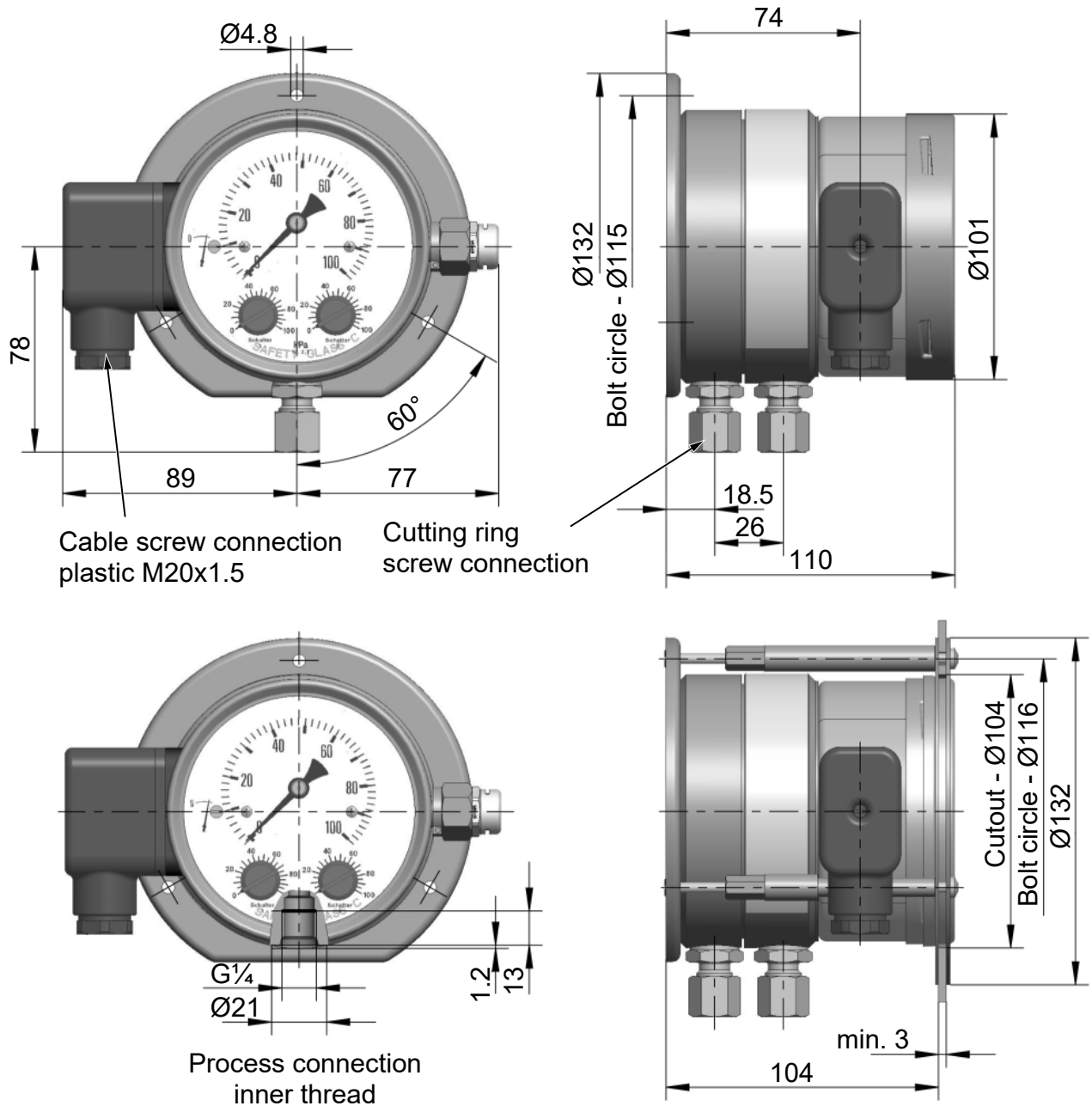

Fig. 13: Pressure chamber in VA (IP65)

6.7.3 Installation of front panel

The cutout required to mount the front control panel is the same for all models.

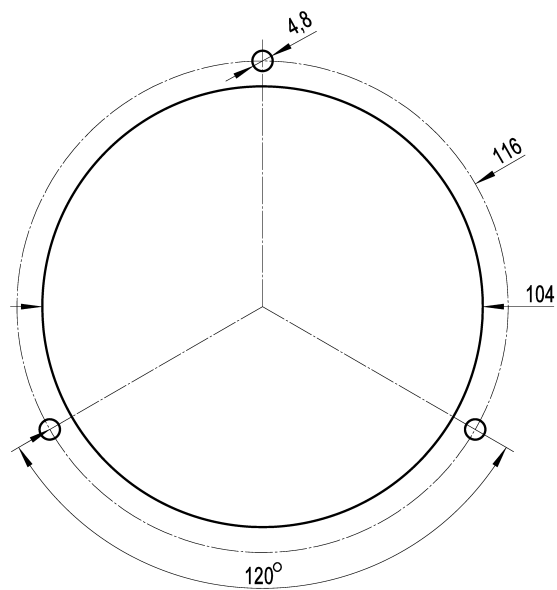
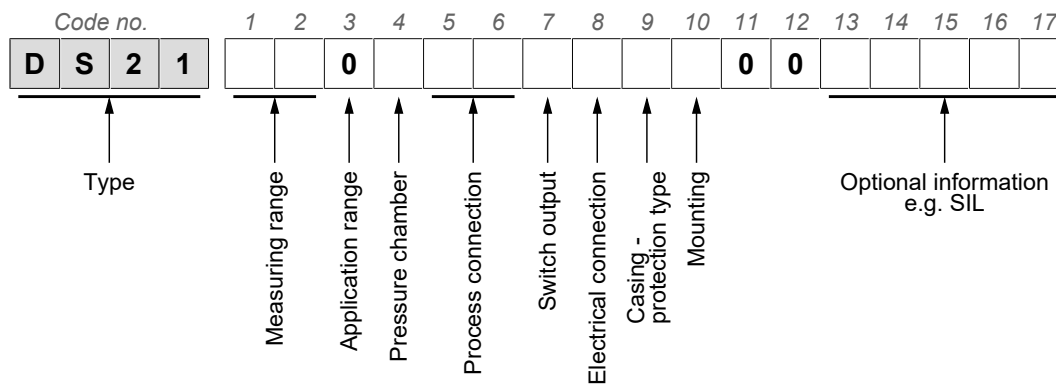

Fig. 14: Front panel cutout

7 Order Codes



Measuring range

[1.2]	← Code no.	Allowed static pressure
82	0 ... 250 mbar	6 bar
83	0 ... 400 mbar	6 bar
01	0 ... 0.6 bar	10 bar
02	0 ... 1 bar	16 bar
03	0 ... 1.6 bar	16 bar
04	0 ... 2.5 bar	16 bar
05	0 ... 4 bar	16 bar
06	0 ... 6 bar	16 bar

Application scope

[3]	← Code no.
0	Thermal oil DIN 4754-2 / Hot water Flow 100

Pressure chamber

[4]	← ? Code no.
A	Aluminium
D	Aluminium with HART COAT® coating
W	Stainless steel 1.4305

Process connection

[5.6]	← Code no.
01	Inner thread G 1/4
Cutting ring screw connections made of steel	
20	for 6 mm tube
21	for 8 mm tube
22	for 10 mm tube
23	for 12 mm tube
Cutting ring screw connections made of stainless steel 1.4571	
24	for 6 mm tube
25	for 8 mm tube
26	for 10 mm tube
27	for 12 mm tube

Switch output

[7]	← Code no.
A	1 micro-switch (can be configured)
B	2 micro-switch (can be configured)

Electrical connection	[8]	← Code no.
		Numbered cable, permanently wired
	1	1 m long
	2	2.5 m long
	5	5 m long
	K	Cable connection socket
	Z	DNV-GL version with 3 m connection cable
	W	Cable plug
Casing protection class	[9]	← Code no.
	0	IP55
	P	IP 65 (only with cable socket or cable connector)
Assembly	[10]	← Code no.
	T	Front panel mounting
	W	Wall mounting
Optional information	[13-17]	← Code no.
	#####	Code for special models e.g. SIL The code is generated as agreed with our sales team.

8 Attachments

8.1 EU Declaration of Conformity



(Translation) **CE**

EU Declaration of Conformity

For the product described as follows

Product designation **Differential pressure measuring and switching device**

Type designation **DS21**

it is hereby declared that it corresponds with the basic requirements specified in the following designated directives:

2014/35/EU	Low Voltage Directive
2014/68/EU	Pressure Equipment Directive
2011/65/EU	RoHS Directive
(EU) 2015/863	Delegated Directive amending Annex II to Directive 2011/65/EU

The products were tested in compliance with the following standards.

Low Voltage Directive (LVD)

DIN EN 61010-1:2020-03 EN 61010-1:2010 + A1:2019 + A1:2019/ AC:2019	Safety requirements for electrical equipment for measurement, control, and laboratory use - Part 1: General requirements
--	--

Pressure Equipment Directive (PED)

DIN EN 837-1:1997-02 EN 837-1:1996	Pressure gauges - Part 1: Bourdon tube pressure gauges; dimensions, metrology, requirements and testing
DIN EN 12516-2:2022-08 EN 12516-2:2014+A1:2021	Industrial valves - Shell design strength - Part 2: Calculation method for steel valve shells
DIN EN 12516-4:2018-11 EN 12516-4:2014+A1:2018	Industrial valves - Shell design strength - Part 4: Calculation method for valve shells manufactured in metallic materials other than steel

Pressure accessory category IV

The notified body for QA surveillance

TÜV NORD SYSTEMS GmbH & Co. KG
NB 0045

has issued the following certificates in accordance with Directive 2014/68/EU:

0045/202/1403/Z/01262/22/D/001(00)	EU type-examination certificate (type) - module B
---	---

RoHS-Richtlinie (RoHS3)

DIN EN IEC 63000:2019-05 EN IEC 63000:2018	Technical documentation for the assessment of electrical and electronic products with respect to the restriction of hazardous substances
--	--

Further applied technical specifications (not published in the Official Journal of the European Union):

AD2000 rules and regulations 2023	Regulations for pressure equipment, pressure vessels, steam boilers, pipework and plant engineering. Based on the European Pressure Equipment Directive (PED)
DIN 4754-2:2015-03 Vd-TÜV Leaflet	Heat transfer installations working with organic heat transfer fluids - Part 2: Draught diverter Flow 100
DIN EN 12952-11:2007-09 EN 12952-11:2007	Water-tube boilers and auxiliary installations - Part 11: Requirements for limiting devices of the boiler and accessories
DIN EN 12953-9:2007-09 EN 12953-9:2007	Shell boilers - Part 9: Requirements for limiting devices of the boiler and accessories
DIN EN 61508:2011 EN 61508:2010	Functional safety of electrical/electronic/programmable electronic safety-related systems - Parts 1-7



The product has been subjected to the conformity assessment procedures "Internal production control" (Module A) and

- a "type examination" (module B) in accordance with the Pressure Equipment Directive
- and "Conformity to type on the basis of quality assurance in relation to the production process" (Module D/D1).

The manufacturer is responsible for issuing this declaration of conformity with regard to the fulfilment of the essential requirements and the preparation of the technical documentation.

Manufacturer**FISCHER Mess- und Regeltechnik GmbH**

Bielefelder Str. 37a
32107 Bad Salzufen, Germany
Tel. +49 (0)5222 974 0

The devices bear the following marking:



Bad Salzufen
07 Jan 2025

A handwritten signature in blue ink, appearing to be 'T. Malischewski', written over a horizontal line.

T. Malischewski
Managing Director



8.2 EAC Deklaration

ЕВРАЗИЙСКИЙ ЭКОНОМИЧЕСКИЙ СОЮЗ ДЕКЛАРАЦИЯ О СООТВЕТСТВИИ



Заявитель Общество с ограниченной ответственностью «МАТИС-М»

Место нахождения: Российская Федерация, Москва, 117261, улица Вавилова, дом 70, строение 3, Комната Правления. Адрес места осуществления деятельности: Российская Федерация, Москва, 109029, Сибирский проезд, дом 2, строение 9. Основной государственный регистрационный номер: 1037739575125, номер телефона: +74957252309, адрес электронной почты: info@matis-m.ru,
в лице Генерального директора Шарова Александра Анатольевича

заявляет, что Измерительные устройства: Манометры для измерения дифференциального давления, серии DS, DA

Изготовитель FISCHER Mess- und Regeltechnik GmbH. Место нахождения и адрес места осуществления деятельности: Германия, Bielefelder Str. 37a D-32107 Bad Salzuflen Germany, координаты системы ГЛОНАСС (52.056894, 8.725524)

Продукция изготовлена в соответствии с Директивой 2014/35/EU

Код ТН ВЭД ЕАЭС 9026 20 400 0 Серийный выпуск

соответствует требованиям

ТР ТС 004/2011 О безопасности низковольтного оборудования

Декларация о соответствии принята на основании

Протокол испытаний № АЛС-011-0163 от 27.01.2022 года, выданного испытательной лабораторией Общества с ограниченной ответственностью «АТМОСФЕРА», аттестат аккредитации РОСС RU.32468.04ЛЕГО.002

Схема декларирования 1д

Дополнительная информация

Условия и сроки хранения стандартные при нормальных значениях климатических факторов внешней среды, срок службы (годности) указан в эксплуатационной документации. Договор на выполнение функций иностранного изготовителя № 2016-09-29/01 от 29.09.2016.

Декларация о соответствии действительна с даты регистрации по 27.01.2027 включительно

(подпись)



М. П.

Шаров Александр Анатольевич

(Ф.И.О. заявителя)

Регистрационный номер декларации о соответствии: ЕАЭС N RU Д-DE.PA01.B.43065/22

Дата регистрации декларации о соответствии: 28.01.2022

Fig. 17: EAC_RU_DS-DA

8.3 SIL Certificate



ZERTIFIKAT CERTIFICATE

Hiermit wird bescheinigt, dass das unten beschriebene Produkt der Firma
This certifies that the product mentioned below from company

Fischer Mess- und Regeltechnik
Bielefelder Straße 37a
32107 Bad Salzuflen
Deutschland

die Anforderungen der folgenden Prüfunterlage(n) erfüllt.
fulfills the requirements of the following test regulations.

Geprüft nach: **EN 61508:2010 Teile/Parts 1-7**
Tested in accordance with:

Beschreibung des Produktes: **Differenzdruck Mess- und Schaltgerät / Differential Pressure Switch**
 (Details s. Anlage 1) **Kontaktmanometer / Contact Pressure Gauge**
Description of product:
 (Details see Annex 1)

Typenbezeichnung: **DS11, DS13 und DS21**
Type Designation: **MS11**

Dieses Zertifikat bescheinigt das Ergebnis der Prüfung an dem vorgestellten Prüfgegenstand. Eine allgemein gültige Aussage über die Qualität der Produkte aus der laufenden Fertigung kann hieraus nicht abgeleitet werden.
This certifies the result of the examination of the product sample submitted by the manufacturer. A general statement concerning the quality of the products from the series manufacture cannot be derived there from.

Registrier-Nr. / Registered No. 44 799 13759902
 Prüfbericht Nr. / Test Report No. 3526 2583
 Aktenzeichen / File reference 8003015248

Gültigkeit / Validity
 von / from 2020-03-18
 bis / until 2025-03-17

 Zertifizierungsstelle der
 TÜV NORD CERT GmbH

Essen, 2020-03-18

TÜV NORD CERT GmbH Langemarckstraße 20 45141 Essen www.tuev-nord-cert.de technology@tuev-nord.de

Bitte beachten Sie auch die umseitigen Hinweise
Please also pay attention to the information stated overleaf

Fig. 18: SIL_4479913759902



ANLAGE ANNEX

Anlage 1, Seite 1 von 1
Annex 1, page 1 of 1

zum Zertifikat Registrier-Nr. / to Certificate Registration No. 44 799 13759902

Allgemeine Angaben
General Information

Siehe auch Seite 1 des Zertifikats
See also page 1 of the certificate

Produktbeschreibung:
Product description:

Differenzdruck Mess- und Schaltgerät / Differential Pressure Switch DS11, DS13, DS21
Kontaktmanometer / Contact Pressure Gauge MS11

Technische Daten:
Technical data:

Sicherheitsparameter / Safety Parameter
SFF = 70 %
PFH = $3,3 \cdot 10^{-11}$ 1/h
HFT = 0
Typ-A-Teilkomponente / Type

Die Geräte können mit einer geeigneten Testung in SIL2 Anwendungen eingesetzt werden.
The components can be used with an appropriate testing in SIL2 applications.

Zertifizierungsstelle der
TÜV NORD CERT GmbH

Essen, 2020-03-18

TÜV NORD CERT GmbH

Langemarckstraße 20

45141 Essen

www.tuev-nord-cert.de

technology@tuev-nord.de

Fig. 19: SIL_4479913759902

8.4 DNV-GL Certificate



DNV·GL

Certificate No:
TAA00002BW

TYPE APPROVAL CERTIFICATE

This is to certify:

That the Pressure Indicator

with type designation(s)
DS11, DS21

Issued to

FISCHER Mess- und Regeltechnik GmbH
Bad Salzuflen, Nordrhein-Westfalen, Germany

is found to comply with

DNV GL rules for classification – Ships, offshore units, and high speed and light craft

Application :

Product(s) approved by this certificate is/are accepted for installation on all vessels classed by DNV GL.

Location classes:

Temperature B
Humidity B
Vibration A*
EMC N/A
Enclosure B (IP54)

Issued at **Hamburg** on **2019-06-03**

This Certificate is valid until **2024-06-02**.

DNV GL local station: **Magdeburg**

Approval Engineer: **Holger Jansen**



Digitally Signed By: Rinkel, Marco

for **DNV GL**

Location: Hamburg, on behalf of

Joannis Papanuskas
Head of Section

This Certificate is subject to terms and conditions overleaf. Any significant change in design or construction may render this Certificate invalid. The validity date relates to the Type Approval Certificate and not to the approval of equipment/systems installed.



Form code: TA 251

Revision: 2016-12

www.dnvgl.com

Page 1 of 3

© DNV GL 2014. DNV GL and the Horizon Graphic are trademarks of DNV GL AS.

Fig. 20: DNV-GL_TAA00002BW_(1)

Job Id: **262.1-030917-1**
 Certificate No: **TAA00002BW**

Product description

Pressure Indicator and Switching Device

Type: DS11, DS21

Pressure indicator: 270° scale, Indicator class: 2.5

Ranges	Max. Static Pressure DS11 [DS21]
0 - 400 mbar	6 [6] bar
0 - 0.6 bar	10 [10] bar
0 - 1 bar	16 [16] bar
0 - 1.6bar; 0 - 2.5bar; 0 - 4bar; 0 - 6bar	25 [16] bar
0 - 10 bar [only DS11]	25 bar

Max. medium temperature: 70° C
 Gasket and membrane: NBR or Viton
 Wetted parts: 1.4310, 1.4305
 Pressure gauge: GKAlSi 10(MgCu), with hart coat or 1.4305
 Output: 2 c/o - contacts separate adjustable
 Rating: 3A, 250 V AC, 250 VA
 Electrical connection: fixed cable, length 3m, type MPRX 0,6/1 (Nexans) or equivalent

Type DS21: identical technical data, gaskets and membrane = viton

Application/Limitation

The Type Approval covers hardware listed under Product description. When the hardware is used in applications to be classed by DNV GL, documentation for the actual application is to be submitted for approval by the manufacturer of the application system in each case. Reference is made to DNV GL Rules for Ships Pt.4 Ch.9 Control and Monitoring Systems.

A* Vibration test: 2 to 17 Hz amplitude = 1.6 mm,
 17 to 100 Hz acceleration = 2g

Type Approval documentation

Data sheets: DS11, Rev.B 2014-08
 DS21, Rev.B 2014-08
Drawings: DS11 Dwg.-no. 24855, Rev.d; 2019-02-13
 DS11 Dwg.-no. 02.011.00.24857.3, Rev.e; 2018-02-06
 DS21 Dwg.-no. 26023, Rev.g; 2019-02-15
 DS21 Dwg.-no. 02.021.00.26067.3, Rev.h; 2018-02-12
 DS11-DS21 Dwg.-no. 02.021.01.34017.3, Rev.a; 2011-02-08
Test reports: TÜV 57 011 7, 1982-06-04
 Type Approval Assessment Report 2019-05-21

Tests carried out

Applicable tests according to DNV GL Class Guideline CG0339, November 2016.

Marking of product

The products to be marked with:

- Model name
- Manufacturer name
- Serial number



Job Id: **262.1-030917-1**
Certificate No: **TAA00002BW**

Periodical assessment

The scope of the periodical assessment is to verify that the conditions stipulated for the type are complied with, and that no alterations are made to the product design or choice of systems, software versions, components and/or materials.

The main elements of the assessment are:

- Ensure that type approved documentation is available
- Inspection of factory samples, selected at random from the production line (where practicable)
- Review of production and inspection routines, including test records from product sample tests and control routines
- Ensuring that systems, software versions, components and/or materials used comply with type approved documents and/or referenced system, software, component and material specifications
- Review of possible changes in design of systems, software versions, components, materials and/or performance, and make sure that such changes do not affect the type approval given
- Ensuring traceability between manufacturer's product type marking and the type approval certificate

Periodical assessment is to be performed after 2 years and after 3.5 years. A renewal assessment will be performed at renewal of the certificate.

END OF CERTIFICATE

8.5 DIN CERTCO certification DIN 4754-2



CERTIFICATE

Certificate holder	FISCHER Mess- und Regeltechnik GmbH Bielefelder Str. 37a 32107 Bad Salzuflen GERMANY
Product	Flow switches for heat transfer installations
Type, Model	DS21...
Testing basis	DIN 4754-2:2015-03 Zertifizierungsprogramm Strömungs- und Füllstandsicherungen (2016-01)
Mark of conformity	
Registration No.	10S001
Valid until	2025-10-31
Right of use	This certificate entitles the holder to use the mark of conformity shown above in conjunction with the specified registration number. See annex for further information.

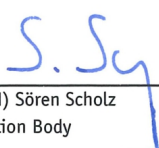
2020-12-21 
Dipl.-Wi.-Ing. (FH) Sören Scholz
Head of Certification Body





ANNEX

Page 1 of 1

Certificate	10S001 dated 2020-12-21
Technical Data	Model: differential pressure gauge Operating pressure: 6 bar, 10 bar and 16 bar (according to design) Rated voltage: 250 V AC, 5 A or 30 V DC, 0,4 A Switching hysteresis: 2,5 % accumulated value of measuring range
Testing laboratory/ Inspection body	TÜV Rheinland Industrie Service GmbH Am Grauen Stein 51105 Köln GERMANY
Test report(s)	SSW 1710/15 dated 2015-10-07 968/FI 1018.00/18 dated 2018-09-24 968/FI 1018.01/19 dated 2019-09-27 968/FSP 2160.00/20 dated 2020-11-25



8.6 EC type examination according to 2014/68/EU



ZERTIFIKAT CERTIFICATE

**EU-Baumusterprüfbescheinigung (Baumuster) - Modul B -
nach Richtlinie 2014/68/EU**
**EU type-examination certificate (production type) - module B -
according to directive 2014/68/EU**

Zertifikat-Nr.: 0045/202/1403/Z/01262/22/D/001(00)
Certificate No.:

Name und Anschrift des Herstellers: Fischer Mess- und Regeltechnik GmbH
Name and address of manufacturer: Bielefelder Straße 37a
 32107 Bad Salzufen

Hiermit wird bescheinigt, dass das unten genannte Baumuster die Anforderungen der Richtlinie 2014/68/EU erfüllt.

We hereby certify that the type examination mentioned below fulfills the requirements of directive 2014/68/EU.

Prüfgrundlage: Test specification:	EN 837-1
Prüfbericht-Nr.: Test report No.:	0045/202/1403/P/01262/22/D/001(00)
Beschreibung des Baumusters Description of production type	Differenzdruck Mess- und Schaltgerät DS 21 pressure difference contactor and measurement device
Fertigungsstätte Place of manufacture:	Fischer Mess- und Regeltechnik GmbH Bielefelder Straße 37a 32107 Bad Salzufen
Gültig bis: Valid until:	08/2032

Anlagen:
Attachment
--



Notifizierte Stelle 0045 für Druckgeräte
Notified Body 0045 for pressure equipment



Digital unterschrieben
von Kocielnik Bodo
Datum: 2022.12.13
15:33:56 +01'00'

TÜV NORD Systems GmbH & Co. KG, Große Bahnstraße 31, 22525 Hamburg

Kontakt / Contact:
E-Mail imruhgebietost@tuev-nord.de
Tel./Phone +49(0) 231-5186-0

Zur Verifizierung der Gültigkeit eines digital signierten Dokuments ist die Installation des TÜV NORD GROUP Stammzertifikats notwendig: <https://www.tuev-nord.de>, siehe Kunden-Login/Digitale Signatur
 To verify the validity of a digitally signed document, an installation of the TÜV NORD GROUP root certificate is required: <https://www.tuev-nord.de/en/company>, see Customer Login/Digital Signature

B EU Baumuster Druckgerät und Baugruppe deu eng digital Rev. 3 / 06.20

Fig. 25: Type examination certificate module B

8.7 Part test current 100



Bescheinigung Certificate

über die Zuerkennung eines Bauteil-
kennzeichens für *for the grant of a type test approval
mark in respect of*

Strömungswächter/-begrenzer

Aufgrund eines Prüfberichts
zur Bauteilprüfung des *In virtue of a test report
concerning by*

TÜV Rheinland von 2020-11-25

wird dem Antragsteller, der Firma *the applicant, the company*

**Fischer Mess- und Regeltechnik GmbH
Bielefelder Straße 37a; 32107 Bad Salzuflen**

zuerkannt das Bauteilkennzeichen-Nr. *is granted the type test approval mark No.*

TÜV . SW/SB . 20 - 020

für *for*

Differenzdruckgerät

Typ *type*

DS21...

Die Zuerkennung erfolgt in Anwendung von *The adjudication is made pursuant to*
VdTÜV-Merkblatt Strömung 100, Ausgabe 2017-03-15 in Verbindung mit VdTÜV-Merk-
blatt Allgemeines 002; grundlegende Sicherheitsanforderungen der Richtlinie 2014/68/EU
(Druckgeräterichtlinie); DIN 4754-2:2015-03

Sie ist bis **2025-11-30** *It expires 2025-11-30*
befristet und kann widerrufen werden. *and is revocable.*

Die Bescheinigung von 2015-11-30
wird hierdurch ersetzt. *The certificate dated 2015-11-30
is replaced herewith.*

Hinweis: Der Hersteller oder Importeur ist verpflichtet, den
zuständigen Sachverständigen zu beauftragen, Bauteile aus der
laufenden Fertigung auf Übereinstimmung mit dem Baumuster
einmal jährlich stichprobenweise zu überprüfen.

Note: The manufacturer or importer is obliged to the competent
Authorized Inspector to conduct a random check on the
accessories concerning identity to the type once a year. The
accessories have to be taken from the current production.

Berlin, 2021-02-17
Blo/Hel

Verband der TÜV e.V.
Geschäftsbereich Anlagentechnik,
Arbeitswelt, Systemsicherheit
- Zertifizierungen und Registrierungen -

Blohm

Verband der TÜV e.V. · Friedrichstraße 136 · 10117 Berlin · Deutschland
Telefon +49 30 760095-400 · Telefax +49 30 760095-401 · Internet: www.vdtuev.de

Fig. 26: Part test current 100

8.8 Type test flow limiter DIN EN 12952-11

TÜV Rheinland Energy GmbH

Test Centre for Energy Appliances

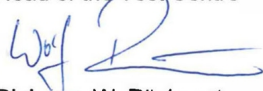

Type test of a flow limiter DIN EN 12952-11:2007.09 / DIN EN 12953-9:2007.09

Manufacturer / Client:	Fischer Mess- und Regeltechnik GmbH Bielefelder Straße 37a 32107 Bad Salzufen
Product:	Flow limiter
Type designation:	DS21
Test object:	Differential pressure transducer with switching contact
Technical data:	
Measurement range	0...6 bar (different versions see chapter 2)
Nominal pressure	25 bar
Switching current	AC 250 V / 5 A oder DC 30 V / 0,4 A
Hysteresis	2,5% of upper full scale
Accuracy	2,5% of upper full scale
Ambient temperature	-10 ... 70°C
Media temperature	-10 ... 70°C
Class of protection (EN 60529)	IP55 / IP65 (depending on version)
Process connection	G ¼ oder compression fitting
Cause of test:	Proof of compliance with the requirements of above listed test standards
Test result:	The test object meets the requirements of above listed test standards
Remarks:	The differential pressure transducer is certified according to the Pressure Equipment Directive 97/23/EC. Essential test results were adopted from test reports of TÜV Nord (see related test reports). To exclude the fault condition „contact welding“ the installation manual must give instructions for installation of a fuse with a rated trip current of 0.6-times of the nominal switching current.
Köln, 12 th of May, 2016 432/rw Expert	Test Centre for Energy Appliances Head of the Test Centre
 Dirk Wilczek	 Dipl.-Ing. W. Rückwart

Order no. 21234771

Seite 3 / 19

Report no. S 481 2016 S4

Fig. 27: BMP_DIN_EN_12952-11

Notes

Notes



FISCHER Mess- und Regeltechnik GmbH

Bielefelder Str. 37a
D-32107 Bad Salzuflen

Tel. +49 5222 974-0

Fax +49 5222 7170

www.fischermesstechnik.de
info@fischermesstechnik.de