



Ex II 3G Ex nA IIC T4 Gc
-20 °C ≤ Ta ≤ +60°C



Operation manual

ME50 ... R

Programmable pressure transducer / pressure switch
for explosive areas

Gas explosion protection zone 2, gases and vapours

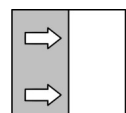

Masthead

Manufacturer:**FISCHER Mess- und Regeltechnik GmbH**Bielefelderstr. 37a
D-32107 Bad SalzuflenTelephone: +49 5222 974 0
Telefax: +49 5222 7170eMail: info@fischermesstechnik.deweb: www.fischermesstechnik.de**Technical editorial team:**

Documentation representative: T. Malischewski

Technical editor: R. Kleemann

All rights, also those to the translation, reserved. No part of this document may be reproduced or processed, duplicated or distributed using electronic systems or any other form (print, photocopy, microfilm or another process) without the written consent of the company FISCHER Mess- und Regeltechnik GmbH, Bad Salzuflen.

Reproduction for internal use is expressly allowed.

Brand names and procedures are used for information purposes only and do not take the respective patent situation into account. Great care was taken when compiling the texts and illustrations; Nevertheless, errors cannot be ruled out. The company FISCHER Mess- und Regeltechnik GmbH will not accept any legal responsibility or liability for this.

Subject to technical amendments.



Version history

Rev. ST4-A 08/16	Version 1 (first edition)
Rev. ST4-B 09/17	Version 2 (corrections)
Rev. ST4-C 03/22	Version 3 (2L version not applicable)

Table of Contents

1 Safety guidelines	4
1.1 General.....	4
1.2 Personnel Qualification.....	4
1.3 Risks due to Non-Observance of Safety Instructions	4
1.4 Safety Instructions for the Operating Company and the Operator	4
1.5 Unauthorised Modification	5
1.6 Inadmissible Modes of Operation	5
1.7 Safe working practices for maintenance and installation work	5
1.8 Pictogram explanation	6
2 Product and functional description	7
2.1 Delivery scope	7
2.2 Performance characteristics	7
2.3 Use as intended.....	7
2.4 Function diagram.....	8
2.5 Design and mode of operation	8
2.6 Product overview	9
2.7 Type plate.....	9
3 Installation and assembly	10
3.1 Generalities	10
3.2 Process connection	10
3.3 Electrical connections.....	10
3.3.1 Ground connection.....	11
4 Commissioning.....	13
4.1 General.....	13
4.2 Control Elements	13
4.3 Parameters	14
4.4 Parameter list	15
5 Technical Data	19
5.1 Generalities	19
5.2 Input variables	19
5.3 Output parameters.....	20
5.4 Measurement accuracy	20
5.5 Auxiliary energy	20
5.6 Application conditions.....	21
5.7 Construction design.....	21
5.8 Parameters	22
6 Order Codes	23
6.1 Accessories	24
7 Attachments	25
7.1 EU Declaration of Conformity	25

1 Safety guidelines

1.1 General

This operating manual contains basic instructions for the installation, operation and maintenance of the device that must be followed without fail. It must be read by the installer, the operator and the responsible specialist personnel before installing and commissioning the device.

This operating manual is an integral part of the product and therefore needs to be kept close to the instrument in a place that is accessible at all times to the responsible personnel.

The following sections, in particular instructions about the assembly, commissioning and maintenance, contain important information, non-observance of which could pose a threat to humans, animals, the environment and property.

The instrument described in these operating instructions is designed and manufactured in line with the state of the art and good engineering practice.

1.2 Personnel Qualification

The instrument may only be installed and commissioned by specialized personnel familiar with the installation, commissioning and operation of this product.

Specialized personnel are persons who can assess the work they have been assigned and recognize potential dangers by virtue of their specialized training, their skills and experience and their knowledge of the pertinent standards.

For explosion-proof models the specialized personnel must have received special training or instruction or be authorized to work with explosion-proof instruments in explosion hazard areas.

1.3 Risks due to Non-Observance of Safety Instructions

Non-observance of these safety instructions, the intended use of the device or the limit values given in the technical specifications can be hazardous or cause harm to persons, the environment or the plant itself.

The supplier of the equipment will not be liable for damage claims if this should happen.

1.4 Safety Instructions for the Operating Company and the Operator

The safety instructions governing correct operation of the instrument must be observed. The operating company must make them available to the installation, maintenance, inspection and operating personnel.

Dangers arising from electrical components, energy discharged by the medium, escaping medium and incorrect installation of the device must be eliminated. See the information in the applicable national and international regulations.

Please observe the information about certification and approvals in the Technical Data section.

The instrument must be decommissioned and secured against inadvertent re-operation if a situation arises in which it must be assumed that safe operation is no longer possible. Reasons for this assumption could be:

- evident damage to the instrument
- failure of the electrical circuits
- longer storage outside the approved temperature range.
- considerable strain due to transport

Repairs may be carried out by the manufacturer only.

A professional single conformity inspection as per DIN EN 61010, section 1, must be carried out before the instrument can be re-commissioned. This inspection must be performed at the manufacturer's location. Correct transport and storage of the instrument are required.

1.5 Unauthorised Modification

Modifications of or other technical alterations to the instrument by the customer are not permitted. This also applies to replacement parts. Only the manufacturer is authorised to make any modifications or changes.

1.6 Inadmissible Modes of Operation

The operational safety of this instrument can only be guaranteed if it is used as intended. The instrument model must be suitable for the medium used in the system. The limit values given in the technical data may not be exceeded.

The manufacturer is not liable for damage resulting from improper or incorrect use.

1.7 Safe working practices for maintenance and installation work

The safety instructions given in this operating manual, any nationally applicable regulations on accident prevention and any of the operating company's internal work, operating and safety guidelines must be observed.

The operating company is responsible for ensuring that all required maintenance, inspection and installation work is carried out by qualified specialized personnel.

1.8 Pictogram explanation



DANGER

Type and source of danger

This indicates a **direct** dangerous situation that could lead to death or **serious injury** (highest danger level).

1. Avoid danger by observing the valid safety regulations.



WARNING

Type and source of danger

This indicates a **potentially** dangerous situation that could lead to death or **serious injury** (medium danger level).

1. Avoid danger by observing the valid safety regulations.



CAUTION

Type and source of danger

This indicates a **potentially** dangerous situation that could lead to slight or serious injury, damage or **environmental pollution** (low danger level).

1. Avoid danger by observing the valid safety regulations.



NOTICE

Note / advice

This indicates useful information of advice for efficient and smooth operation.

2 Product and functional description

2.1 Delivery scope

- Programmable pressure transducer / switch ME50
- User Manual

2.2 Performance characteristics

Important features

- Digital measured value display
- Highly precise
- Low hysteresis
- Can be configured
- Turn down 1:5
- Optional switch output
- Robust device model
- Large vibration resistance

Typical applications

- Pressure monitoring
- Content measurement

Application areas

- Procedural engineering
- Process technology
- Environmental technology
- Regenerative energies (biogas, etc.)

2.3 Use as intended

The ME50 is suitable for measuring relative pressure and under-pressure in fluid or gas-like, neutral, non-aggressive media.

If there is dirty or aggressive media in the system, or if this is to be expected, the device must be modified in terms of those parts that come into contact with the media. The device is to be exclusively used for the applications agreed between the manufacturer and the user.

Explosion hazard area classification

The pressure transducer is suitable as 'Electrical equipment for use in potentially explosive areas', Zone 2 - (Gases and vapours).

Designation as per guideline 2014/34/EU (ATEX):

⊕ II 3G Ex nA IIC T4 Gc

-20 °C ≤ Ta ≤ +60°C

2.4 Function diagram

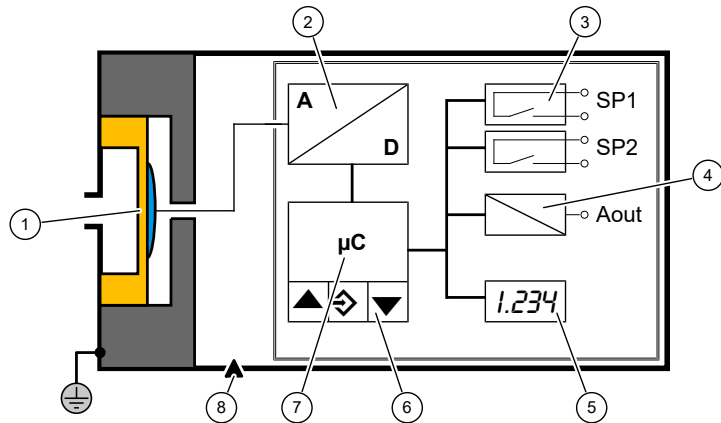

Fig. 1: Function diagram

1	Sensor	2	Signal converter
3	Switching outputs	4	Analogue output
5	Measured value display	6	Keyboard
7	Microcontroller	8	Pressure equalisation

2.5 Design and mode of operation

Depending on the measuring range, the ME50 is produced with a ceramic or a piezo-resistive measuring cell. Two switch outputs are also possible in the version with a 3-conductor connection.

Ceramic measuring cell

In the ceramic measuring cell, the pressure acts directly on the ceramic membrane which in turn deforms. The membrane is constructed electrically like a plate capacitor whose capacity change is proportional to the effective pressure. The electronics that are controlled by a micro-controller implement this change in capacitance into an standard electrical signal.

Piezo-resistive measuring cell

In the piezo-resistive measuring cell, the pressure is applied to a silicon membrane into which the deformation-dependent resistances have been diffused. The material resistance changes proportionally to the effective pressure. The electronics that are controlled by a micro-controller implement this change in resistance into an standard electrical signal.

2.6 Product overview

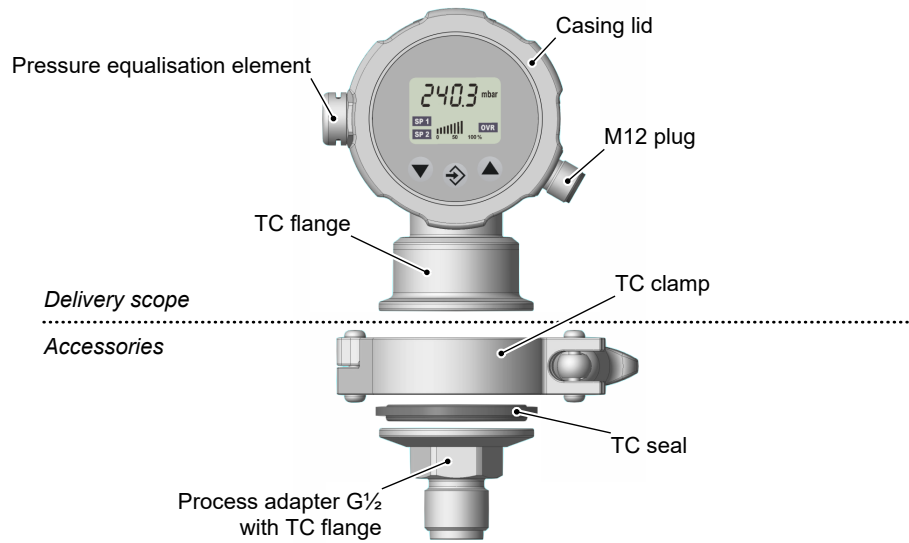

Fig. 2: Product overview

2.7 Type plate

This type plate serves as an example of the information that is stated. The data shown is purely fictive, but does correspond to the actual conditions. For more information, please see the order code at the end of these instructions.

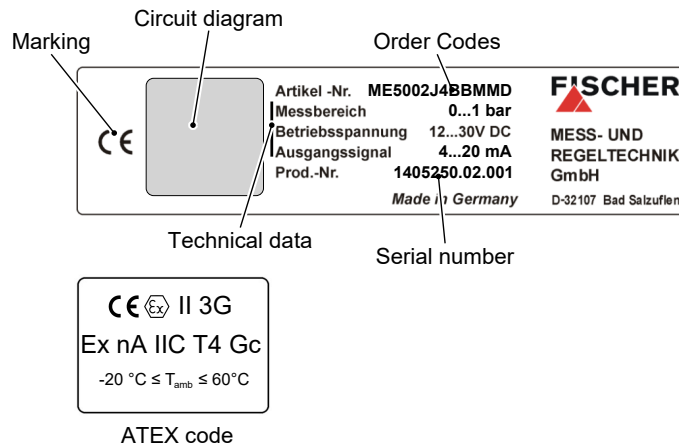

Fig. 3: Nameplate

3 Installation and assembly

3.1 Generalities

The unit is designed for vertical installation (process connection facing down) and compared. No other installation positions are planned.

3.2 Process connection

- By authorized and qualified specialized personnel only.
- The pipes need to be depressurized when the instrument is being connected.
- Appropriate steps must be taken to protect the device from pressure surges.
- Check that the device is suitable for the medium being measured.
- Maximum pressures must be observed (cf. Tech. data)

The process connection of the ME50 is realised with a terminal clamp (Tri Clamp) acc. to DIN 32676.

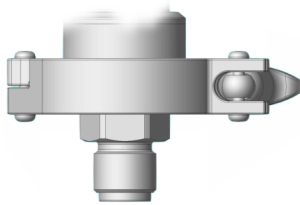

Fig. 4: Tri Clamp connection

The pressure lines must be installed at an inclination so that when fluids are measured no air pockets are created or when measuring gases, no water pockets are created. If the required inclination is not reached, water or air filters must be installed at suitable places.

The pressure lines must be kept as short as possible and installed without any tight bends to avoid delays.

The pressure lines need to be vented for fluid measuring media.

If water is used as a measuring medium, the unit must be protected against frost.

If the pressure sensing lines are already pressurised at the time of commissioning, zero-point control and adjustment cannot be performed. In such cases, the device should be only connected to the mains without the pressure sensing lines.

3.3 Electrical connections



⚠ WARNING

Operation in areas at risk of explosion

If operated in explosive areas, the electrical data of the unit and the valid local regulations and guidelines for the installation and operation of electrical systems in explosive areas must be observed. (e.g. DIN EN 60079)

The electrical connection may only be realised by authorised and qualified specialists that have undergone additional training or briefings or have a permit to work on explosion-protected units in potentially explosive systems.

Risks emanating from electrical current or voltage should be prevented by means of suitable action.

- When connecting the unit, the national and international electro-technical regulations must be observed.
- Disconnect the system from the mains, before electrically connecting the device.
- Do not connect the connector if strained.
- A CE-conform mains adapter with a slow 200 mA fuse only may be used in the power supply circuit.

The nominal supply voltage and the permissible range can be found in the technical data.

The admissible load / resistance is stated in the technical data.

3.3.1 Ground connection



Ground connection

The outer ground connection must always be connected to the protective potential equalisation or a similar local potential equalisation.

The ground terminal is suitable for connecting fine-wire conductors up to 4 mm² or single-wire conductors up to 6 mm².

3.3.2 3-conductor version

Fig. 5: Ground connection

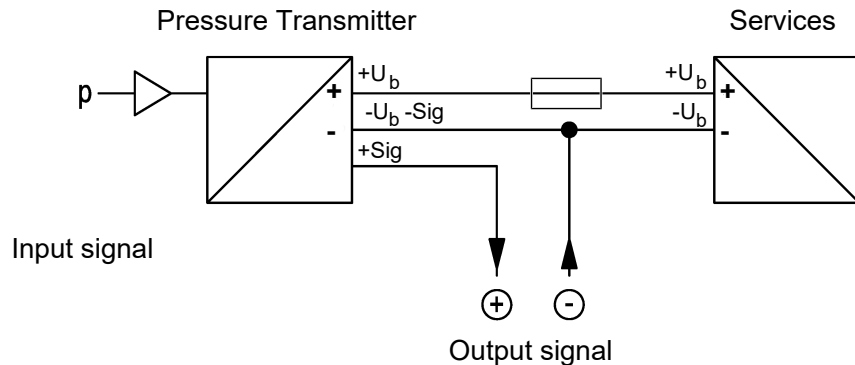

Fig. 6: 3L Circuitry

Without switch output

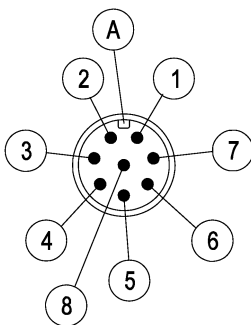

Fig. 7: M12 connector 8-pin

With switch output

PIN	Signal name		Cable colour
1	Outlet	+Sig	white
2	Services	+U _b	brown
3	---	n.c	green
4	---	n.c	yellow
5	---	n.c	grey
6	---	n.c	pink
7	Services	-U _b	blue
8	Functional earth	FE	rot
A	Coding A		

Table 1: Supply, and output signal

There are three options available for the semiconductor switch contacts K1 and K2.

1. Potential-free
2. PNP-switching In this version, the connections K1(b) and K2(b) are connected with +U_b ex-works. The switch output is called PNP1 or PNP2.
3. NPN-switching In this version, the connections K1(b) and K2(b) are connected with -U_b ex-works. The switch output is called NPN1 or NPN2.

Please note that the type of switch contact can be programmed and can work both as an NC or NO contact. For reasons of simplicity, they are shown as NC contacts in this connection description.

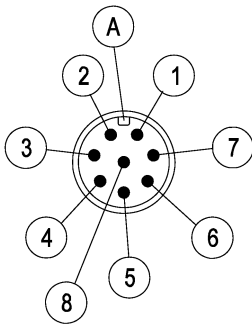

Fig. 8: M12 connector 8-pin

Potential-free contacts

Pin	Signal name		Cable colour
1	Output		+Sig white
2	Operating voltage		+U _b brown
3	Switching output 1		K1 (a) green
4	Switching output 1		K1 (b) yellow
5	Switching output 2		K2 (b) grey
6	Switching output 2		K2 (a) pink
7	Operating voltage		-U _b blue
8	Functional earth		FE red
A	Coding A		

Table 2: Power supply, output signal and switching contacts

PNP-switching

Pin	Signal name		Cable colour
1	Output		+Sig white
2	Operating voltage		+U _b brown
3	Switching output 1		PNP1 green
4	---		n.c. yellow
5	Switching output 2		PNP2 grey
6	---		n.c. pink
7	Operating voltage		-U _b blue
8	Functional earth		FE red
A	Coding A		

Table 3: Power supply, output signal and PNP switching contacts

NPN-switching

Pin	Signal name		Cable colour
1	Output		+Sig white
2	Operating voltage		+U _b brown
3	Switching output 1		NPN1 green
4	---		n.c. yellow
5	Switching output 2		NPN2 grey
6	---		n.c. pink
7	Operating voltage		-U _b blue
8	Functional earth		FE red
A	Coding A		

Table 4: Power supply, output signal and NPN switching contacts

4 Commissioning

4.1 General

All electrical supply, operating and measuring lines, and the pressure connections must have been correctly installed before commissioning. All supply lines are arranged so that there are no mechanical forces acting on the device.

Check that the pressure connections do not leak before commissioning.

4.2 Control Elements

4.2.1 Advertisement

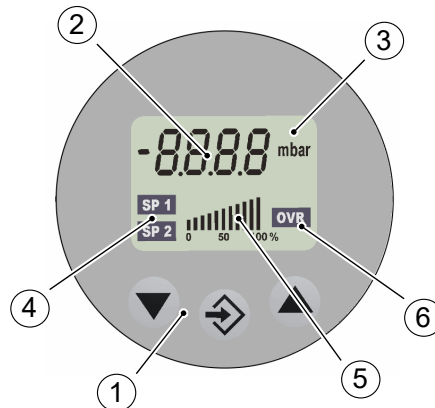

Fig. 9: Measured value display

1	Keyboard	2	Measured Value Display
3	Unit	4	Switch points
5	Bar chart	6	Overflow

The 3½ digit LCD display represents the current pressure value in normal mode. The unit is shown to the right of the measured value and is set ex-works. The unit cannot be altered on site.

4.2.2 Keyboard

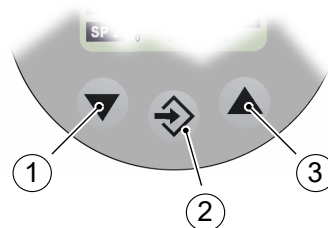

Fig. 10: Keyboard

1	Arrow key down	Menu: downwards	Value: reduce
3	OK key	Menu: open	Value: save
5	Arrow key up	Menu: upwards	Value: increase

It is configured via a 3-key membrane keyboard. The keyboard can only be reached after the housing lid has been removed. This can usually be unscrewed manually. If this is not possible, please use a belt wrench to prevent damage

4.3 Parameters

After it has been switched on, the unit carries out a display test and shows the implemented firmware version for approx. 2s. Then the pressure transmitter switches to the operating mode.

Press the OK key ↵ to enter the configuration mode.

During configuration, the parameter name or the parameter value is shown instead of the measured value. The unit continues to work during configuration and shows pressure changes in the bar chart display. Changes can be followed directly without changing the operating mode.



NOTICE

Time out

If no key is pressed for a longer period (approx. 1 minute), the units switches automatically into work mode.

Set parameters

Proceed as follows to set a parameter:

1. Press the enter OK key to switch to the configuration mode.
2. Use the arrow keys ▼▲ to navigate through the parameter list until you reach the required parameter.
3. Press the enter OK key to call up the parameter. The parameter value is shown.
4. Use the arrow keys ▼▲ to set the required parameter value.
5. Press the enter OK key to save the value. The parameter name is now shown on the display.
6. Use the arrow keys ▼▲ to navigate through the parameter list until you reach the required parameter.
7. Press the enter OK key ↵ to leave to the parameter menu. The pressure transmitter switches to the operating mode.

4.4 Parameter list

The following describes all parameters in the shown list. Please note that some parameters are not available depending on the unit version. For instance, the parameters for the switch points are hidden, if the unit does not have any switch points.

Parameter Escape *ESC*

This parameter is the input and output of the parameter list. It is stated at the start and also at the end of the list.

- If the OK button \diamond is pressed in work mode, the unit switches to the configuration mode. The *ESC* parameter appears on the display.
- To leave the configuration mode, use the arrow keys $\blacktriangle \blacktriangledown$ to set the *ESC* parameter and press the OK button \diamond . The unit switches into work mode.

Parameter measuring range *nR ... nL*

The measuring range within the basic measuring range can be spread (see type plate) using the parameters measuring range start *Enf* and measuring range end *nL*. The spread (Turn down) is maximum 1:5.

$$\text{Turn down} = \frac{\text{Settable measuring span}}{\text{Basic measuring range}}$$

The characteristic curve can also be inverted with these parameters.

- $Enf < nL$: rising characteristic curve
- $nL < Enf$: falling characteristic curve

Please note that the minimum settable measuring span cannot be undercut. Both parameters can be set over the entire basic measuring range. The output signal is automatically scaled to the set measuring range.

Parameter switch points

If the unit has a switch output, the following parameters appear in the list:

Switch point 1: *SPIA SPIE SPIF SPId*

Switch point 2: *SP2A SP2E SP2F SP2d*

As the parameters for both switch points function in the same way, the parameters for switch point 1 (SP1) are explained below.

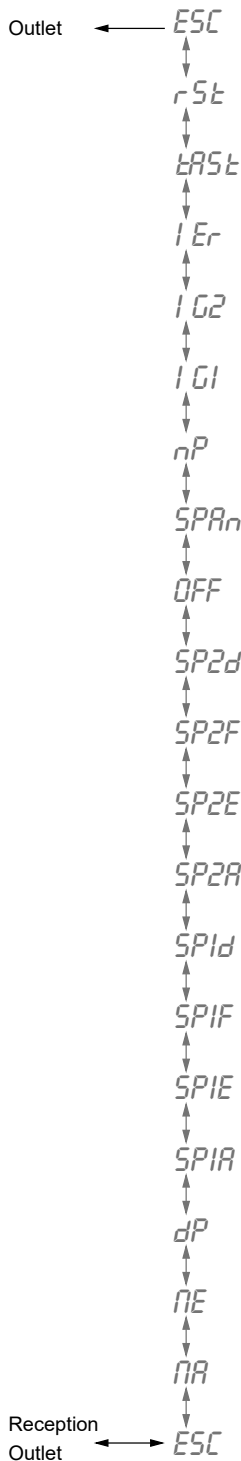

Fig. 11: Parameter list

(i) Parameter activation and deactivation point $SPIA$ $SPIE$

These parameters are used to define the activation and deactivation point. Both parameters can be set individually over the entire basic measuring range.

- $SPIE > SPIA$

If the measured value exceeds the activation point $SPIE$, the contact switches. It is only switched off again, if the measured value undercuts the activation point $SPIA$. (Hysteresis function).

- $SPIE > SPIA$

If the measured value exceeds the activation point $SPIE$, the contact switches. If the measured value undercuts an equally large deactivation point $SPIA$, the contact drops.

- $SPIE < SPIA$

The contact switches if the measured value lies within the range between the activation point $SPIE$ and the deactivation point $SPIA$. If the measured value lies outside this area, the contact drops.

As switched contact is shown in the display as **SP1** or **SP2**.

(ii) Parameter function $SPIF$

The type of contact is defined with this parameter.

$SPIF = 0$

The contact works as an open contact (NO).

$SPIF = 1$

The contact works as an make contact (NC).

**⚠ CAUTION****Power failure**

Please note that the contact is always open if no current flows, regardless of the programmed contact type.

(iii) Parameter damping $SPId$

This parameter allows the reaction of the switch output to be delayed by 0° ... °200 s. This delay applies equally for switching on and off.

Parameter offset correction OFF

This parameter is used to correct an offset, if the measured value at the zero-point deviates from zero. The display shows the current measured value that you can change by up to ±10% of the basic measuring range.

Parameter span correction $SPAN$

This parameter is used to correct an offset of the span, if the measured value at the end or the measuring range deviates from the end value. The display shows the current measured value that you can change by up to ±10% of the basic measuring range.

Parameter zero-point window n^P

In many cases, unsteady readings are not a problem during normal operating mode, but this is not true for the idle state, i.e. if a measured value of zero is expected. The zero-point window parameter is designed for precisely this case.

Its value defines a range of measurement values around zero, for which the measuring value is set to zero. The display only stops showing zero when the measurement leaves the set window. When reaching double the value, the measured value and the reading match again. This avoids jumps in the display.

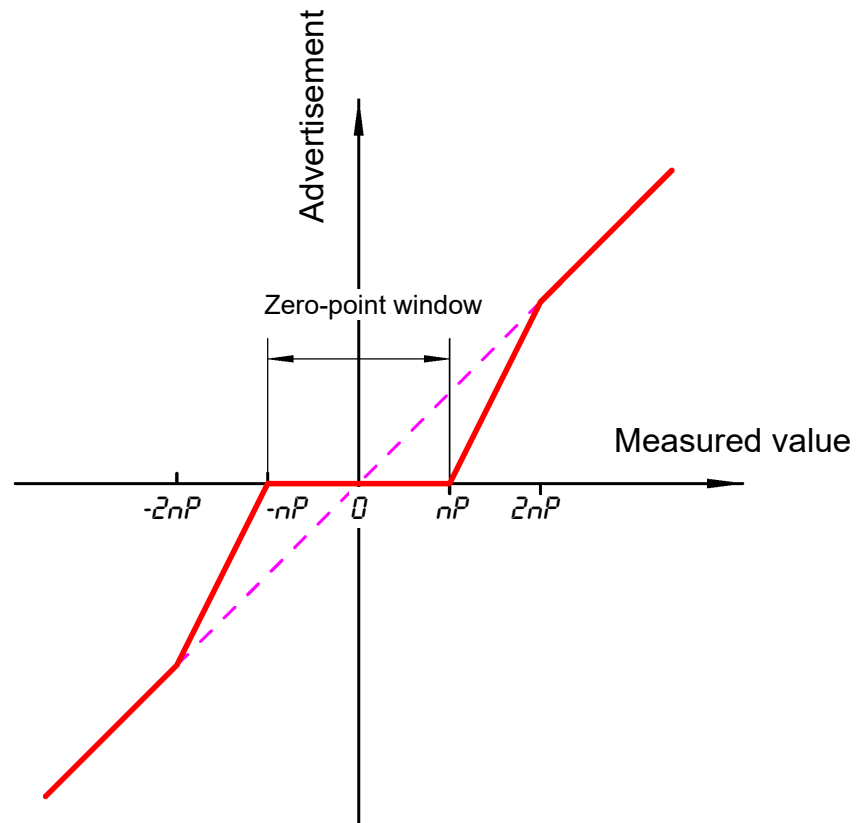

Parameter lower current limit I_{G1}

This parameter defines the lower current limit of the output signal in a value range of 3.5 ... 22.5 mA. The limit is activated with the value 0.

Parameter upper current limit I_{G2}

This parameter defines the upper current limit of the output signal in a value range of 3.5 ... 22.5 mA. The limit is activated with the value 0.

Parameter error signal I_{Er}

This parameter defines the output signal in a value range of 3.5 ... 22.5 mA that should be issued when there is an internal error in the device.

Parameter key lock *lRS t*

The key lock can be activated with this parameter. If no button is pressed within the given time, the keyboard is locked. Unlock the keyboard by interrupting the power supply.

- *lRS t* = 0
The key lock is deactivated
- *lRS t* = 1 ... 100 s
The key lock is activated after the end of a given time.

Parameter reset *rSt*

If the parameter is set to the value 1, all parameters are reset to the default settings.

**NOTICE****User settings**

If the system is reset to the default settings, all user settings are deleted permanently.

5 Technical Data

5.1 Generalities

Reference conditions (acc. to IEC 61298-1)		
Temperature error	+15 ... +25 °C	
Relative humidity	45 ... 75 %	
Air pressure	86 ... 106 kPa	860 ... 1060 mbar
Installation position	User-defined	

5.2 Input variables

Ceramic measuring cell

Measuring range	Smallest measuring span	Over-pressure safety
[mbar]	[mbar]	[bar]
-20 ... +20	10	4
-40 ... +40	20	
-100 ... +100	40	
0 ... 60	12	4
0 ... 100	20	
0 ... 200	40	

Piezo-resistive measuring cell

Measuring range	Smallest measuring span	Over-pressure safety
[mbar]	[mbar]	[bar]
0 ... 400	80	1
0 ... 600	120	3
[bar]	[bar]	[bar]
0 ... 1	0.2	3
0 ... 1.6	0.32	7.5
0 ... 2.5	0.5	7.5
0 ... 4	0.8	15
0 ... 6	1.2	15
0 ... 10	2	30
0 ... 16	3.2	90
-0.6 ... 0	0.12	3.0
-1 ... 0	0.2	3.0
-1 ... +0.6	0.32	3.0
-1 ... +1.5	0.5	7.5
-1 ... +3	0.8	15
-1 ... +5	1.2	15
-1 ... +9	2.0	30
-1 ... +15	3.2	90

The measuring cell can be set within the pre-defined measuring range, which is also stated on the type plate, using the parameters *ENf* and *nL*. The smallest settable measuring span is listed for every measuring range and is a minimum of 1:5 in relation to the basic measuring range.

5.3 Output parameters

The ME50 versions differ in the number and type of outputs available (see order code):

Analog output	0/4 ... 20 mA
Load	$R_L \leq ((U_b - 10 \text{ V}) * 50 \Omega) + 300 \Omega$
Current limitation	approx. 26 mA

Switching output
0 ... 2 Photo MOS relay not short-circuit proof, thermally protected

Contact	U_{max}	I_{max}	R_{ON}
potential-free (AC/DC)	30 V	200 mA	< 1 Ω
PNP/NPN switching (DC)	U _b	200 mA	< 1 Ω

5.4 Measurement accuracy

Accuracy	± 0.2% of measuring range (FS) ¹⁾
Temperature drift	± 0.01% FS/K
Zero point Measuring range	Temperature error band over the compensated temperature range
Compensated measuring range	-10 °C ... +70 °C
Long-term stability	< ±0.1 % FS/year

¹⁾ Includes non-linearity, hysteresis, non-repeatability, zero and full scale deviation. Calibrated in vertical mounting position with process connection downwards.

5.5 Auxiliary energy



⚠ WARNING

Supply circuit

A CE-conform mains adapter with a slow 200 mA fuse only may be used in the power supply circuit.

Rated voltage	24V DC
Perm. operating voltage	12 ... 30 V DC
Power consumption	< 1 W

5.6 Application conditions

Ambient temperature range	without display	-20 °C ... +60 °C
	with display	-20 °C ... +60 °C
Storage temperature range		-10 °C ... +70 °C
Medium temperature range (in operation)		-10 °C ... +85 °C
ATEX		EN 60079-0:2012 + A11:2013 EN 60079-15:2010
EMC		EN 61326-1:2013 EN 61326-2-3:2013
RoHS		EN 50581:2012
Type of protection:		IP 65 acc. to EN 60529

Materials of the parts that come into contact with the surroundings		
Casing		CrNi Steel 1.4404, 1.4571
Process adapter TC	light/solid	CrNi Steel 1.4404
Clamp	High pressure	CrNi Steel 1.4308
TC clamp		CrNi steel 1.4301
Front pane		Safety composite glass
M12 plug		Ms nickel-plated, PA, FKM, Ms

Materials of the parts that come into contact with the measuring medium		
Process adapter TC	light/solid	CrNi Steel 1.4404
Clamp	High pressure	CrNi Steel 1.4308
TC seal		FKM (Viton®)
Sensor membrane	Ceramics	Aluminium oxide ceramic Al ₂ O ₃ (99.9 %)
	Piezo-resistive	CrNi 1.4435

5.7 Construction design.

All dimensions in mm unless otherwise stated

5.7.1 Dimensional picture

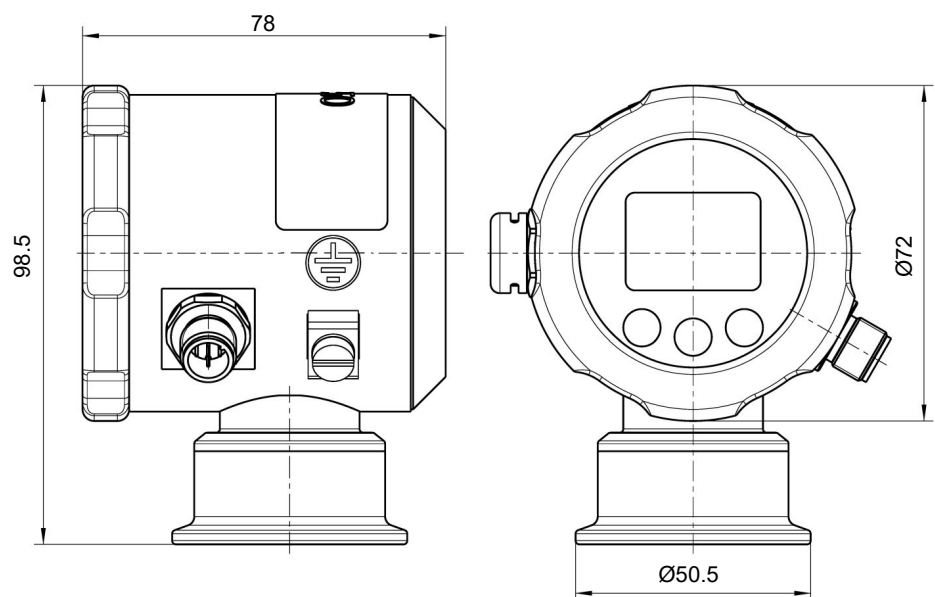

Fig. 12: Dimension drawing

5.7.2 Process connection

The process connection uses a Tri-Clamp connection acc. to DIN 32676. A G $\frac{1}{2}$ inch process adapter with a TC flange can be delivered for this connection.

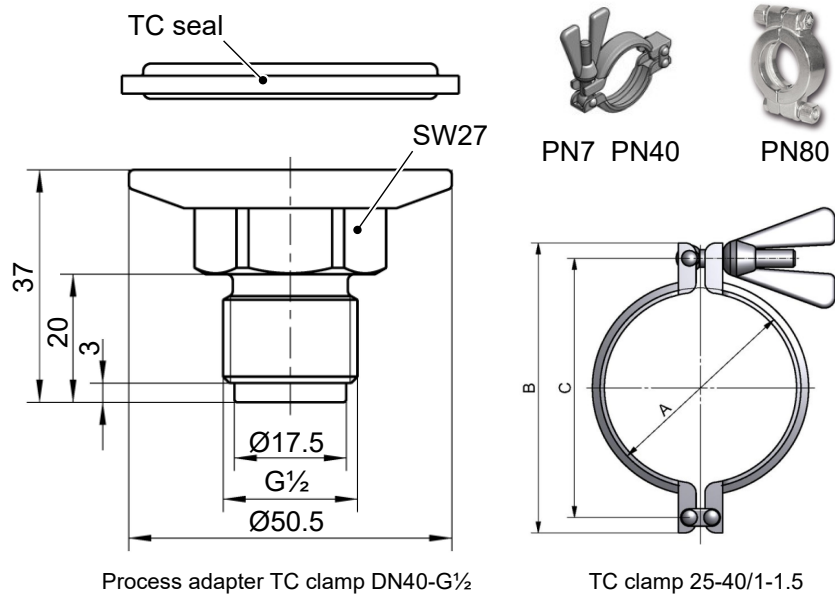

Fig. 13: Dimension drawing process parameters

Planned measures	Operating pressure	A	B	C
TC clamp DN40 light	PN7	53.0	84.5	69.0
TC clamp DN40 solid	PN40	53.0	90.0	57.0
TC clamp DN40 high pressure	PN80	53.5	102	---

Table 5: TC clamp

5.8 Parameters

The device can be configured on site using the membrane keyboard. The housing must be opened for this.

Characteristic curve inversion	Increasing; decreasing
Attenuation	0 ... 200 s
adjustable signal limits	
• upper current limit	3.5 ... 22.5 mA
• lower current limit	3.5 ... 22.5 mA
• Error signal	3.5 ... 22.5 mA
Turn down	1:5

Table 6: Parameters

6 Order Codes

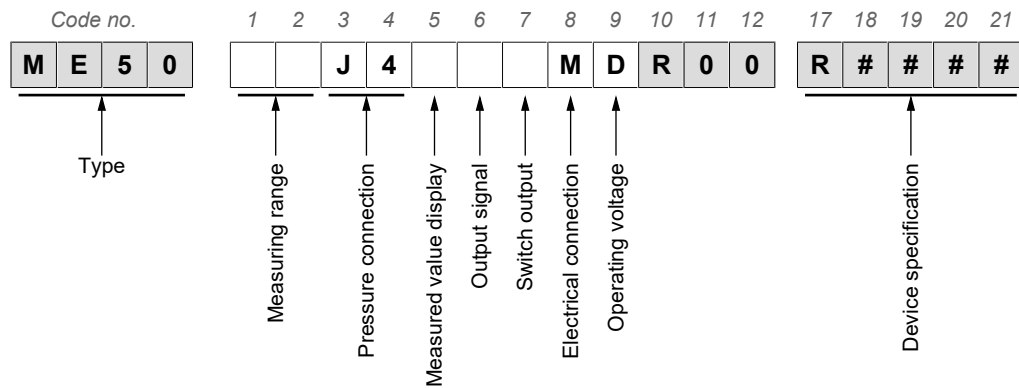

[1,2] Measuring range	Measuring cell	
C7 -20 ... +20 mbar	Ceramic measuring cell	
C5 -40 ... +40 mbar		
B4 -100 ... +100 mbar		
58 0 ... 60 mbar		
59 0 ... 100 mbar		
44 0 ... 200 mbar		
83 0 ... 400 mbar		Piezo-resistive measuring cell
C1 0 ... 600 mbar		
02 0 ... 1 bar		
03 0 ... 1,6 bar		
04 0 ... 2,5 bar		
05 0 ... 4 bar		
06 0 ... 6 bar		
07 0 ... 10 bar		
08 0 ... 16 bar		
30 -0,6 ... 0 bar		
31 -1 ... 0 bar		
32 -1 ... 0,6 bar		
33 -1 ... 1,5 bar		
34 -1 ... 3 bar		
35 -1 ... 5 bar		
36 -1 ... 9 bar		
37 -1 ... 15 bar		

[3,4] Discharge port
J4 Tri Clamp flange connection DN40 DIN 32676 / ISO 2852

[5] Measured value display
A without display
B 3 ½ digit LC-display

[6] Output signal	
A	0 ... 20 mA
P	4 ... 20 mA

[7] Switch output	Electrical connection
M	without switch output
N	2 potential-free semiconductor switches AC/DC
8	2 semiconductor switches PNP-switching DC
9	2 semiconductor switches NPN-switching DC

[8] Electrical connection	
M	M12 plug connection

[9] Operating voltage	
D	24 V DC

Device specification

[17] Ex-Classification	
R	⊕ II 3G Ex nA IIC T4 Gc

[18-21] Order No.	
	####

6.1 Accessories

Order no.	Planned measures
06411173	Process adapter TC clamp DN40-G½ outer (incl. seal)
04001208	TC clamp light PN7 DN25-40/1-1.5
04001209	TC clamp solid PN40 DN25-40/1-1.5
04001210	TC clamp high pressure PN80 DN25-40/1-1.5
09001844	Connection cable with M12 coupling 8-pin 2 m
06401995	Connection cable with M12 coupling 5-pin 2 m

7 Attachments

7.1 EU Declaration of Conformity



(Translation)

EU Declaration of Conformity

For the product described as follows

Product designation Programmable
Pressure transmitter / pressure switch

Type designation ME50 ... R####

It is hereby declared that it corresponds with the basic requirements specified in the following designated directives:

2014/30/EU	EMC Directive
2014/34/EU	ATEX Directive
2011/65/EU	RoHS Directive
(EU) 2015/863	Delegated Directive amending Annex II to Directive 2011/65/EU

The products were tested in compliance with the following standards.

DIN EN 61326-1:2013-07 EN 61326-1:2013	Electromagnetic compatibility (EMC) Electrical equipment for measurement, control and laboratory use - EMC requirements - Part 1: General requirements
DIN EN 61326-2-3:2013-07 EN 61326-2-3:2013	Electrical equipment for measurement, control and laboratory use - EMC requirements - Part 2-3: Particular requirements - Test configuration, operational conditions and performance criteria for transducers with integrated or remote signal conditioning
DIN EN IEC 60079-0:2019-09 EN IEC 60079-0:2018 Correction 1 IEC 60079-0:2017/COR1:2020	Explosive atmospheres (ATEX) Explosive atmospheres - Part 0: Equipment - General requirements
DIN EN 60079-15:2011-02 EN 60079-15:2010	Explosive atmospheres - Part 15: Equipment protection by type of protection "n"
DIN EN IEC 63000:2019-05 EN IEC 63000:2018	RoHS Directive (RoHS3) Technical documentation for the assessment of electrical and electronic products with respect to the restriction of hazardous substances

Also they were subjected to the conformity assessment procedure „Internal production control“.

Sole responsibility for the issue of this declaration of conformity in relation to fulfilment of the fundamental requirements and the production of the technical documents is with the manufacturer.

Manufacturer FISCHER Mess- und Regeltechnik GmbH
Bielefelder Str. 37a
32107 Bad Salzufflen, Germany
Tel. +49 (0)5222 974 0

Documentation representative Torsten Malischewski
General Manager R&D

The devices bear the following marking:

Ex II 3G Ex nA IIC T4 Gc

Bad Salzufflen
25 March 2022

G. Gödde
Managing director

09010259 · CE_EN_ME50_R · Rev. ST4-B · 03/22

1 / 1



Fig. 14: CE_EN_ME50_R

Notes

Notes



FISCHER Mess- und Regeltechnik GmbH

Bielefelder Str. 37a
D-32107 Bad Salzuflen

Tel. +49 5222 974-0

Fax +49 5222 7170

www.fischermesstechnik.de

info@fischermesstechnik.de