



Datasheet

DE27

Digital differential pressure transmitter
for gaseous media

09005602 • DB_EN_DE27 • Rev. ST4-F • 07/22

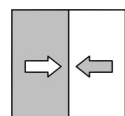

1 Product and functional description

1.1 Performance characteristics

Important characteristics

- Robust, resistant to overpressure and maintenance-free
- Signal output with the option of spreading and inverting the characteristic curve with any offset within the measuring range
- All parameters and measuring point protocols are configured with a Transmitter PC Interface EU03 (accessory)

Typical applications

- Monitoring of automatic roll filters
- Extraction systems etc.
- Draft measurement in chimneys
- Flow and control pressure measurements

Areas of Application

- Air-conditioning technology
- Ventilation technology
- Environmental technology

1.2 Equipment versions

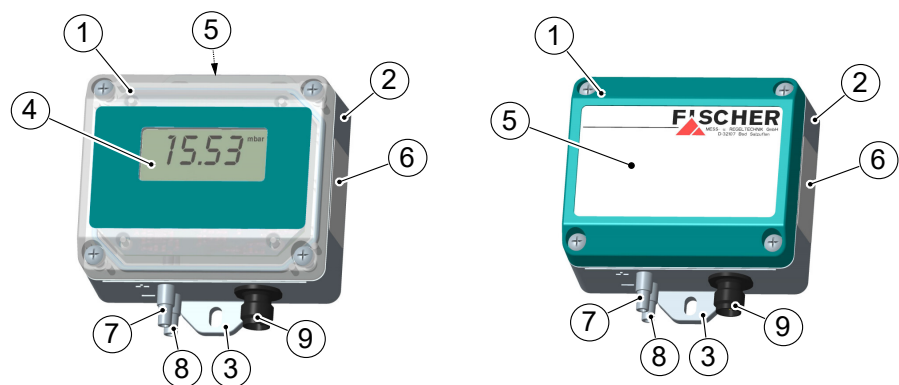

a) Model with measurement data display

b) Model without measurement data display

Fig. 1: Equipment versions

1	Casing lid	2	Lower part of casing
3	Fixing lug	4	LC display
5	Nameplate	6	Circuit diagram M12 plug
7	Process connection (+)	8	Process connection (-)
9	M12 plug		

1.3 Use as intended

The DE27 is a multi-functional differential pressure transmitter. It is suitable for measuring overpressure, under-pressure and differential pressure in dry and neutral gaseous media.

1.4 Function diagram

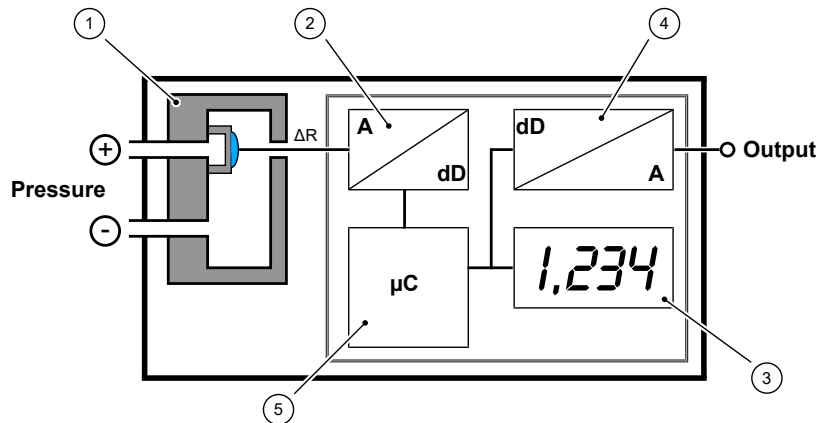

Fig. 2: Function diagram DE27

1	Sensor element	2	Signal converter
3	LC display	4	Analogue output
5	Micro-controller		

1.5 Design and mode of operation

The basis of this transmitter is a piezo-resistive sensor element. The pressures to be measured directly act on a silicon diaphragm equipped with piezo-resistive resistors. Changes in pressure generate proportional changes in resistance, which is evaluated by the device's electronics and transformed into signals on the optional display, and converted into an output signal.

The output signal, which is optionally available as a current or voltage signal ⁽¹⁾ can be dampened, spread and inverted. Configuration is realised via a Transmitter PC Interface (EU03) that is available as an accessory.

1.6 Socket assignment

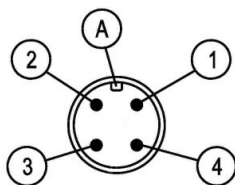

Fig. 3: M12 connector 4-pin

Pin	Signal name		Cable colour
1	Supply / output signal	+U _b /+Sig	brown
2	n.c.		white
3	Supply / output signal	-U _b /-Sig	blue
4	n.c.		black
A	Coding		

Table 1: 2 Conductor circuit

Pin	Signal name		Cable colour
1	Supply	+U _b	brown
2	n.c.		white
3	Supply / output signal	-U _b /-Sig	blue
4	Output signal	+Sig	black
A	Coding		

Table 2: 3 Conductor circuit

⁽¹⁾see order code

2 Technical data

2.1 General

Please also observe the order code here.

2.2 Input variables

In addition to the listed units the following units are also available: bar, kPa, psi, InWC and %.

Basic measuring range		Stat. operating pressure max.		Bursting pressure	
mbar	Pa	mbar	kPa	mbar	kPa
0 ... 4	0 ... 400	50	5	150	15
0 ... 6	0 ... 600	50	5	150	15
0 ... 10	0 ... 1000	100	10	300	30
0 ... 16	0 ... 1600	100	10	300	30
0 ... 25	0 ... 2500 ⁺⁾	250	25	750	75
0 ... 40	0 ... 4000 ⁺⁾	250	25	750	75
0 ... 60	0 ... 6000 ⁺⁾	500	50	750	75
0 ... 100	---	500	50	750	75
-2.5 ... +2.5	-250 ... +250	50	5	150	15
-4 ... +4	-400 ... +400	50	5	150	15
-6 ... +6	-600 ... +600	50	5	150	15
-10 ... +10	-1000 ... +1000	100	10	300	30
-16 ... +16	-1600 ... +1600	100	10	300	30
-25 ... +25	-2500 ... +2500 ⁺⁾	250	25	750	75
-40 ... +40	-4000 ... +4000 ⁺⁾	250	25	750	75
-60 ... +60	-6000 ... +6000 ⁺⁾	500	500	750	75

⁺⁾ Only available for 4-digit display resolution (-9999 ... +9999). The last digit in this case can be slightly unsettled.

2.3 Output parameters

Output signal	4 ... 20 mA	0 ... 10 V
Connection type	2-Wire	3-Wire
Load	$R_L \leq (U_b - 6V)/0.02 \text{ A}$	$U_b = 12 \dots 15V \quad R_L \geq 15 \text{ k}\Omega$ $U_b > 15 \text{ V} \quad R_L \geq 12 \text{ k}\Omega$

2.4 Measurement accuracy

	Measuring range	0...	4	6	10	16	25	40	60	100
Characteristic curve deviation °) ¹⁾	Max. %FS						2.5 (1.0)			
	Type %FS						1.5 (0.5)			
TK span ^{x)}	Max. %FS		1.0	1.0	0.3	0.3	0.3	0.3	0.3	0.3
	Type %FS		0.3	0.3	0.3	0.3	0.3	0.3	0.3	0.3
Tk zero-point ^{x)}	Max. %FS / 10K		1.0	1.0	0.4	0.4	0.4	0.4	0.4	0.4
	Type %FS / 10K		0.2	0.2	0.2	0.2	0.2	0.2	0.2	0.2

	Measuring range	± 2.5	± 4	± 6	± 10	± 16	± 25	± 40	± 60
Characteristic curve deviation °) ¹⁾	Max. %FS						2.5 (1.0)		
	Type %FS						1.5 (0.5)		
TK span ^{x)}	Max. %FS / 10K	1.0	0.5	0.3	0.3	0.3	0.3	0.3	0.3
	Type %FS / 10K	0.3	0.3	0.3	0.3	0.3	0.3	0.3	0.3
Tk zero-point ^{x)}	Max. %FS / 10K	1.0	0.5	0.4	0.4	0.4	0.4	0.4	0.4
	Type %FS / 10K	0.2	0.2	0.2	0.2	0.2	0.2	0.2	0.2

¹⁾ Characteristic curve deviation (non-linearity and hysteresis) at 25°C and rated voltage basic measuring range with linear characteristic curve, not spread

A smaller deviation can be realised in certain measuring ranges (values in brackets). Please contact our sales department in this case.

^{x)} In relation to the basic measuring range with a linear, not spread, characteristic curve.

2.5 Auxiliary energy

Characteristic value	2-Wire	3-Wire
Rated Voltage	24 V DC	24 V AC/DC
Admissible operating voltage U_b	6 ... 32 V DC	12 ... 32 V AC/DC
Power consumption	≤ 22 mA	≤ 15 mA

2.6 Application conditions

Permissible ambient temperature	-10 ... +70 °C
Admissible medium temperature	-10 ... +70 °C
Admissible storage temperature	-20 ... +70 °C
Enclosure protection class	IP65 acc. to DIN EN 60529
EMC	EN 61326-1:2013 EN 61326-2-3:2013
RoHS	EN 50581:2012

2.7 Display and operating interface

2.7.1 Measured Value Display

3½ digit LCD	-1999 ... +1999
4 digit LCD	-9999 ... +9999



NOTICE

4 digit LCD

In 4-digit display resolutions, the display resolution may be larger than the measuring resolution (approx. 3500 digits). This may cause an unsettled display.

2.7.2 Operating interface

The device does not have a keyboard; this means that the customer can only configure it using the Transmitter PC Interface EU03 (accessory).

Parameter	Value range
Attenuation	0.0 ... 100.0 s (jump response time 10 / 90 %)
Zero-point window	$\pm\frac{1}{3}$ basic measuring range ⁽⁰⁾
Unit	bar, mbar, Pa, kPa, psi, InWC, % ⁽¹⁾
Offset	$\pm\frac{1}{3}$ basic measuring range
Measuring range start/end	Within the basic measuring range ⁽²⁾
Measurement range characteristic curve	Linear, max. turn down 4:1, inverted, rooted, table
Free unit	-9999 ... +9999
Measuring range start/end	

⁽⁰⁾ This value defines the range around the zero-point in which the measured value is set to zero, e.g. for creep flow suppression.

⁽¹⁾ The unit '%' refers to the measuring range defined by the start of the measuring range (0%) and the end of the measuring range (100%).

⁽²⁾ This only impacts on the output signal. A falling characteristic curve is possible, if the start of the measuring range > end of the measuring range.

2.8 Construction design

Process connection Plug nipple for 6/4 mm or 8/6 mm hose

Materials	Housing	with display	without display
	Lower part of casing	Polyamide PA 6.6	Polyamide PA 6.6
Casing lid	Polycarbonate PC	Polycarbonate PC	Polyamide PA 6.6

Media-contacting material Silicon, PVC, aluminium, brass

Assembly Wall mounting

Dimensional drawing All dimensions in mm unless otherwise stated

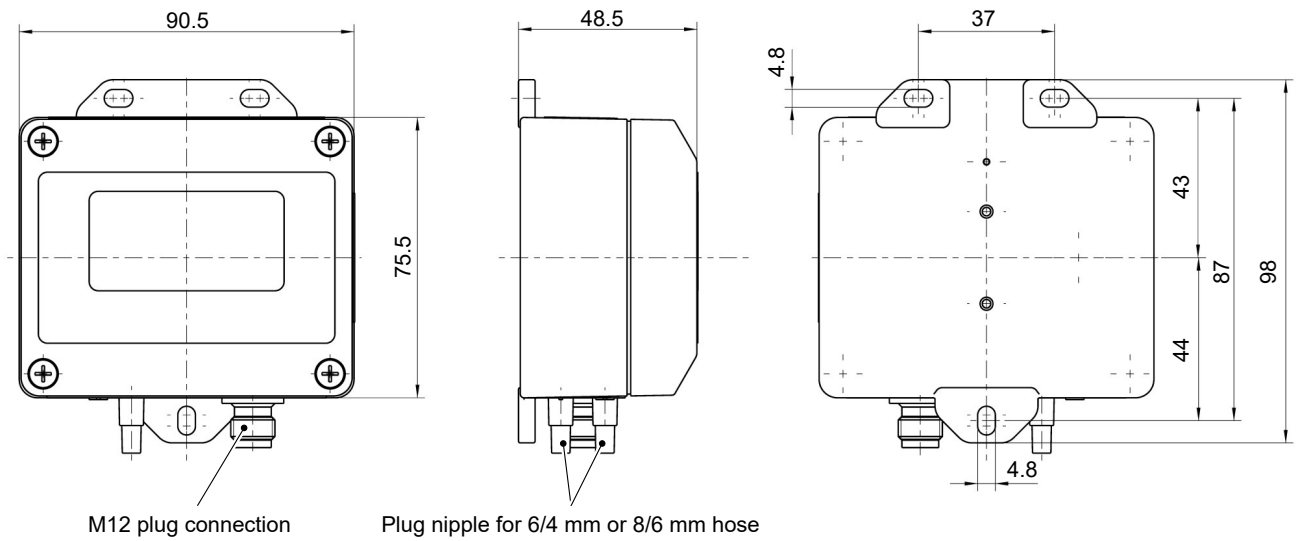
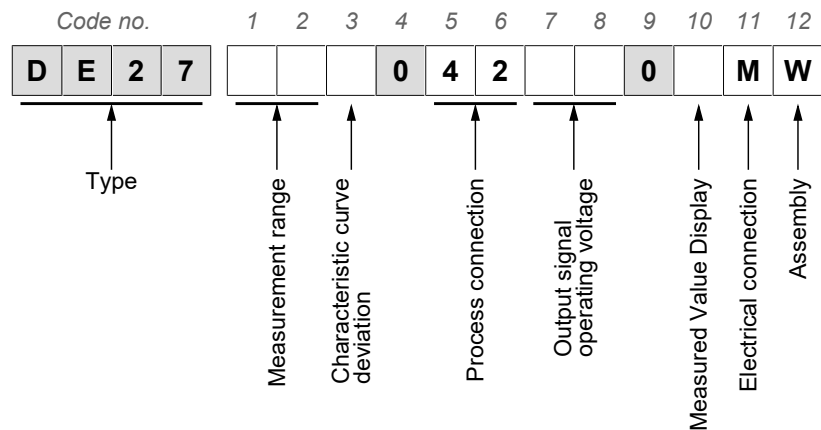

Fig. 4: Dimensional drawing

3 Order Codes



Measurement range

[1.2]	Measurement range	Static operating pressure
52	0 ... 4 mbar	50 mbar
53	0 ... 6 mbar	50 mbar
54	0 ... 10 mbar	100 mbar
55	0 ... 16 mbar	100 mbar
56	0 ... 25 mbar	250 mbar
57	0 ... 40 mbar	250 mbar
58	0 ... 60 mbar	500 mbar
59	0 ... 100 mbar	500 mbar
A6	-2.5 ... +2.5 mbar	50 mbar
A7	-4 ... +4 mbar	50 mbar
A8	-6 ... +6 mbar	50 mbar
A9	-10 ... +10 mbar	100 mbar
B1	-16 ... +16 mbar	100 mbar
B2	-25 ... +25 mbar	250 mbar
C5	-40 ... +40 mbar	250 mbar
B3	-60 ... +60 mbar	500 mbar
D7	0 ... 400 Pa	5 kPa
D8	0 ... 600 Pa	5 kPa
D9	0 ... 1000 Pa	10 kPa
E1	0 ... 1600 Pa	10 kPa
E2	0 ... 2500 Pa	25 kPa
E3	0 ... 4000 Pa	25 kPa
E4	0 ... 6000 Pa	50 kPa
N3	0 ... 2.5 kPa	25 kPa
N4	0 ... 4.0 kPa	25 kPa

Characteristic curve deviation (relative pressure)

[3]	
K	Characteristic curve deviation 2.5%
M	Characteristic curve deviation 1.0% ⁽⁰⁾

⁽⁰⁾ A characteristic curve deviation of 1% cannot be realised for all measuring ranges. Please contact our sales department in this case.

Process connection	[5.6]		
	42	Plug nipple for 6/4 mm or 8/6 mm hose	
Output signal operating voltage	[7.8] Outlet		Operating voltage
	BP	4 ... 20 mA DC	2-Wire 24v DC
	CK	0 ... 10 V DC	3-Wire 24 V AC/DC
Measured value display	[10]		
	0	No measured value display	
	1	3½-digit measured value display	
	A	4-digit measured value display	
Electrical connection	[11]		
	M	M12 plug connection	
Assembly	[12]		
	W	Wall mounting	

3.1 Accessories

Order no.	length	No. of Poles	Designation	Usage
06401993	2m	4-pin	Connection cable with M12 connector	For supply and output signal
06401994	5m			
06401563	7m			
06401572	10m			
06401566	15m			

Transmitter PC Interface

Order no.	
EU03 F300	Transmitter PC Interface incl. PC software for remote configuration of 3-wire transmitters
EU03 F200	Transmitter PC Interface incl. PC software for remote configuration of 2-wire transmitters

Connection set

Order no.	Designation	hose	length
04005129	Plastic connection set	2 x 6/4 mm	1m
04005148	Plastic connection set	2 x 6/4 mm	2.5 m
04005163	Plastic connection set	2 x 6/4 mm	5m
04005216	Plastic connection set	2 x 6/4 mm	10m
04005217	Plastic connection set	2 x 8/6 mm	1m
04005218	Plastic connection set	2 x 8/6 mm	5m

3.2 Information about the document

This document contains all technical data about the device. Great care was taken when compiling the texts and illustrations. nevertheless, errors cannot be ruled out.

Subject to technical amendments.

Notes

Notes



FISCHER Mess- und Regeltechnik GmbH

Bielefelder Str. 37a
D-32107 Bad Salzuflen

Tel. +49 5222 974-0

Fax +49 5222 7170

www.fischermesstechnik.de
info@fischermesstechnik.de