

## Datasheet

DE58

**Digital Differential Pressure Transmitter / Switch**  
**with 3½ digit LED display**



Display and switching device for measurement of differential pressures with mainly neutral liquid and gaseous media.

Areas of Application:

- Filling level measuring technology for technical gases

### Design and Mode of Operation

The device is based on a robust and durable diaphragm measuring unit that is suitable for measuring overpressure, underpressure and differential pressure. The pressures to be compared have an effect on a spring mounted measuring diaphragm. In case of equal pressure, the measuring diaphragm is in its idle state. In case of pressure difference, the force acting on the measuring diaphragm causes it to be moved towards the side of the lower pressure until the spring forces compensate this force. This movement is transferred via a tappet into the core of the inductive displacement sensor. The linear movement of the core is proportional to the applied differential pressure. The electronics integrated into the device evaluate this movement and transform it into signals on the display, switch contacts and an optional output signal.

### Function Diagram

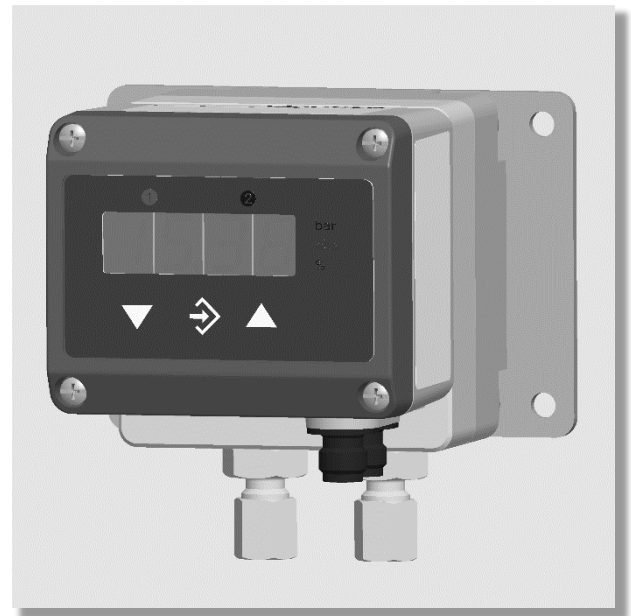
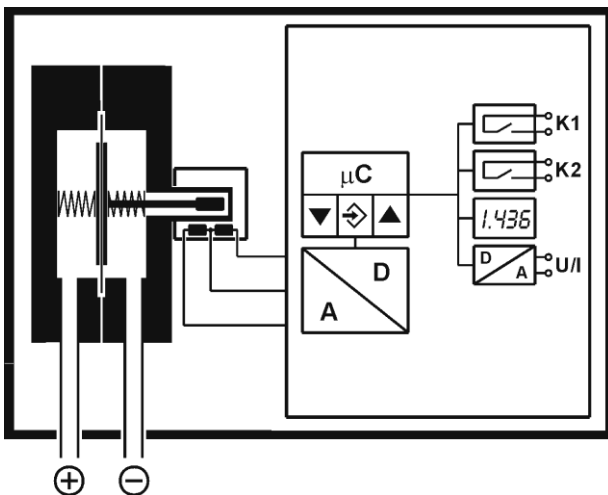

### Main Features

- Robust and resistant to overpressure
- Maintenance-free through wear-free inductive pickup
- Switchable pressure units
- Optional signal output with possibility of characteristic curve spread and reversal with any offset
- Characteristic curve implementation via table with max. 30 measuring points
- Complete adjustment of all parameters and measuring point protocol possible through optional PC adaptor EU03

### Typical applications

- Filling level monitoring of tank containers for liquefied technical gases (N<sub>2</sub>, O<sub>2</sub>, Ar and CO<sub>2</sub>).
- Filling level monitoring of mini tank systems

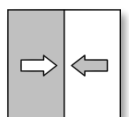

### Technical specifications

Measuring range	mbar	0-160	0-250	0-400	0-600
Max. static operating pressure	bar	16 bar			
Straight line error (max.)°	%FS	2.5 %			
Straight line error (typ.)°	%FS	0.8 %			
TC span (max.)°°	%FS/10K	0.8 %		0.4 %	
TC span (typ.)°°	%FS/10K	0.2 %			
TC zero point (max.)°°	%FS/10K	0.8 %		0.5 %	
TC zero point (typ.)°°	%FS/10K	0.2 %			

° : Straight line error = nonlinearity + hysteresis; at 25°C; pressure within specified range (characteristic linear, not spreaded)

°° : Pressure within specified range (characteristic linear, not spreaded); compensated temperature range 0 to 60°C

Operating temp. (ambient)	-20 ... 70°C
Operating temp. (media)	-20 ... 70°C
Storage temperature	-30 ... 70°C
Static operating pressure	(see table)
Overload capacity	single sided overpressure proof up to the rating of the measuring system; (+) and (-) side, vacuum proof
Protection class (housing)	IP 65 per DIN EN 60529
<b>Electrical</b>	
Nominal supply voltage	24 V DC/AC
Operating supply voltage	12 ... 32 V DC/AC
Output signal	0 ... 20 mA, 4 ... 20 mA, 0 ... 10 V (3-wire)
Output signal load	For output current $R_L \leq (U_B - 4 V) / 0.02 A$ ( $U_B \leq 26V$ ), else $R_L \leq 1100 \Omega$ For output voltage $R_L \geq 2 K\Omega$ ( $U_B \geq 15 V$ ), $R_L \geq 10 K\Omega$ ( $U_B = 12 ... 15V$ )
Power consumption	Approx. 2 W/VA
Switching contacts	2 sets of programmable voltage free relay contacts: NO or NC $U_{max} = 32 V DC/AC$ , $I_{max} = 2 A$ , $P_{max} = 64 W/VA$ Optional, instead of relay outputs: 2 programmable voltage free MOSFET switch outputs; NO/NC $U = 3 ... 32 V DC/AC$ , $I_{max} = 0.25 A$ , $P_{max} = 8 W/VA$ , $R_{ON} \leq 4 \Omega$
Display	3½ digit LED
<b>Connections</b>	
Electrical connections	Two round-shell multi-pin connector sockets (M12, male) Connector 1: 5-pin: power input and analog signal output Connector 2: 4-pin: relay contacts / solid-state switch outputs
Pressure connections	G 1/4 female threads with optional cutting ring fittings for 6 or 8 mm tube
<b>Materials, Mounting</b>	
Materials, housing	Polyamide PA 6.6
Materials, media contact	Aluminium, VITON®, EPDM
Mounting	Wall mountable using adaptor plate

Connector 1: Supply input and Signal output

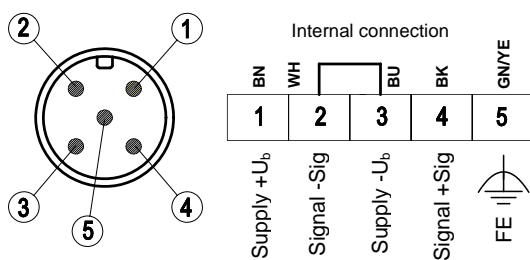

Connector 2: Switch outputs

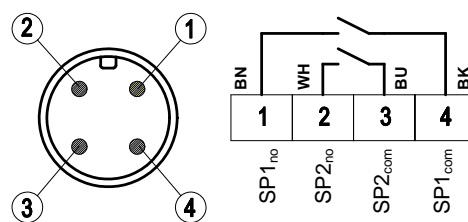

## Programming

Via membrane key-switches or by using PC-programming interface (accessory), programming mode can be password protected.

Settings:	
Input filtering	0.0 ... 100.0 secs (10 / 90% step response time) for signal output, display separated
Switch output ① ②	activation point, de-activation point, response time delay (0.0 ... 100.0 secs), logic (N/O or N/C)
Measurement unit selection	mbar / Pa / „free unit“ start value, end value and decimal place for „free unit“
Zero suppression	0 ... 1/3 of main measurement range (1)
Output signal start / end value	can be set at any point of measuring range (2)
Zero pressure calibration	± 1/3 of main measurement range (3)
Output characteristic	Linear, square rooted, horizontal cylindr. tank, table (3...30 entries)
Password range	001 ... 999 (000 = password protection disabled)

(1) Measured value deviations symmetric about zero, are set to zero. Used for zero drift suppression.

(2) Maximum effective turn-down ratio = 4:1. Only the output signal is affected. Transfer function is inverted if start value > end value.

(3) Zero calibration setting may change with mounting orientation.

## Dimensioned drawings

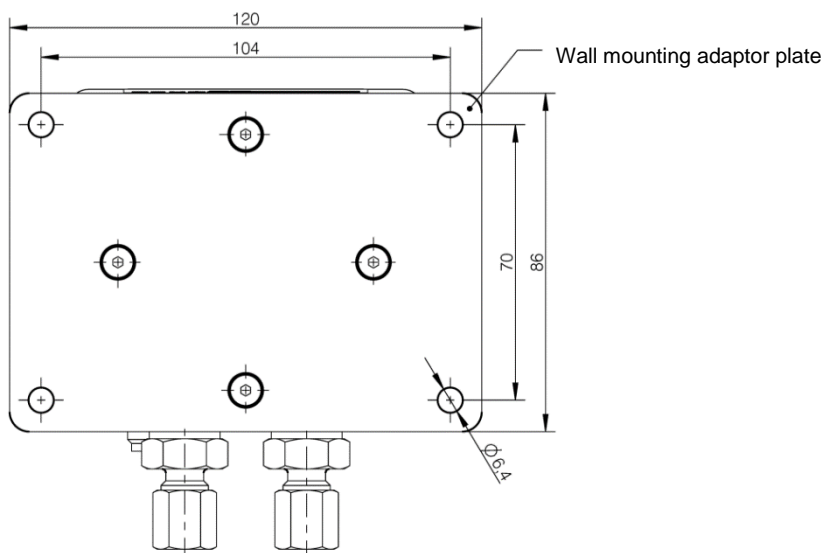
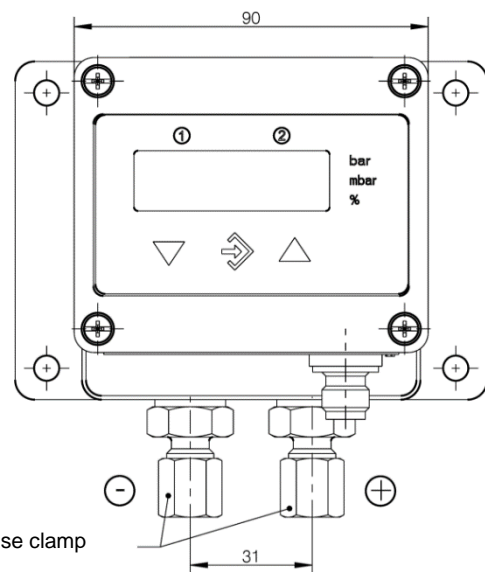
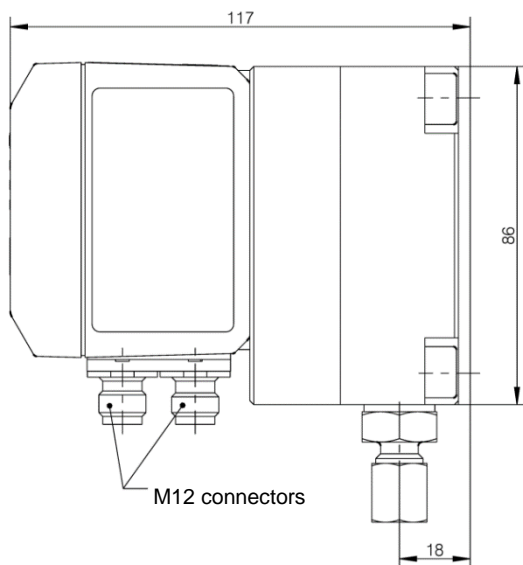

**Ordering code**

**Digital Differential Pressure Transmitter / Switch**

Type DE58

		A	A				K	0		M	W
--	--	---	---	--	--	--	---	---	--	---	---

**Measuring range**

0 ... 160mbar .....	>	6	0
0 ... 250mbar .....	>	8	2
0 ... 400mbar .....	>	8	3
0 ... 600mbar .....	>	C	1

**Diaphragm, Gaskets**

EPDM / FKM .....	>	A
------------------	---	---

**Pressure Chamber**

Aluminium, black anodized .....	>	A
---------------------------------	---	---

**Pressure connections**

G 1/4 female thread .....	>	0	1
Connector with male thread G1/4 B Brass .....	>	0	6
Cutting ring connection of 1.4571 for 6 mm tube .....	>	2	4
Cutting ring connection of 1.4571 for 8 mm tube .....	>	2	5
Cutting ring connection of brass for 6 mm tube .....	>	2	8
Cutting ring connection of brass for 8 mm tube .....	>	2	9

**Electrical Signal Output**

Without output signal .....	>	0
0 - 20 mA 3-wire (STANDARD) .....	>	A
0 - 10 V DC 3-wire (STANDARD) .....	>	C
4 - 20 mA 3-wire (STANDARD) .....	>	P

**Power Supply**

24 V DC/AC (12 - 32 V DC/AC) .....	>	K
------------------------------------	---	---

**Measuring Unit**

Standard Pressure Units .....	>	0
-------------------------------	---	---

**Display / Switching Function**

3½ digit LED display; 2 relay contacts .....	>	3
3½ digit LED display; 2 solid-state switch outputs .....	>	6

**Electrical connections**

M12 roundshell multi-pin connectors .....	>	M
-------------------------------------------	---	---

**Mounting**

Wall Mounting .....	>	W
---------------------	---	---

