



IEC 61508  
**SIL**



DIN 4754



DNVGL.COM/AF



RoHS III  
COMPLIANT



## Datasheet

### DS21

Differential pressure measuring and switching device

Flow guard in heat transfer oil systems in compliance with DIN 4754-2 and hot water systems according to VdTÜV Information sheet "Flow 100"

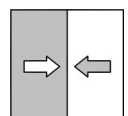
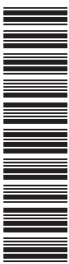

# 1 Product and functional description

## 1.1 Use as intended

The unit is exclusively designed for the purpose defined by the manufacturer in the data sheet or operating instructions.

### Differential pressure measuring and switching device

The DS21 is a measuring and switch unit for measuring differential pressure under difficult measuring conditions such as: pressure surges, vibrations, frequent switching and high demands on the switching output. Please contact the manufacturer before using this unit with dirty or aggressive media because the unit needs to be adapted in terms of the parts that come into contact with the media.

**NOTICE! With regard to the Pressure Equipment Directive, the device is designed for a static load of up to 25 bar and a media temperature of up to 85 °C.**

### Flow assurance

The units in this series are used as flow guards in heat transfer oil systems in compliance with DIN 4754-2 and hot water systems in compliance with VdTÜV information sheet 'Flow 100'. The flow guards comprise a differential pressure transducer, e.g. a measuring orifice, the differential pressure measuring and switch unit and shut-off fittings. The respective installation instructions must be observed for this application case. All units of the series DS21 satisfy these requirements.



## NOTICE

The type tests in compliance with DIN 4754-2 and VdTÜV information sheet "Flow 100" only apply in conjunction with a differential pressure transducer, not for a differential pressure measuring and switching device alone.

The successful type test of the series DS21 was confirmed by means of the following test symbols:

- for flow guards in compliance with DIN 4754-2 :  
DIN CERTCO registration number 10S001
- according to VdTÜV Information sheet "Flow 100" :  
Part code TÜV . SW/SB . 15 – 020

### Use in safety-related systems (SIL)

The unit can be used in safety-related systems.

For use in safety-related systems according to 'Functional Safety' (SIL), the correct function of the safety function must be proven. The necessary key figures, safety instructions, assembly and maintenance instructions can be found in the Safety Manual (SHB).

The safety manual is available for download at [www.fischermesstechnik.de](http://www.fischermesstechnik.de).



IEC 61508 SIL

## 1.2 Equipment versions

The DS21 can be supplied with the following different pressure chambers:

- Aluminium
- Stainless steel 1.4305

The aluminium pressure chambers can also be supplied with a HART COAT® coating. The following shows the various unit versions. On the left-hand side are casings with hoods (IP 55) and on the right-hand side casings with bayonet rings (IP 65).



### NOTICE

#### Installation of front panel

Please note that the switch points of devices with bayonet rings need to be set before mounting the front control panel. When installed, the unit can no longer be opened.

Please see the order code [▶ 14] for the process connection options.

#### 1.2.1 Pressure chamber in aluminium

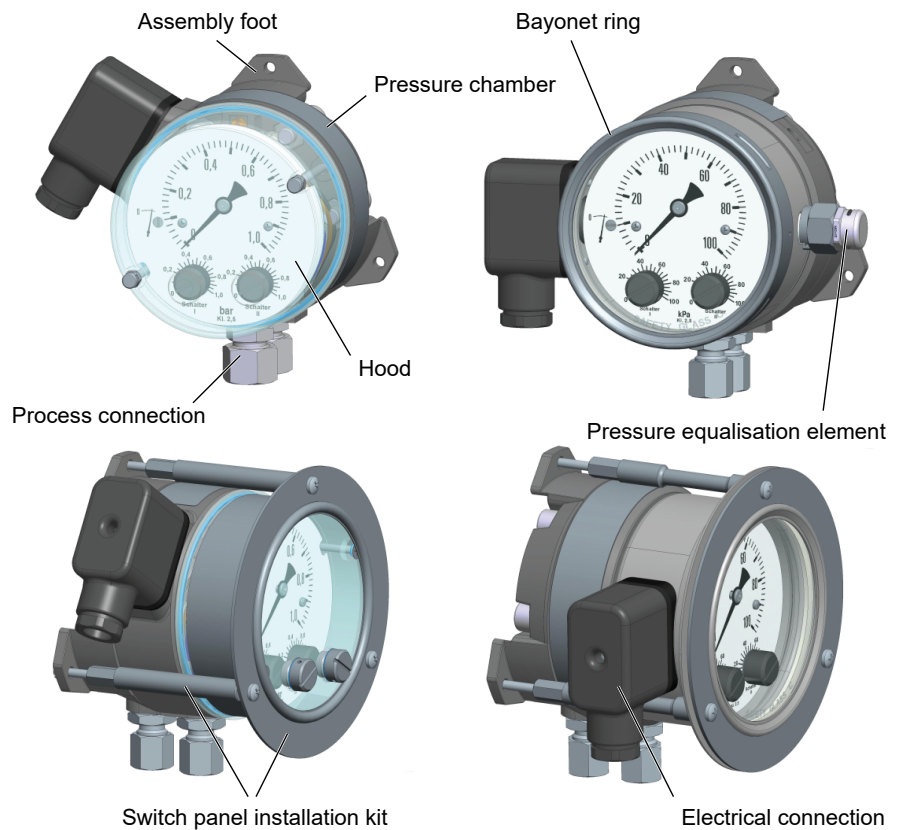

Fig. 1: DS21\_Pressure chamber in aluminium [Standard]

### 1.2.2 Pressure chamber in stainless steel

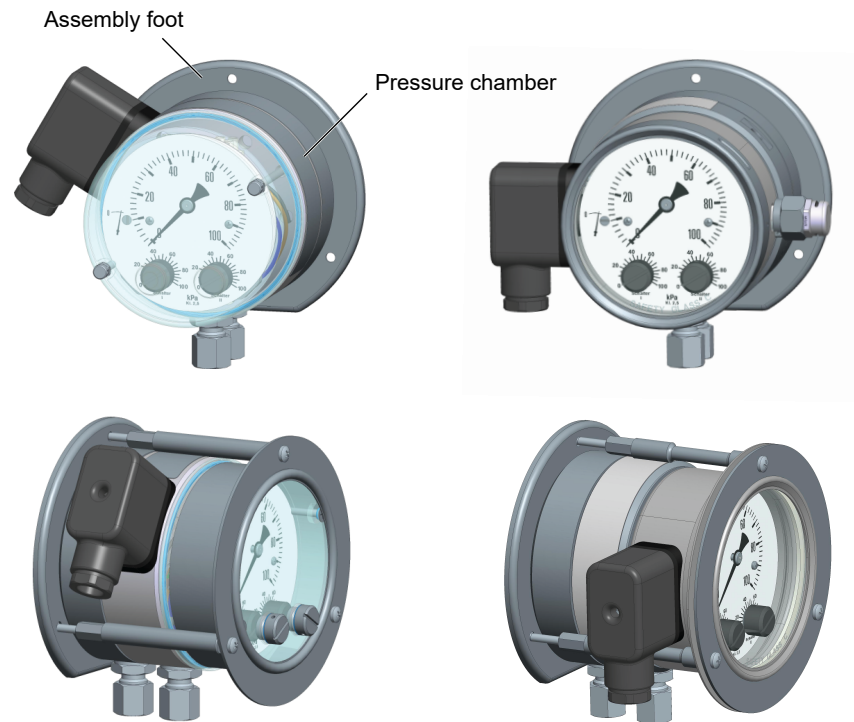
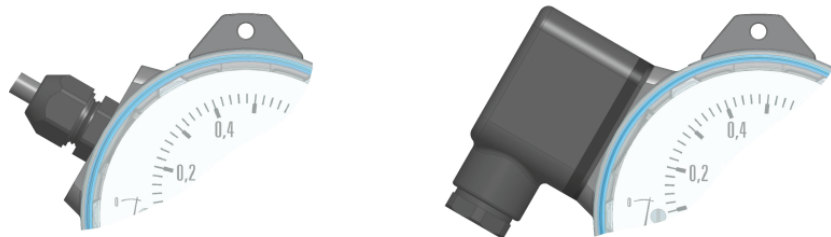

Fig. 2: DS21\_Pressure chamber in stainless steel [Standard]

### 1.2.3 Electro connection variants

All pressure chamber types are available optionally with a permanently wired number cable, a cable connection socket or a cable connector. The cable connector has the same dimensions as the cable socket.

DNV-GL models are an exception. These are only supplied with a cable socket including a 3 m long connection cable. The associated wiring diagrams are shown on the type plate and in the section 'Installation and assembly'.



Numbered cables

Cable connection socket

Fig. 3: DS21\_EL-connection variants [Standard]

### 1.3 Function diagram

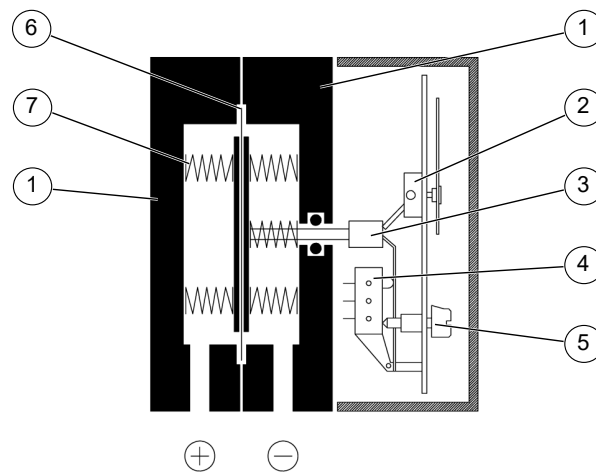

Fig. 4: DS21 Function diagram [Standard]

1	Pressure chamber	2	Motion train
3	Tappet	4	Micro-switch
5	Switch point setting	6	Measuring diaphragm
7	Measuring springs		

### 1.4 Design and mode of operation

The basis for this measurement and switch unit is a sturdy non-sensitive diaphragm measuring unit that is suitable for measuring differential pressure, and over and under-pressure. The unit uses the same measuring principle for all three measuring applications.

In the idle position, the spring forces are equalised on both sides of the measuring diaphragm. The pressure that is to be measured or the differential pressure creates a one-sided force on the measuring diaphragm that moves the diaphragm system against the measuring range springs until the spring forces are equalised. In the case of overload, the measuring diaphragm is supported by metallic contact surfaces.

A central tappet transfers the movement of the diaphragm system onto the display mechanism and, at the same time, onto the actuation elements of the micro-switches. The switch points are set via the setting screws and referenc value scale.

### 1.5 Market access

The approval or type examination by a notified body is valid throughout the EU. The acceptance of the certificates issued for export to third countries must be checked in each individual case.

#### UK market (UKCA)

With the 'BREXIT', EU testing institutes lose their validity as notified bodies in the UK. The certificates issued in the EU will subsequently no longer be recognised.

## 2 Technical data

Please also observe the order code here.

### 2.1 Input variables

**Measuring variable**

Differential, over and under-pressure for gaseous and fluid media.

**Measurement range**

Measurement range	Allowed static operating pressure
0 ... 250 mbar	6 bar
0 ... 400 mbar	6 bar
0 ... 0.6 bar	10 bar
0 ... 1 bar	16 bar
0...1.6 bar	16 bar
0...2.5 bar	16 bar
0 ... 4 bar	16 bar
0 ... 6 bar	16 bar

**Rated pressure of the measuring system**

25 bar

**Max. pressure load**

Over-pressure-proof on one side up to rated pressure of the measuring system, (+) and (-) sides, under-pressure-proof

### 2.2 Output parameters

**Switching outputs**

1 or 2 micro-switches with 1-pin changeover contact.

**Switch point setting**

After opening the casing using the setting screw and reference value scale. Smallest settable value approx. 5% of the end value of the measuring range.

**Reproducibility**

The reproducibility of the switch-point setting corresponds to the measuring precision.

**Switch hysteresis**

approx. 2.5% of the upper range value

**Load data/contact**

		AC	DC
Max. switching voltage	$U_{\max}$	250V	30V
Max. switching current	$I_{\max}$	5A	0.4A
max. switching output	$P_{\max}$	250 VA	10 W

### 2.3 Measured Value Display

**Anzeige**

Indicator with measurement scale

**Measurement accuracy**

$\pm 2.5\%$  of the upper range value

## 2.4 Electrical connection

- Cable socket  
screw terminal up to 1.5 mm<sup>2</sup> with wire protection  
Contact material Ms gold-flashed  
Cable screw connection M20 x 1.5
- Cable connector  
screw terminal up to 1.5 mm<sup>2</sup> with wire protection  
Contact material Ms nickel-plated  
Cable screw connection M20 x 1.5
- Number cable  
4 x 0.75 mm<sup>2</sup> YSLY-JZ  
strand end with clip, wire ID 1,2,3, green/yellow

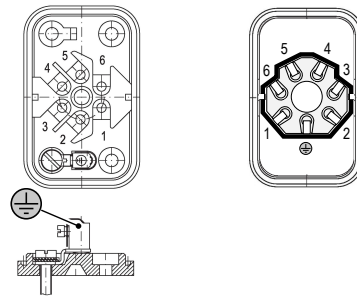

Fig. 5: Cable socket / plug

No	Contact	Switch	
1	Make contact	NO	
2	Break contact	NC	
3	Joint	COM	
4	Joint	COM	
5	Make contact	NO	
6	Break contact	NC	
⊕	Ground connection		

### GL version

In models with one switch, a cable (**0.6/1KV 4Gx1.5**) with the following color code is connected:

Ter- minal	Wire ID
1	grey
2	brown
3	black
⊕	green/yellow

In models with two switches, a cable (**0.6/1KV 7Gx1.5**) with numbers for identifying the wires must be connected. The numbers of the cable correspond to the terminal numbers of the cable socket.

## 2.5 Application conditions

<b>Ambient conditions</b>	Allowed ambient temperatures	-10 °C ... +70 °C
	Allowed temperature of the medium	-10 °C ... +85 °C <sup>*)</sup>
	Enclosure protection class (depending on model)	IP 55 or IP 65 in compliance with DIN EN 60529

<sup>\*)</sup> The temperature in the unit may not exceed +70 °C.

<b>EC Declaration of conformity</b>	Low-Voltage Directive	2014/35/EU
	Pressurised Vessel Directive	2014/68/EU
	RoHS Directive	2011/65/EU (EU) 2015/863

<b>Certificates</b>	Type testing (Module B)	0045/202/1403/Z/01262/22/D/001(00)
	Quality assurance system (Module D)	0045/202/1404/Z/00289/21/D/001(01)
	EAC Declaration	EA3C N RU Д-DE.PA01.B43065/22
	DIN CERTCO	10S001
	VdTÜV	TÜV.SW/SB.20-020
	DNV GL	TAA00002BW
	SIL 2 <sup>**)</sup>	44 799 13759902

<sup>\*\*)</sup> Only for devices with the order code for SIL (optional information).

## 2.6 Construction design

<b>Process connection</b>	Inner thread G $\frac{1}{4}$
	Cutting ring screw connection in steel for 6, 8, 10, 12 mm pipe
	Cutting ring screw connection in stainless steel 1.4571 for 6, 8, 10, 12 mm pipe
<b>Measuring system</b>	Pressure spring measuring diaphragm system
<b>Weight</b>	Pressure chamber in aluminium: approx. 1.2 kg Pressure chamber in CrNi steel: approx. 3.5 kg

### 2.6.1 Materials

<b>Pressure chamber</b>	Aluminium Gk-AISi10Mg, painted black
	Aluminium Gk-AISi10MG with HART-COAT <sup>®</sup> Surface protection CrNi steel 1.4305
<b>Measuring diaphragm</b>	Fabric-reinforced VITON <sup>®</sup>
<b>Gaskets</b>	VITON <sup>®</sup>
<b>Inner parts in contact with the medium</b>	CrNi-steel 1.4310, 1.4305
<b>Hood</b>	Polycarbonate (PC) Makrolon <sup>®</sup>
<b>Bayonet ring</b>	CrNi-Steel 1.4305
<b>Front pane</b>	Safety laminated glass

### 2.6.2 Assembly

Wall mounting  
Mounting the control panel



## 2.7 Dimensional drawings

(All dimensions in mm unless otherwise stated)

### 2.7.1 Pressure chamber in aluminium

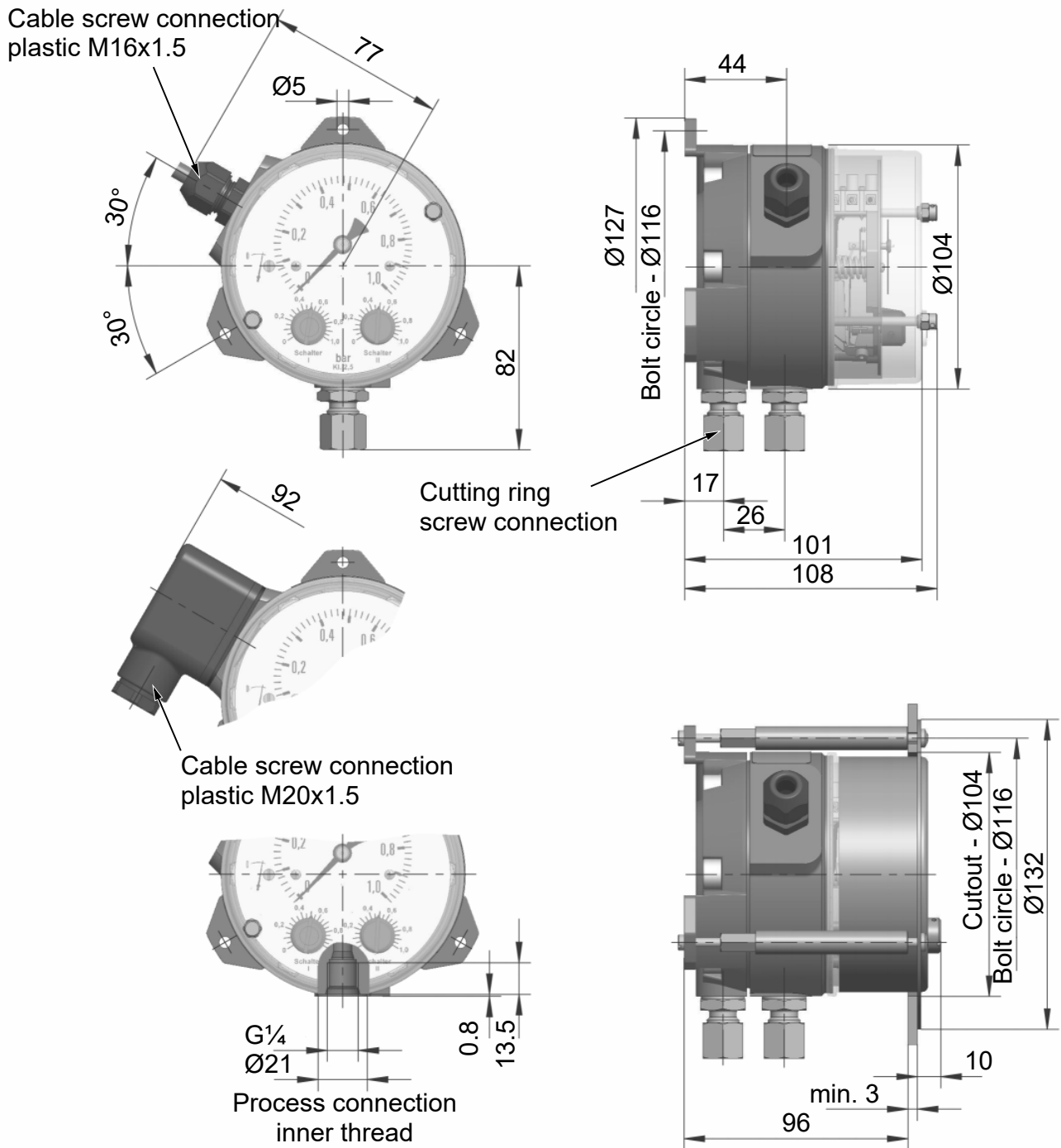

Fig. 6: Pressure chamber in aluminium (IP55)

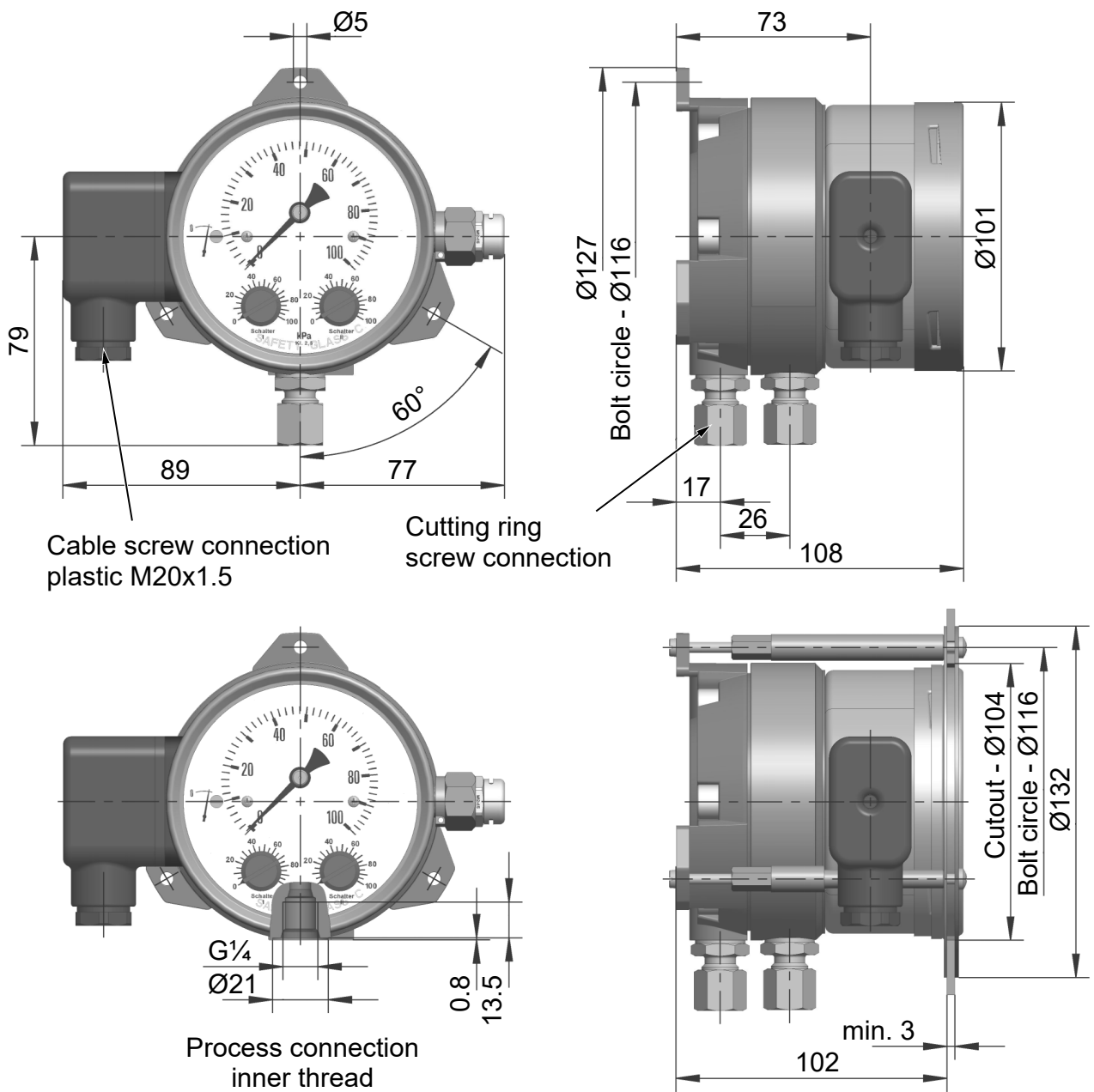

Fig. 7: Pressure chamber in aluminium (IP65)

2.7.2 Pressure chamber in stainless steel

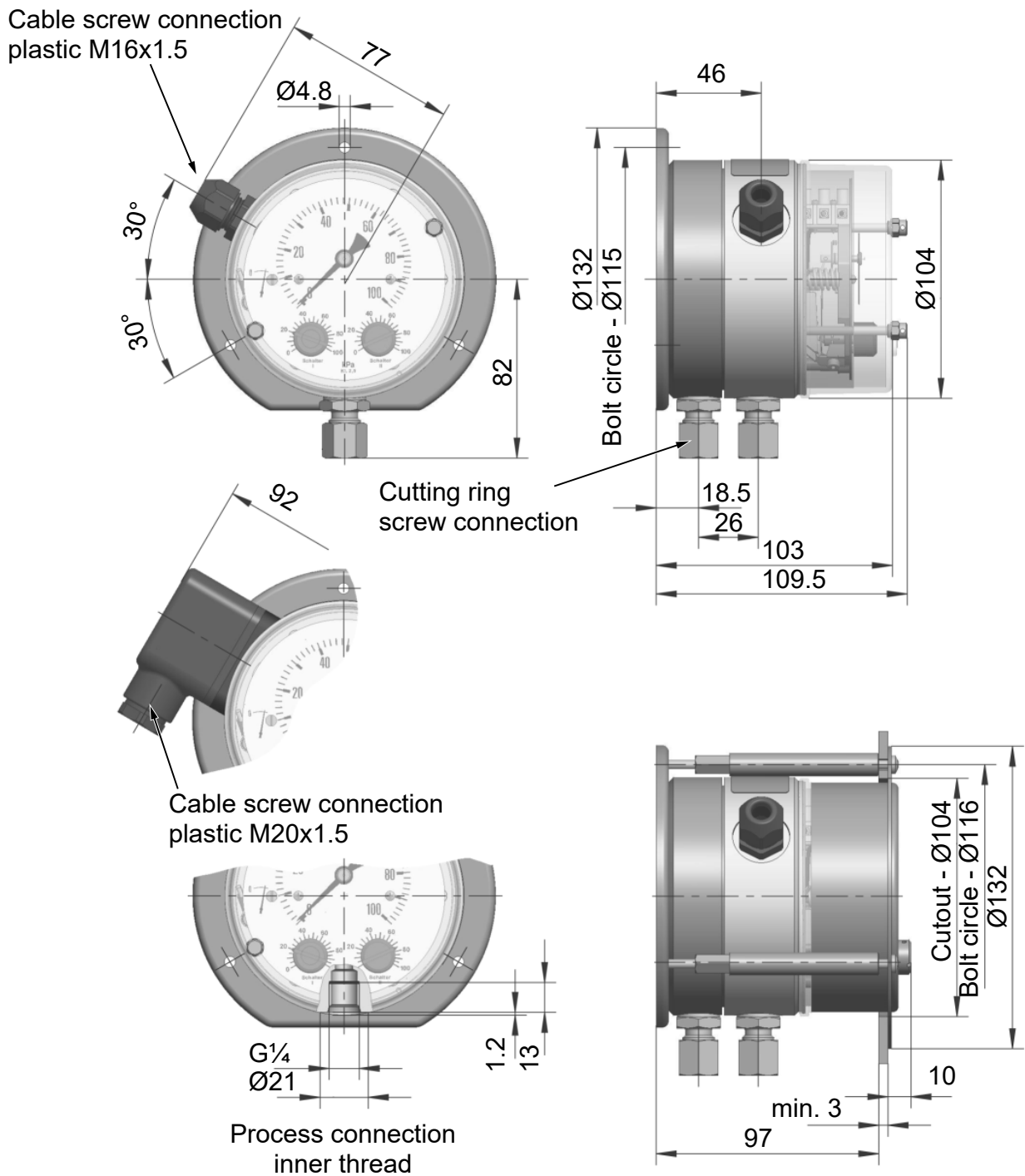

Fig. 8: Pressure chamber in VA (IP55)

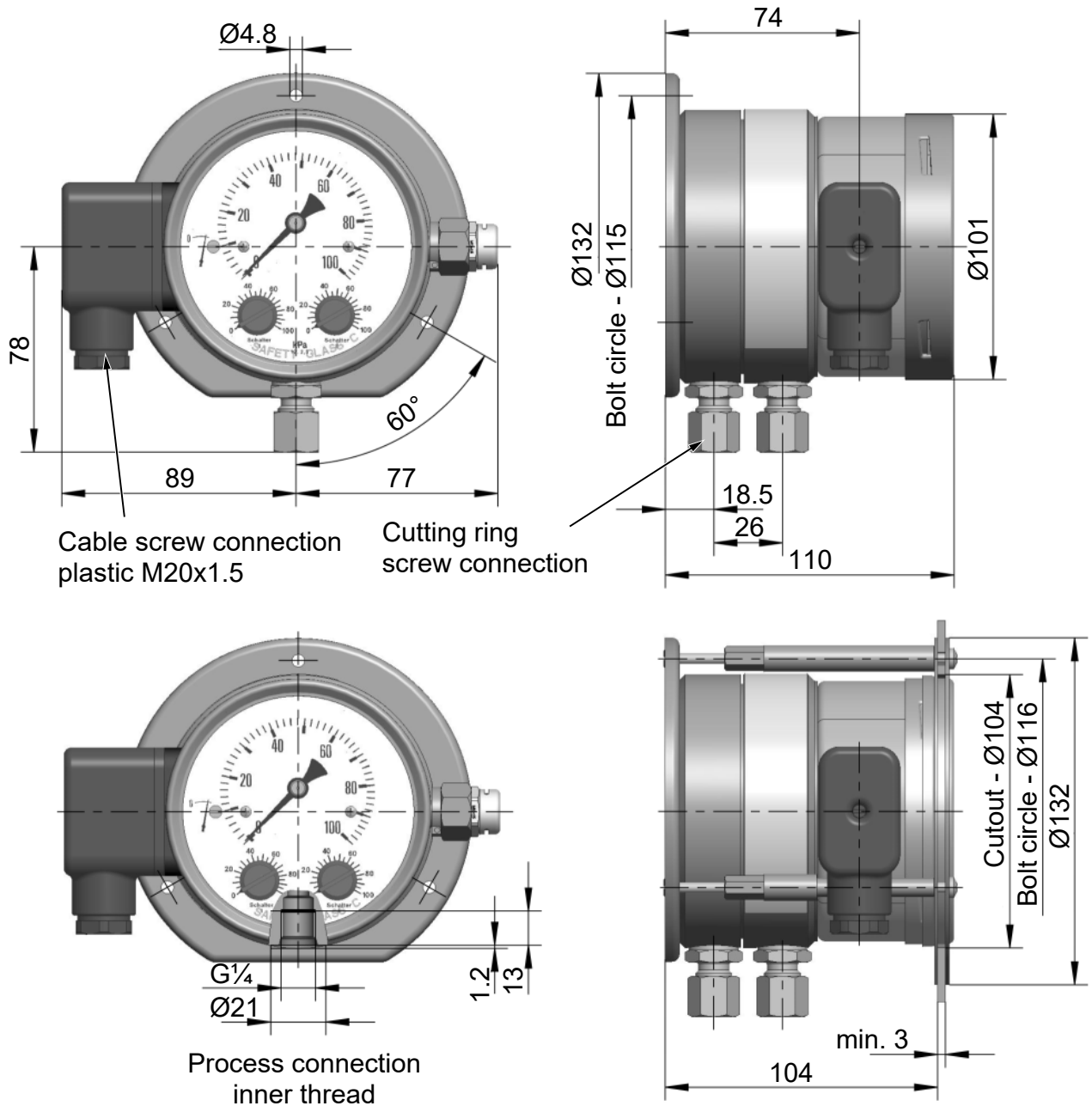

Fig. 9: Pressure chamber in VA (IP65)

### 2.7.3 Installation of front panel

The cutout required to mount the front control panel is the same for all models.

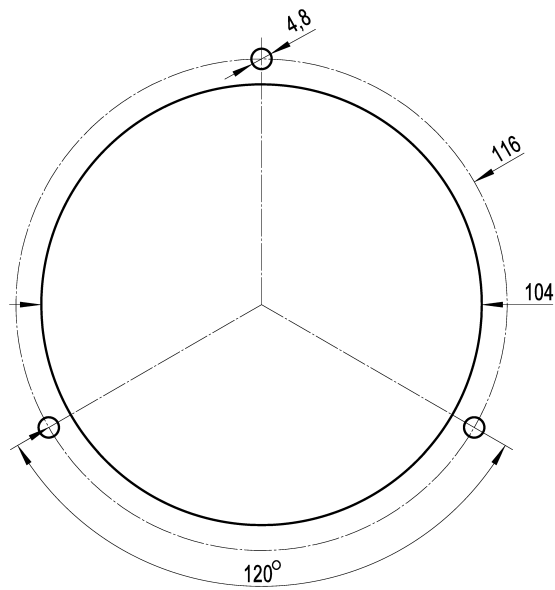
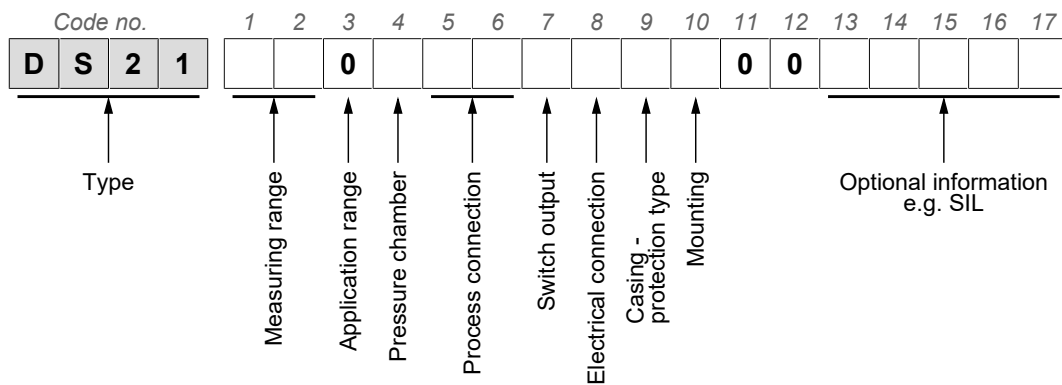

Fig. 10: Front panel cutout

### 3 Order Codes



#### Measuring range

[1.2]	← Code no.	Allowed static pressure
82	0 ... 250 mbar	6 bar
83	0 ... 400 mbar	6 bar
01	0 ... 0.6 bar	10 bar
02	0 ... 1 bar	16 bar
03	0 ... 1.6 bar	16 bar
04	0 ... 2.5 bar	16 bar
05	0 ... 4 bar	16 bar
06	0 ... 6 bar	16 bar

#### Application scope

[3]	← Code no.
0	Thermal oil DIN 4754-2 / Hot water Flow 100

#### Pressure chamber

[4]	← ? Code no.
A	Aluminium
D	Aluminium with HART COAT® coating
W	Stainless steel 1.4305

#### Process connection

[5.6]	← Code no.
01	Inner thread G 1/4
<b>Cutting ring screw connections made of steel</b>	
20	for 6 mm tube
21	for 8 mm tube
22	for 10 mm tube
23	for 12 mm tube
<b>Cutting ring screw connections made of stainless steel 1.4571</b>	
24	for 6 mm tube
25	for 8 mm tube
26	for 10 mm tube
27	for 12 mm tube

#### Switch output

[7]	← Code no.
A	1 micro-switch (can be configured)
B	2 micro-switch (can be configured)

<b>Electrical connection</b>	<b>[8]</b>	← <b>Code no.</b>
		Numbered cable, permanently wired
	<b>1</b>	1 m long
	<b>2</b>	2.5 m long
	<b>5</b>	5 m long
	<b>K</b>	Cable connection socket
	<b>Z</b>	DNV-GL version with 3 m connection cable
	<b>W</b>	Cable plug
<b>Casing protection class</b>	<b>[9]</b>	← <b>Code no.</b>
	<b>0</b>	IP55
	<b>P</b>	IP 65 (only with cable socket or cable connector)
<b>Assembly</b>	<b>[10]</b>	← <b>Code no.</b>
	<b>T</b>	Front panel mounting
	<b>W</b>	Wall mounting
<b>Optional information</b>	<b>[13-17]</b>	← <b>Code no.</b>
	<b>#####</b>	Code for special models e.g. SIL The code is generated as agreed with our sales team.



**FISCHER Mess- und Regeltechnik GmbH**

Bielefelder Str. 37a  
D-32107 Bad Salzuflen

Tel. +49 5222 974-0

Fax +49 5222 7170

[www.fischermesstechnik.de](http://www.fischermesstechnik.de)  
[info@fischermesstechnik.de](mailto:info@fischermesstechnik.de)