



Measurement technology for heating,
ventilation and air conditioning (HVAC) systems

Building Technology

- ▲ Improvement of the CO₂ balance for buildings
- ▲ Use controlled ventilation systems

Keyword Energy Efficiency

The optimization of HVAC systems is gaining in importance. This applies to both new and already existing installations. The growing awareness of environmental issues is also reflected in the requirements to products and processes. In this conjunction, for example, the greenhouse effect and its impact are being examined and evaluated within the framework of so-called ecological balances (ISO 14040 and 14044).

In addition to these overarching aspects the amended Energy Saving Ordinance (EnEV 2014) has been in force since May 2014. Its target is to help save energy in the building sector and secure the energy policy objectives of their Government.

This includes tightening the requirements on energy standards for new and existing buildings.

This is accompanied by a classification of buildings into efficiency classes and the issuance of energy certificates for residential buildings. In the building itself, relevant standards are established to define the respective building automation requirements. These are considered to include such aspects as the energy performance of buildings for the evaluation of efficiency of investments (EN 15232) and the requirements on air quality (Directive VDI 6022).

Also to be taken into account is an increasing number of regulations and

standards in order to lower primary energy consumption and to reduce CO₂ emissions.



CO₂-Balance – ecological aspects of building utilization

The table below shows the environmental impact of 1 kWh heating energy depending on the source of energy:

Unit	Functional Unit	Greenhouse Gas Potential
		kg CO ₂ equivalent / kWh
Oil	kWh	0,313
Natural Gases	kWh	0,263
Electricity	kWh	0,576
Wood	kWh	0,014

Source: Green Building Challenge Manual (GBC, International Network for Building Rating Systems)

The use of present data in conjunction with any data on heating energy consumption allows easy calculation of the CO₂ performance of a building over a period of one year. If, for example, the energy consumption is 50 kWh/m² and per year, the house has a surface of 150 m² and is equipped with gas heating, this corresponds to a CO₂ emission (greenhouse gas potential) of 0.263 x 50 x 150 = 1,972.5 kg CO₂.

Practical examples:

Solution approaches to air quality improvements and reduction of CO₂ emissions

Today, speed controlled fans are one of the trend setting solutions to energy optimization and energy saving in ventilation systems and to air quality improvement:

The assessment of air quality is nowadays carried out by means of CO₂ and so-called VOC mixed gas sensors (VOC: volatile organic compounds).

VOC sensors do not assess the concentration of a single gas but evaluate the mixed gas as air quality (0 – 100 %). Detectable gases, for example, include mixed gases, alkanol vapors, cigarette smoke, breathing air, etc.

In the example below, the air quality between 0 – 50 % for the air conditioning of a production hall was rated as „good“ and the

setpoint was set to 50 %. If the value rises above 50 %, the control signal for the fan speed is increased accordingly. The temperature control also impacts on the fan speed. A maximum selection causes the largest signals of the two control circuits to switch to the frequency inverter.

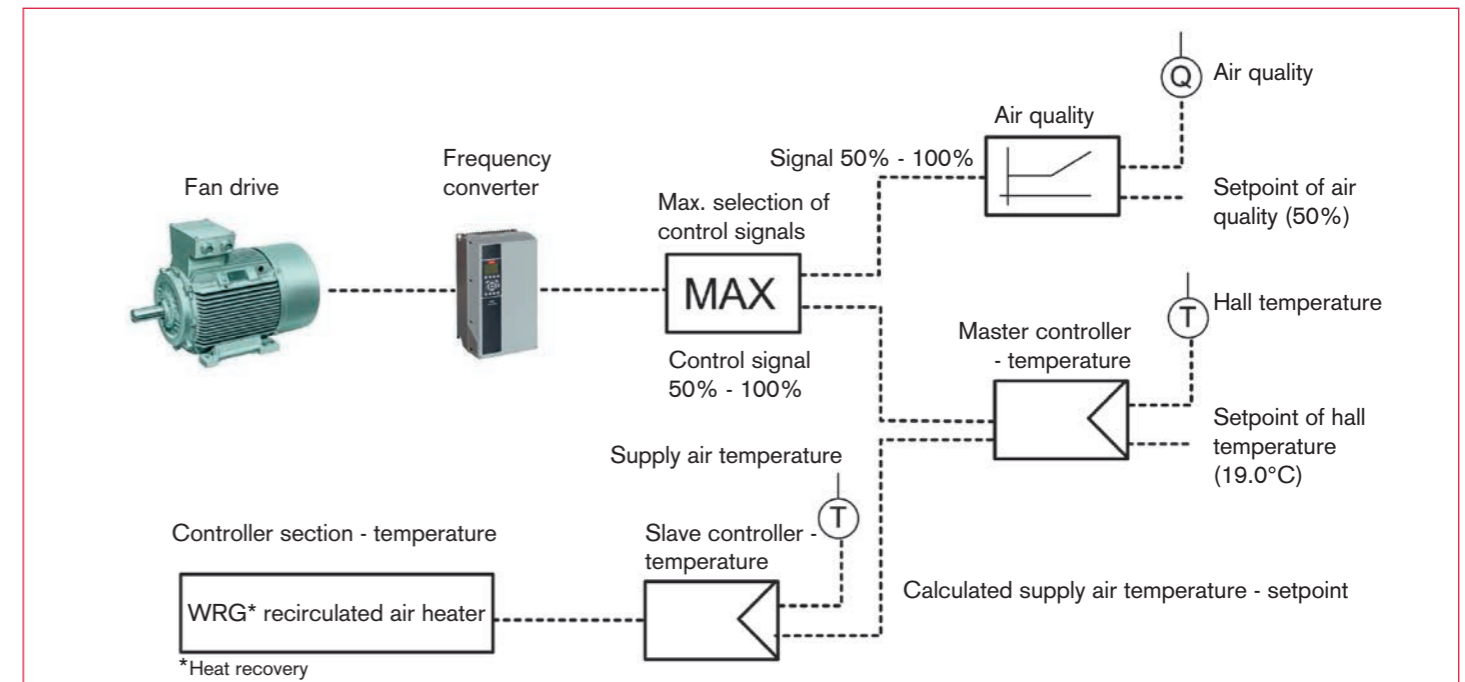

Air quality control

On the basis of the responsible plant engineers own calculation, it was possible to reduce the energy consumption of this production facility by 50 % by means of an actually realized 20 % speed reduction of the fans.

Example:

Supply air fan 15 kW, exhaust air fan 15 kW

Total	30 kW
Running time per week (2 shifts)	80 h
Weeks per year	48
Total running time	3.840 h
Energy consumption	115.200 kWh
Reduction to 50 %	57.600 kWh
CO ₂ emission steam coal heating plant	700 g per kWh

Reduction CO₂ emission

40.320 kg



Price per kWh	0,01 €
Price per year	1.152,00 €
Reduction to 50 %	576,00 €

Air quality control
Sample calculation reduction CO₂

Source: **Online**
Industrielektronik und Anlagentechnik GmbH

Use controlled ventilation systems

Modern fans are currently equipped with calibrated piezometer rings allowing the effective pressure to be assigned to the volume flow of the ventilation fan. This differential pressure method enables the static pressure before the inlet nozzle to be compared with the static pressure inside the inlet nozzle at the place of its strongest constriction.

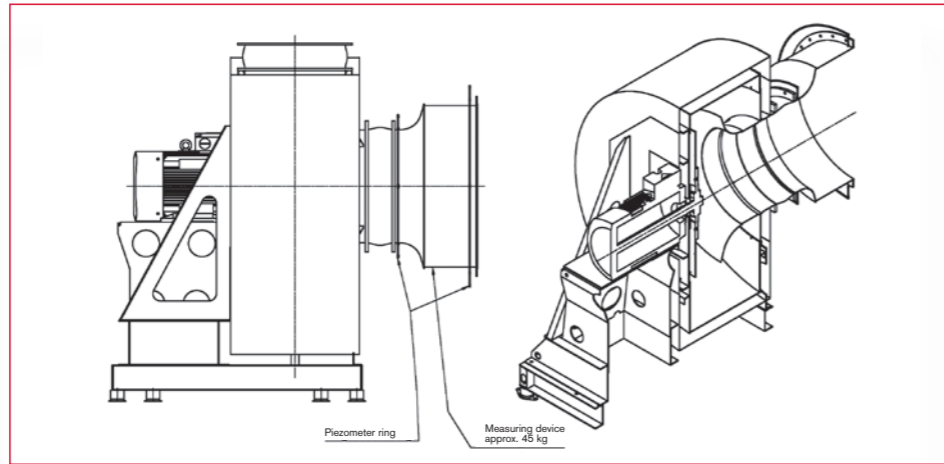

Ring nozzle radial ventilator volume flow measuring device

Based on the conservation of energy principle the effective pressure p_w' (differential pressure of the static pressures) can be allocated to the volume flow q_v as follows:

$$q_v = k \times \sqrt{\Delta p_w}$$

with k taking into account the specific nozzle properties. As a rule, the k value serves to select the specific fan size. The relevant characteristic curves are individually documented for the various fan series by the respective manufacturer.

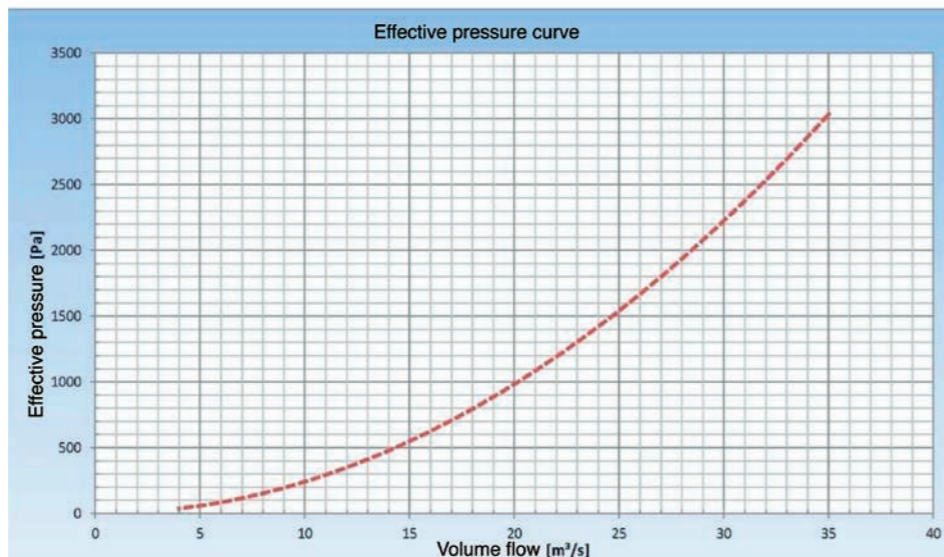

Example of a characteristic curve of a traditional ventilating fan

On the basis of the recorded characteristic curves (pressure-volume flow diagram) the differential pressure transmitter, in conjunction with other sensors and the control unit, which serves to control the frequency converter, is able to create a closed control chain.

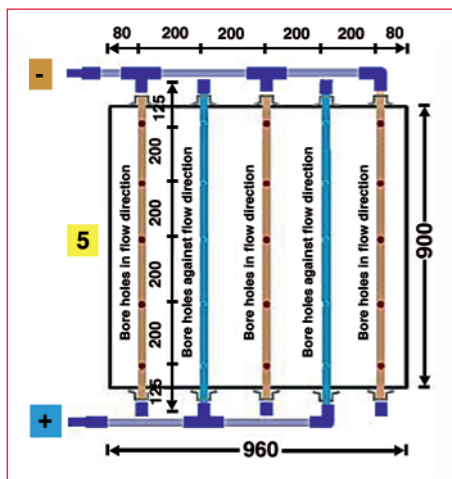

Measuring grid

In the absence of any calibrated nozzles, existing installations in particular, too, can be refitted by means of so-called measuring crosses. These components are positioned in series in the ventilation channels while the differential pressure is picked up by measuring the flow direction facing toward and facing away from the volume flow. The usual distance dimensions are, for instance, around 200 mm for the staggered arrangement of the pipes.

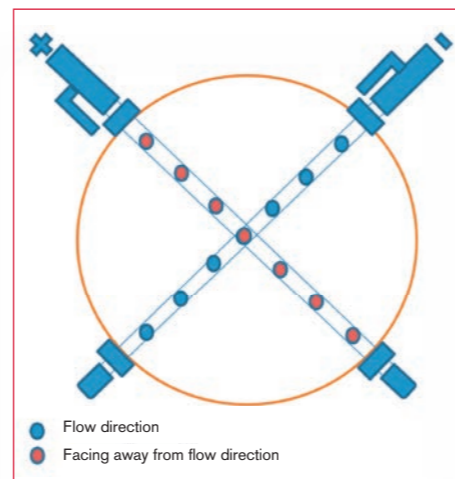

Measuring cross for pipes or chimney

The described measuring principle is ideally suited for new buildings or the refurbishment of existing buildings by way of radial fans.

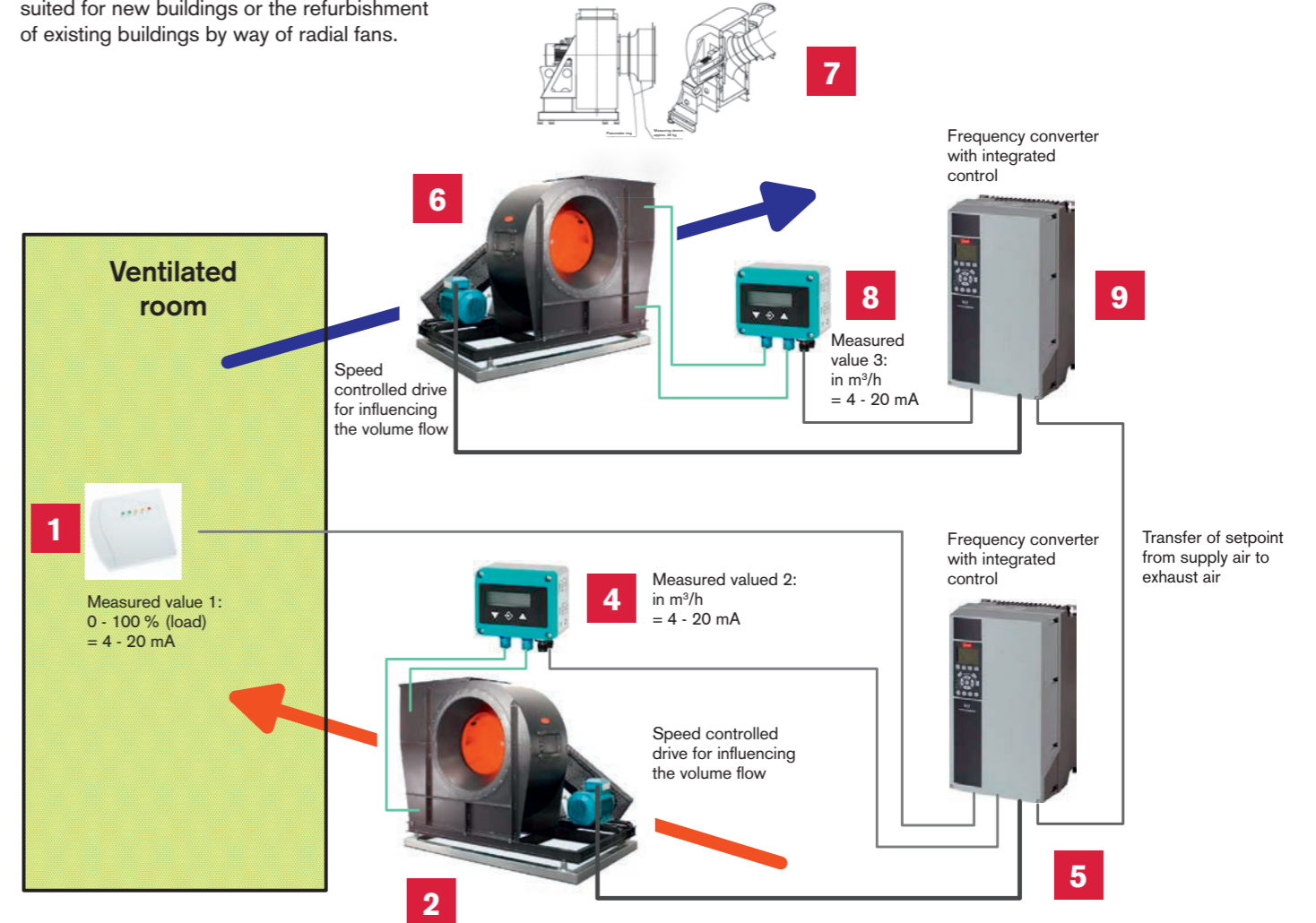

Source: **Online**
Industrielektronik und Anlagentechnik GmbH

- | | | |
|---|--|--|
| 1 Air quality measurement | 4 Volume flow measurement FISCHER Mess- und Regeltechnik DE45 | 7 Device (piezometer ring) for volume flow measurement |
| 2 Radial fan supply air | 5 Frequency converter | 8 Volume flow measurement FISCHER Mess- und Regeltechnik DE45 |
| 3 Device (piezometer ring) for volume flow measurement | 6 Radial fan exhaust air | 9 Frequency converter |

The answer for ventilation optimization – Industrial measuring technology for heating, ventilation and air conditioning (HVAC)

FISCHER Mess- und Regeltechnik GmbH is in a position to offer various differential pressure measuring instruments with basic and extension possibilities. As far as instruments with extended table functions are concerned, the characteristic curves for pressure and volume flow of the corresponding fans can be recorded in so-called value pairs. It is possible to represent up to 30 value pairs in order to guarantee a precise definition of the characteristic curve. Typically a few value pairs are sufficient. The values can be recorded independently in the unit and do therefore neither influence the storage capacity nor the computing speed of the superordinate control technology. With regard to idealized curves the square root characteristics can also be used. It is important that only the volume flow necessary for the pressure increase is applied so as to avoid unnecessary pressure increases.

The installation can accordingly be optimally designed and used in a resource saving manner. Speed controlled systems also offer the advantage that optimally controlled fans allow for noise reduction when operated below maximum performance level.

INDUSTRIAL STANDARD:

The units are mainly characterized by their sensors with finely balanced basic measuring areas enabling high accuracy and reproducibility of the measured results. Important aspects are acid proof and highly flame resistant housings. As a standard, the operating range of the units is between -20 °C and 70 °C.

In addition to traditional hose connections, the described units can also be supplied with pneumatic or cutting ring couplings as an option to provide more safety in connection technology.

- typical are its digital output signals via the RS 485 interface with Modbus RTU protocol
- the cross linking of a large number of measuring points is therefore possible by means of a line network structure with accordingly reduced installation work. The bus address as well as the communication parameters of the Modbus interface can be set from outside the unit by use of a coding switch
- the unit comes with up to 4 potential free contact inputs, for example for the initiators or binary signals of actuators. In addition to the reduced installation work the unit is also interesting for link-up to monitoring.



2 channel transmitter type DE44

- with two differential pressure measuring cells for volume flow control and filter monitoring
- V-belt monitoring also possible due to integrated switch contacts
- unit can be used for redundant tasks thanks to the two transmitters and galvanically separated switch contacts
- reduced installation work due to multifunctional features in one unit
- 6 digit LC colour change display; adjustable limit values (red, yellow, green)
- documentation and parameterization by means of laptop and according to software.
- alternatively, settings can be carried out directly on the unit with locking function by way of password protection
- ex-zone 2 version as an option (neutral gases and aerosols) or for ex-zone 22 (dusty media).



1 channel transmitter type DE45

- with differential pressure measuring cell for either volume flow control or filter monitoring
- all other options as described above.



1 channel transmitter DE 49 for explosion hazardous areas

Differential pressure transmitter DE49 is available for use in ex-zones of class 1 (II 1 / 2 G Ex in IIC T4 and II 2D Ex in D 21 T 80 °C).

Zero maintenance as a special feature

With view to heating, ventilation and air conditioning (HVAC) systems in healthcare rooms and buildings, DIN 1946-4:2008-12 stipulates, inter alia, with regard to monitoring systems that „differential pressure gauges with local display be used without sealing liquid and pressure sensor“. The use of Inclined tube manometers or capsule pressure gauges is therefore not admissible. This applies to „filters of the 1st and 2nd filter level“.

To this purpose, the FISCHER Mess- und Regeltechnik GmbH offers compact and intelligent measuring instruments which fulfill the general standard requirements. For example: „entering room class I for cleaning and maintenance“ is not necessary. Furthermore, owing to the design of the unit, „inadmissible contamination of the supply air due to inorganic or organic substances is definitely avoided ...“. In view of the present framework conditions the units are generally considered suited for use in heating, ventilation and air conditioning (HVAC) systems.



Separate collection and display of measured values

For larger distances from the measuring point to the display unit or as a parallel display special displaying and switching units of the EA14 series are available without sensor for analog input signals. The output of these remote displays is equipped with corresponding analog signals and switch contacts. The image above shows an example of the combination with two pressure transmitters type ME12.

FISCHER Mess- und Regeltechnik GmbH – A comprehensive range of products for your specific applications

FISCHER Mess- und Regeltechnik is in a position to offer a line of versatile units for a variety of requirements. In addition to the described differential pressure gauges for volume flow control, a number of measuring instruments for recording and monitoring of temperatures and pressures is also available.

DE44 with colour change (2 channel transmitter)



- Measuring range > 4 mbar
- 0 - 20 mA
- 4 - 20 mA 3-conductor
- 0 - 10 V
- Square rooting: display / output
- LCD measured value display
- U_B 24 V DC/AC
- Operation: membrane keyboard
- PC adapter EU 03
- PC software
- Screw connection for hoses
- Relay / Semi conductor contact
- Panel mounting, as an option
- Clean room application flush mounted

DE45 with colour change (1 channel transmitter)



- ATEX II3G - LCD version
- ATEX II3D - LCD version

DE46 with colour change (1 channel low pressure transmitter)



- Measuring range > 25 Pa
- 0 - 20 mA
- 4 - 20 mA 3-conductor
- 0 - 10 V
- Square rooting: display / output
- LCD measured value display
- U_B 24 V DC/AC
- Operation: membrane keyboard
- PC adapter EU 03
- PC software
- Screw connection for hoses
- Relay / Semi conductor contact
- Panel mounting, as an option
- Clean room application flush mounted
- ATEX II3G - LCD version
- ATEX II3D - LCD version

EA14D with colour change



- ΔP measurement by means of a difference between two external pressure sensors
- Measuring ranges: 2,5 - 100 bar
- 0 - 20 mA
- 4 - 20 mA 3-conductor
- 0 - 10 V
- LCD measured value display
- U_B 24 V DC/AC
- Operation: membrane keyboard
- PC adapter EU 03
- PC software
- Relay / Semi conductor contact
- Panel mounting, as an option

EA14M with colour change



- Pressure / level measurement by means of evaluation of an external sensor
- Possible input signals of external sensor:
- 0 - 20 mA
- 4 - 20 mA 3-conductor
- 0 - 10 V
- Electr. output signals:
- 0 - 20 mA
- 4 - 20 mA 3 conductor
- 0 - 10 V
- LCD measured value display
- U_B 24 V DC/AC
- Operation: membrane keyboard
- PC adapter EU 03
- PC software
- Relay / Semi conductor contact
- Panel mounting, as an option

DE49_0



- Measuring range > 4 mbar
- 4 - 20 mA 2-conductor
- Square rooting: display / output
- LCD measured value display
- U_B 24 V DC
- Operation: membrane keyboard
- Screw connection for hoses
- Explosion protection:
- II 1/2 G Ex ia IIC T4
- II 2 D Ex ia D 21 T80 °C
- 10...60 °C
- 0...4 mbar, p max. 50 mbar to
- 0...100 mbar, p max. 500 mbar

FISCHER Mess- und Regeltechnik GmbH supplies an optimally customised model series for these applications.

The measuring instruments are distinguished by:

- ▲ Families of measuring instruments for various measuring tasks
- ▲ Comfortable user prompt
- ▲ Tables for asymmetric tank containers or flow measurements may be saved
- ▲ Some instruments with extended proofs (EAC, SIL, GL, KTA, structural testing, etc.)
- ▲ Industry-compliant equipment for housings and process connections
- ▲ Special instruments with colour-change displays for visualisation of operating conditions (e.g. warnings, alarms)
- ▲ Extended range with touch-sensitive user interface
- ▲ Customer-specific system solutions

Numerous references from the areas of system planning, system engineering and construction and from operators prove the quality of our products.

FISCHER Mess- und Regeltechnik GmbH offers individual concept solutions for your application.

We are an owner-operated family business with efficient decision-making processes.

We offer our customers tailored systems and product solutions, as well as OEM products.

Our devices and solutions are optimally suited for a variety of applications, such as:

- ▲ Pressure measurement (under- and over-pressure)
- ▲ Differential pressure measurement
- ▲ Flow measurement
- ▲ Temperature measurement
- ▲ Level measurement
- ▲ Humidity measurement
- ▲ Control systems

Our sales engineers are available for a detailed consultation regarding our products and solutions. Contact details can be found on our website:

www.fischermesstechnik.de

FISCHER Mess- und Regeltechnik GmbH

Bielefelder Straße 37a · 32107 Bad Salzufen · GERMANY · Phone +49 5222 974-270 · Fax +49 5222 7170
Email: info@fischermesstechnik.de · Web: www.fischermesstechnik.de