



Manual

RT

Clean room panel

For clean rooms and safety laboratories
in compliance with DIN EN ISO 14644-1 and GMP

09005692 HB_EN_RT ST4-C 10/17

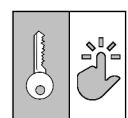
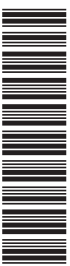

Masthead

Manufacturer:**FISCHER Mess- und Regeltechnik GmbH**

Bielefelderstr. 37a
32107 Bad Salzuflen

Telephone: +49 5222 974 0
Telefax: +49 5222 7170

eMail: info@fischermesstechnik.de
web: www.fischermesstechnik.de

Sales department

Telephone: +49 5222 974 270
Telefax: +49 5222 7170

Technical editorial team:

Documentation representative: S. Richter
Technical editor: R.Kleemann

All rights, also those to the translation, reserved. No part of these instructions may be reproduced or processed, duplicated or distributed using electronic systems or any other form (print, photocopy, microfilm or another process) without the written consent of the company FISCHER Mess- und Regeltechnik GmbH, Bad Salzuflen.

Reproduction for internal use is expressly allowed.

Brand names and procedures are used for information purposes only and do not take the respective patent situation into account. Great care was taken when compiling the texts and illustrations; nevertheless, errors cannot be ruled out. The company FISCHER Mess- und Regeltechnik GmbH will not accept any legal responsibility or liability for this.

Subject to technical amendments.



© FISCHER Mess- und Regeltechnik GmbH 2015

Version history

Rev. ST4-A 01/15	Version 1 (first edition)
Rev. ST4-B 08/15	Version 2 (Correction Assesories)
Rev. ST4-C 10/17	Version 3 (Correction Long Term Drift FT61)

Table of contents

1 Safety notes	5
1.1 General.....	5
1.2 Personnel Qualification	5
1.3 Risks due to Non-Observance of Safety Instructions.....	5
1.4 Safety Instructions for the Operating Company and the Operator	5
1.5 Unauthorised Modification	5
1.6 Inadmissible Modes of Operation	5
1.7 Safe working practices for maintenance and installation work.....	6
1.8 Pictogram explanation.....	6
2 Product and functional description	7
2.1 Delivery scope	7
2.2 Use as intended	7
2.3 Product overview	7
2.4 Design and mode of operation	8
3 DE24 Room pressure transmitter/indicator	9
3.1 Use as intended	9
3.2 Design and mode of operation	9
3.3 User guide	10
3.4 Technical data	21
4 FT61 Humidity and temperature measuring device	24
4.1 Use as intended	24
4.2 Design and mode of operation	24
4.3 User guide	24
4.4 Technical data	36
5 EA14 Universal display	38
5.1 Use as intended	38
5.2 Design and mode of operation	38
5.3 User guide	39
5.4 Technical data	51
6 TW68 Resistance thermometer	52
6.1 Use as intended	52
6.2 Design and mode of operation	52
6.3 Technical data	52
7 Display and control elements	54
7.1 Command and alarm devices.....	54
7.2 Calibration pipes.....	57
7.3 Calibration valve.....	57
7.4 Room pressure filter element	57
7.5 Reference pressure connection	58
8 Assembly and commissioning	59
9 Maintenance, servicing and disposal	60
9.1 Maintenance.....	60
9.2 Transport	60
9.3 Service	60
9.4 Disposal.....	60

10 Technical information	61
10.1 General.....	61
10.2 Application conditions.....	61
10.3 Auxiliary energy	61
10.4 Construction design.....	61
11 Order Codes	62
12 Accessories	66
12.1 Reference pressurized container	66
12.2 Reference pressure distributor	67
12.3 Separation element	67

1 Safety notes

1.1 General

WARNING

This operating manual contains instructions fundamental to the installation, operation and maintenance of the device that must be observed unconditionally. It must be read by the assembler, operator and the specialized personnel in charge of the instrument before it is installed and put into operation.

This operating manual is an integral part of the product and therefore needs to be kept close to the instrument in a place that is accessible at all times to the responsible personnel.

The following sections, in particular instructions about the assembly, commissioning and maintenance, contain important information, non-observance of which could pose a threat to humans, animals, the environment and property.

The instrument described in these operating instructions is designed and manufactured in line with the state of the art and good engineering practice.

1.2 Personnel Qualification

The instrument may only be installed and commissioned by specialized personnel familiar with the installation, commissioning and operation of this product.

Specialized personnel are persons who can assess the work they have been assigned and recognize potential dangers by virtue of their specialized training, their skills and experience and their knowledge of the pertinent standards.

1.3 Risks due to Non-Observance of Safety Instructions

Non-observance of these safety instructions, the intended use of the device or the limit values given in the technical specifications can be hazardous or cause harm to persons, the environment or the plant itself.

The supplier of the equipment will not be liable for damage claims if this should happen.

1.4 Safety Instructions for the Operating Company and the Operator

The safety instructions governing correct operation of the instrument must be observed. The operating company must make them available to the installation, maintenance, inspection and operating personnel.

Dangers arising from electrical components, energy discharged by the medium, escaping medium and incorrect installation of the device must be eliminated. See the information in the applicable national and international regulations.

Please observe the information about certification and approvals in the Technical Data section.

1.5 Unauthorised Modification

Modifications of or other technical alterations to the instrument by the customer are not permitted. This also applies to replacement parts. Only the manufacturer is authorised to make any modifications or changes.

1.6 Inadmissible Modes of Operation

The operational safety of this instrument can only be guaranteed if it is used as intended. The instrument model must be suitable for the medium used in the system. The limit values given in the technical data may not be exceeded.

The manufacturer is not liable for damage resulting from improper or incorrect use.

1.7 Safe working practices for maintenance and installation work

The safety instructions given in this operating manual, any nationally applicable regulations on accident prevention and any of the operating company's internal work, operating and safety guidelines must be observed.

The operating company is responsible for ensuring that all required maintenance, inspection and installation work is carried out by qualified specialized personnel.

1.8 Pictogram explanation

DANGER

Type and source of danger

This indicates a **direct** dangerous situation that could lead to death or **serious injury** (highest danger level).

a) Avoid danger by observing the valid safety regulations.

WARNING

Type and source of danger

This indicates a **potentially** dangerous situation that could lead to death or **serious injury** (medium danger level).

a) Avoid danger by observing the valid safety regulations.

CAUTION

Type and source of danger

This indicates a **potentially** dangerous situation that could lead to slight or serious injury, damage or **environmental pollution** (low danger level).

a) Avoid danger by observing the valid safety regulations.

NOTICE

Note / advice

This indicates useful information of advice for efficient and smooth operation.

2 Product and functional description

2.1 Delivery scope

- Clean room panel according to specification
- Manual
- Electro-technology documents

2.2 Use as intended

The clean room panel is suitable for monitoring room parameters in clean rooms and safety laboratories in compliance with DIN EN ISO 14644-1 Class 1-9 and according to GMP Class A-D.

Depending on the version, the following parameters can be monitored:

- Room pressure
- Room temperature
- Room humidity
- Particle
- Current

The measuring devices, sensors, control elements etc. used in the clean room panel can be configured as required.

2.3 Product overview

Because the clean room panels are customised, the various components are described based on a randomly selected example.

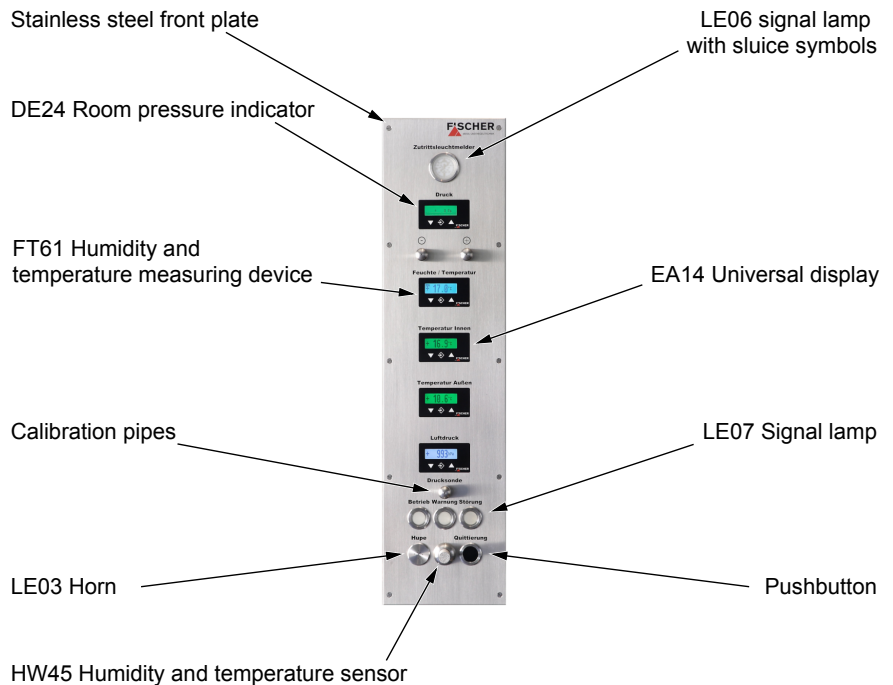

Illustration 1: Components

2.4 Design and mode of operation

The design and function are stated in the wiring diagram in the electro-technology documents included in every delivery. For explanations about operation, please see the respective section of the installed components in this manual.

The following measuring components can be installed in a clean room panel:

- DE24 Room pressure transmitter/indicator [▶ 9]
- FT61 Humidity and temperature measuring device [▶ 24]
- EA14 Universal display [▶ 38]
- TW68 Resistance thermometer [▶ 52]

3 DE24 Room pressure transmitter/indicator

3.1 Use as intended

This device is suitable for use as a display and switch device for measuring and monitoring the room pressure in clean rooms and safety laboratories.

3.2 Design and mode of operation

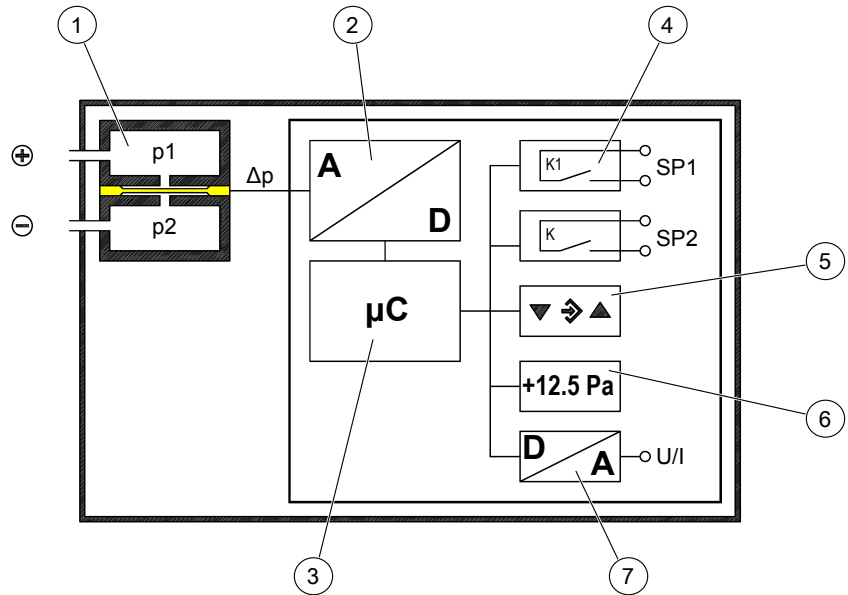

Illustration 2: Function diagram

1	Measuring cell	2	Signal conversion
3	Microcontroller	4	Switch output
5	Keyboard	6	Display
7	Analogue output		

The DE24 is based on a capacitive sensor element that is suitable for measuring overpressure, underpressure and differential pressure.

The measured pressure acts on the sensor element with a micro-mechanically produced differential condenser in silicon-glass technology.

Changes in pressure generate changes in capacity, which is evaluated by the device's electronics and transformed into signals on the display, switch contacts and an output signal.

3.3 User guide

3.3.1 Display

(a) Standard display

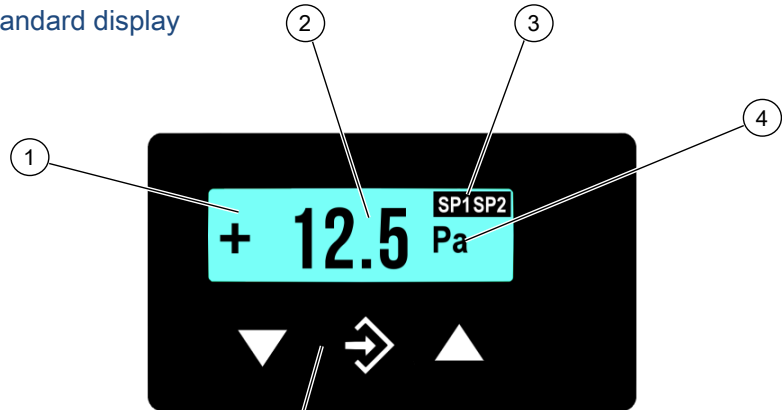

(b) Bar chart display

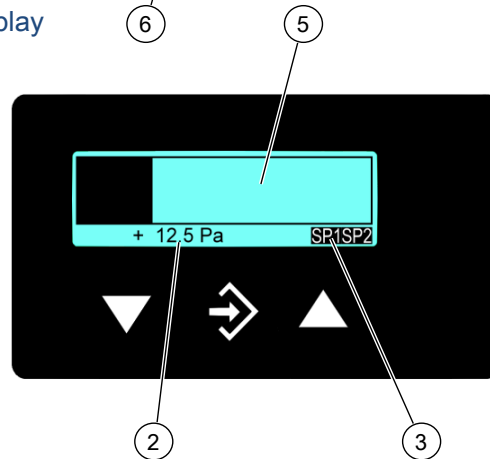

Illustration 3: Room pressure display

1	LCD with back lighting	2	Measured Value Display
3	Status display of the switch points	4	Unit
5	Bar chart display	6	Keyboard

In normal mode, the current measured value is shown on a 4-digit LC display. To show very large values, it is possible to switch to a 5 or 6-digit presentation (see Parameter **MB decimal place**).

SP1SP2

Illustration 4: LCD Switch points

The unit is shown on the right of the display. If the device is equipped with contacts, a closed contact is always symbolised by an inverted text "SP1" or "SP2".

Various colours can be selected for the back lighting. Depending on the measured value, the colour of the back lighting can be automatically changed. This can be used e.g. to depict good/poor differences. The back lighting can also be deactivated.

The measured value can also be shown in a bar chart. The measured value is also shown in smaller pictures as a number.

During the programming, the menu items and the associated parameters are shown on the display. The device continues to function whilst the parameters are being set; apart from one exception, the changes come into effect instantly. The exception here is a change of switching times - here the previously valid time must have run down.

3.3.2 Keyboard

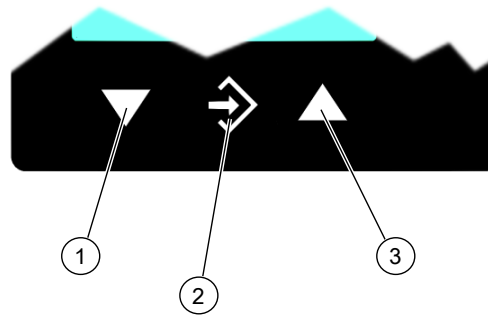

Illustration 5: Operating keys

1	Page down menu	Reduce value	
2	Call up menu	Save value	OK
3	Page up menu	Increase value	

The individual menu items and parameters can be displayed using the buttons ▲ and ▼. The respective menu item is selected or the parameters for making changes are called up via the button ⇨.

If a parameter can be changed, the display flashes. The change is made via the buttons ▲ and ▼. The value is saved with the button ⇨.

To leave a menu level or the entire menu, select the parameter "Quit" and press ⇨.

Example:

Switch-on point set switchpoint 1

In normal mode, press the button ⇨ to enter the menu. The **menu level Switch points** appears. Press the enter key ⇨ again to call up the display parameter.

The first parameter **Switch point 1 on** is displayed. To change this parameter, press the button ⇨ again.

The device jumps to the input:

- The parameter is stated in the 1st line.
- The value that is to be changed is shown in the 2nd line, the display flashes.
- The input limits are displayed in the 3rd line (if there is one).

The required value is set with the buttons ▲ and ▼ and then confirmed with ⇨.

3.3.3 Menu levels

The menu levels are structured as follows:

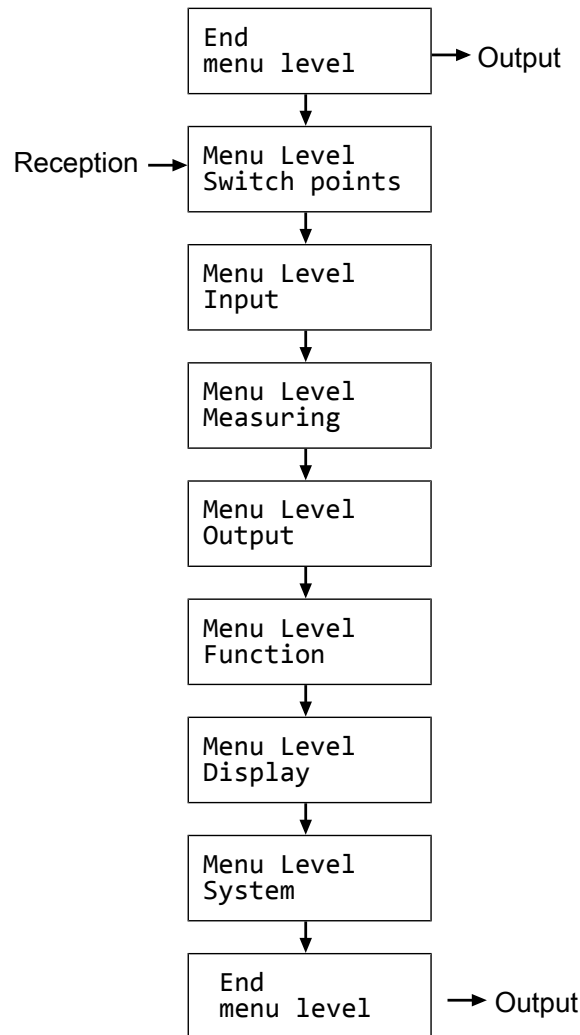

Illustration 6: Menu levels

The following tables provide an overview of the parameters of the individual menu levels. In the Menu Level System you can change to the respective national language using the language parameter. You can see which languages are supported there.

3.3.3.1 Menu Level Switch points

Parameter name	Description	Value range
SP1 On	Switch point 1 On	MRS-50% ... MRE+50%
SP1 Off	Switching point 1 off	MRS-50% ... MRE+50%
SP1 Delay	Switching point 1 delay	0...1800 s
SP1 Function	Switching point 1 function	NO, NC
SP2 On	Switch point 2 On	MRS-50% ... MRE+50%
SP2 Off	Switching point 2 off	MRS-50% ... MRE+50%
SP2 Delay	Switching point 2 delay	0...1800 s
SP2 Function	Switching point 2 function	NO, NC

The two switch outputs are configured by four parameters respectively. For the switch point 1 these are

- **SP1 On**
- **SP1 Off**
- **SP1 Delay**
- **SP1 Function**

Accordingly for switch point 2:

- **SP2 On**
- **SP2 Off**
- **SP2 Delay**
- **SP2 Function**

The function of the individual parameters is explained for both switch points using Switch point 1 as an example.

SP1 On defines the activation point, **SP1 Off** the deactivation point of switch output 1. The values are shown in the valid unit and set accordingly. The values are shown in the valid unit and set accordingly. Both parameters can be set independently over the entire value range.

The value range ranges from MRS – 50% to MRE + 50%. MRS stands for measuring range start and MRE for measuring range end.

Example:

Measurement range = 0 ... 100 Pa

The value range for this measuring range is -50 Pa ... +150 Pa.

Together, the two parameters **SP1 On** and **SP1 Off** determine the switch function of switch output 1:

- If **SP1 On** > **SP1 Off**, the output switches on, if the measured value exceeds SP1 On. It is only switched off again if the measured value SP1 Off is undercut (hysteresis function).
- If **SP1 On** = **SP1 Off**, the output switches on if the measured value exceeds SP1 On and off if the measured value undercuts the same value (SP1 Off).
- If **SP1 On** < **SP1 Off**, the output switches on, if the measured value lies within these switch points: i.e:
SP1 On < Measured value < **SP1 Off** (window function).

SP1 Delay allows the reaction of the switch output to be delayed by between 0 and 1800 s. This parameter applies equally for switching on and off.

SP1 Function changes the function of the switch output 1. It is possible here to define whether the contact should work as a open contact (NO) or a break contact (NC).

3.3.3.2 Menu Level Input

Parameter name	Description	Value range
Absorption	Attenuation, damping	0...100 s
Offset corr.	Offset correction	1/3 basic measuring range
Zero-pt. wind.	Zero-point window	1/3 basic measuring range

If there are unsteady pressure readings during operation, you can use the parameters **Absorption** and **Zero-pt. wind.** to stabilise the reading and the output signal.

The parameter **Absorption** functions like a capillary throttle. However, it only acts on the display, output signal and switch points (if these exist) but not on the measuring cell itself.

You can set the response time to pressure jumps in the range 0.0 to 100 s.

NOTICE

Response time

At maximum damping it can take over 2 minutes until the pressure jump from the nominal pressure 100% to 0% is also shown as zero in the display.

In many cases, unsteady readings are not a problem during normal operating mode, but this is not true for the idle state, i.e. if a measured value of zero is expected. The parameter **Zero-pt. wind.** is designed to solve this. Its value defines a range around zero at which the measured value is set to zero (see fig.).

The display only stops showing zero when the pressure leaves the set window. When twice the window value is reached, the measuring pressure and the display correspond again. This avoids jumps in the display.

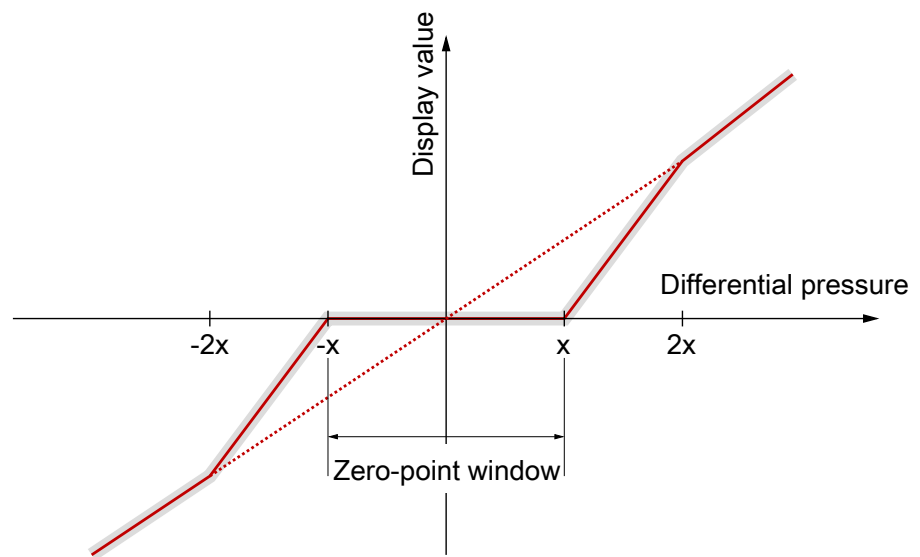

Illustration 7: Zero-point window

It makes sense to set the Offset (zero-point displacement) if, without differential pressure (remove measuring line), the display shows a value that is not zero. Before the offset correction, the zero-point window must be set to zero.

Select the **Offset corr.** parameter and correct the reading using the buttons ▲ or ▼ until zero is shown in the display.

When setting the offset, the current measured value is displayed. The zero-point window is not active during the offset setting.

3.3.3.3 Menu Level Measuring

Parameter name	Description	Value range
MB start	Measuring range start	Basic measuring range
MB end	Measuring range end	Basic measuring range
Unit	Measuring range unit	bar, mbar, Pa, kPa, MPa, psi, InWc, mmWs, mmHg
Limit	Measuring range limit	yes, no

The transmitter output signal primarily depends on the sensed pressure. However, you have the option of adjusting the output signal to a large extent to suit your requirements.

NOTICE

Adjustment of the output signal

The basic measuring range (indicated on the type label) and the type of output signal (voltage / current) are not variable.

The parameters **MB start** and **MB end** initially define the two pressures between which the output signal will change at all. Both values are adjustable across the entire basic measuring range. The set values also refer to the pressure in the respective unit. However, the signal values (current / voltage) for 'Start of measuring range' and 'End of measuring range' are fixed.

If **MB start** is smaller than **MB end**, this is called an increasing characteristic curve; the output signal increases as the pressure increases.

If **MB end** is smaller than **MB start**, this is a decreasing characteristic curve and the output signal decreases as the pressure increases.

The difference between the values **MB start** and **MB end** must be at least 25 % of the basic measuring range.

You can select a unit other than the unit of the basic measuring range with the parameter **Unit**. The user should remember however that not every unit is suitable. The conversion is automatic.

The parameter **Limit** allows the display, output and switching points to be limited to the range between Start of measuring range and End of measuring range. This makes sense when content is measured to avoid "negative contents". If Limit is set to "no", those measured values that are greater or smaller than the end values are shown.

3.3.3.4 Menu Level Output

Parameter name	Description	Value range
min. output	min. output	
max. output	max. output	0.0 ... 21.0 mA or 0.0 ... 11.0 V
Error signal	Measuring range unit	

The parameters **min. output**, **max. output** and **error signal** define the limits of the output signal that may not be undercut or exceeded regardless of the pressure. The limit values take priority over the range defined by the **MB start** and **MB end** parameters! These parameters primarily serve to prevent error messages in downstream systems caused by brief overstepping of measuring ranges.

The parameter **min. output** is usually only used for devices with an output signal 4...20 mA because frequently values of below 3.8 mA are evaluated as error signals.

The **max. output** value can be used for the voltage and current to limit the maximum value.

The value defined via the parameter **Error signal** is issued if the device detects an internal error and can no longer work correctly. It should be noted here that not all potential errors and faults can be detected by the device itself.

3.3.3.5 Menu Level Function

The Function menu level is a variable menu whose appearance depends on the value of the Function parameter. There are linear, square rooted and table functions

Linear function

The input signal is linear before being sent to the display and the output. The range defined in the menu "Measuring" serves as the measuring range. If the function LINEAR is active, the other menu items are cancelled.

Parameter name	Description	Value range
Function	Function	Value = linear

Square rooted function

Here, the input signal is square rooted before being sent to the display and the output. This is necessary e.g. for flow measurements with differential pressure. A free unit can be defined for the display. To do this, the start and end of the display range and the number of decimal points are defined. It is also possible to define the unit with 4 characters.

Parameter name	Description	Value range
Function	Function	Value = square rooted
MB decimal pl.	Measuring range decimal places	1234, 123.4, 12.34, 1,234, 12345, 123456
MB start	Measuring range start	-9999 ... +9999
MB end	Measuring range end	-9999 ... +9999
MB unit	Measuring range unit	4 characters

The following section contains descriptions of the parameters **MB decimal pl.**, **MB start**, **MB end** and **MB unit** to describe the table function.

Tables function

This function allows free adjustment of the input variable to the display and output via a table with up to 30 support points. A value pair comprising a measured value and display value is issued for every support point.

NOTICE

Change of parameter

When switching from TABLE to another function, the table is initialised again and the existing values are lost.

Parameter name	Description	Value range
Function	Function	Value = Table
MB decimal pl.	Measuring range decimal places	1234, 123.4, 12.34, 1,234, 12345, 123456
MB start	Measuring range start	-9999 ... +9999
MB end	Measuring range end	-9999 ... +9999
MB unit	Measuring range unit	4 characters
No. of pairs	Number of pairs	n = 3...30
Value pair1	Value pair 1	MB-start ... MB-end
Value pair2	Value pair 2	
Value pair3	Value pair 3	
	...	
Value pair30	Value pair 30	

The display range is defined with the parameters **MB decimal pl.**, **MB start** and **MB end**. The user can select the configuration freely.

Using the parameter **MB decimal pl.**, it is possible to select between a 5 or 6-digit presentation. The resolution is not increased. Only an extra zero or two zeros are added. This serves the correct display of larger values. The measuring range must be positive for the 6 digit presentation.

The **MB unit** gives the user the option of defining a completely independent unit. Letters, numbers or special characters can be used. The unit can be max. 4 characters long.

If the function TABLE is selected, then it is also necessary to state the **No. of pairs**. It is defined here how many pairs of values (support points) are used in the table. A table is made up of at least 3, max. 30 support points.

NOTICE

Number of value pairs

If the number of value pairs is changed, the table is initialised again and the existing values are deleted.

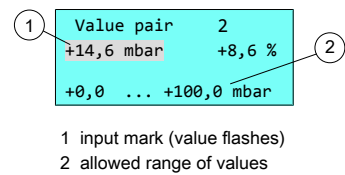

Illustration 8: Value pair

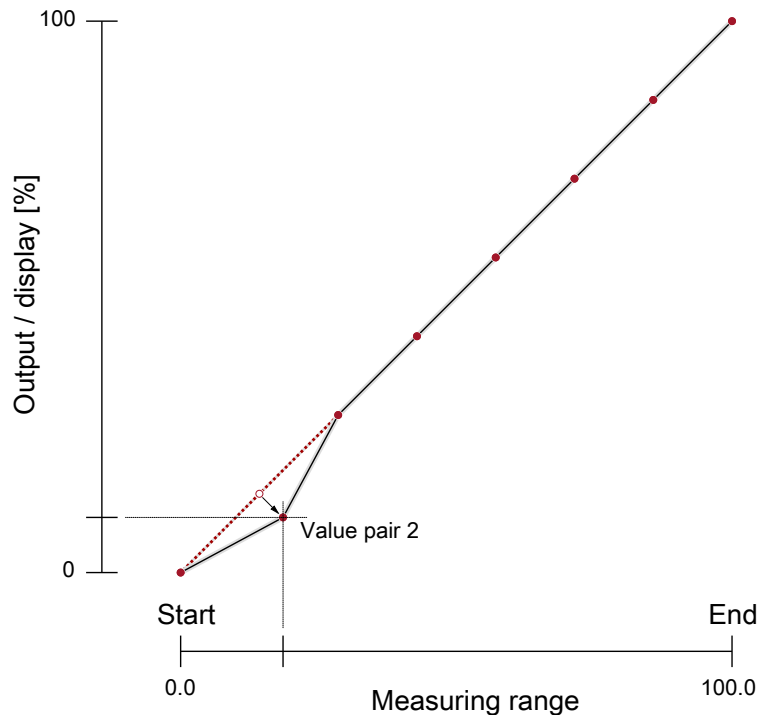

Illustration 9: Table function (example)

The individual value pairs can be seen and changed with the **Value pair1** to **Value pair30** parameters. A value pair comprises a measured value (left side) and a display value (right side). The measured value must lie within the measuring range and the display value must lie within the defined "free unit". The respective limits are shown during input. The table must contain either increasing or decreasing values. the table must contain either continuously increasing or continuously failing values. A change from an increasing to a decreasing characteristic curve within a support point table is not allowed.

3.3.3.6 Menu Level Display

The Display menu level is a variable menu whose appearance depends on the value of the colour parameter. In addition to the various colours for the background lighting, there are also two auto-functions with colour switching available.

Parameter name	Description	Value range
Colour	Colour	Off, red, green, yellow, blue, pink, turquoise, white, Auto1: Red-green Auto2: Red-yellow-green
Lighting	Lighting time	0 s, 10 ... 600 s
Contrast	Contrast	15 ... 45
Bar chart	Barchart display	yes, no

The most important parameter is **Colour**. A fixed colour can be defined for the background colour here. There are also two auto-functions with colour switching available. Alternatively, the background illumination can be permanently deactivated.

If permanent lighting is not required, the parameter **Lighting time** can be used to define when the lighting should be switched off after the last time a button is pressed. In addition to permanent lighting (0 s), automatic shut-down after 10... 600 s is also possible. The set time is only valid if the parameter **Colour** is not set to "off".

Amongst other things, the legibility of the display depends on the temperature and the reading angle. To ensure optimised legibility, the display can be adjusted using the parameter **Contrast**. When the contrast is changed, it is possible that the display appears empty or almost completely black. In this case, the contrast must be turned up or down.

Via the parameter **Bar chart**, the display can be switched between a display where the measured value is either shown in large digits or the display shows small digits and an additional barchart.

Auto1: Colour-change red to green

In the mode with the automatic colour switchover, it is possible to enter the required switch thresholds "red-green switchover", "green-red switchover".

The switching thresholds can be moved within the measuring range. The series of switch points cannot be altered.

Parameter name	Description	Value range
Red-Gr. switch.	Red-green switching	MRS - 50% ...
Gr-Red switch.	Green-red switching	MRE + 50%
Hysteresis	Hysteresis	0.1 ... 10.0 %
Delay	Delay	0 ... 1800 s
Colour	Colour	Off, red, green, yellow, blue, pink, turquoise, white, Auto1: Red-green Auto2: Red-yellow-green
Lighting	Lighting time	0 s, 10 ... 600 s
Contrast	Contrast	15 ... 45
Bar chart	Barchart display	yes, no

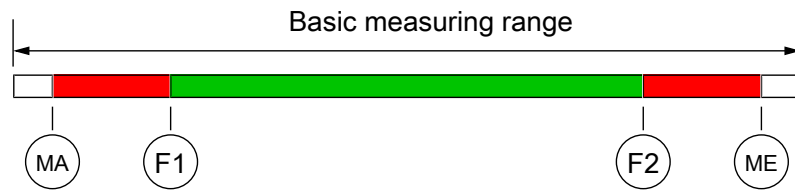

Illustration 10: Function Auto1

MA	MB-start	Measuring range start
F1	Red-Gr. switch.	Red-green switching
F2	Gr-Red switch.	Green-red switching
ME	MB-end	Measuring range end

The parameter **Hysteresis** can be used to prevent fast and unwanted colour changes. The hysteresis is set in the range 0.1... 10%.

NOTICE

Overlapping colour areas

Note: In the case of large hysteresis values, steps must be taken to ensure that the ranges of the individual colours do not overlap. Otherwise it is possible that the colour change may not function in the desired way.

The parameter **Delay** offers a further option to prevent unwanted colour changes. The colour change here can be delayed between 0...1800 s.

The parameter **Lighting** can be used to define when the lighting should be switched off after the last time a button is pressed. In addition to permanent lighting, automatic shut-down after 10...600 s is also possible. The set time is only valid if the parameter **Colour** is not set to "off". The lighting can be switched on permanently with the value 0s.

The legibility of the display can be adjusted using the parameter **Contrast**. When the contrast is changed, it is possible that the display appears empty or almost completely black. In this case, the contrast must be turned up or down again.

Via the parameter **Bar chart**, the display can be switched between a display where the measured value is either shown in large digits or the display shows small digits and an additional barchart.

Auto2: Colour-change red-yellow-green

In the Auto 2 mode with the automatic colour switchover, it is possible to enter the required switch thresholds "red-yellow switchover", "yellow-green switchover", green-yellow switchover, "yellow-red switchover".

The switching thresholds can be moved within the measuring range. The series of switch points cannot be altered.

Parameter name	Description	Value range
Red-Yell.switch.	Red-yellow switchover	MRS - 50% ... MRE + 50%
Yell.-Gr.switch.	Yellow-green switchover	
Gr.-Yell. switch	Green-yellow switchover	
Yell.-Red switch	Yellow-red switchover	
Hysteresis	Hysteresis	0.1 ... 10.0 %
Delay	Delay	0 ... 1800 s

Parameter name	Description	Value range
Colour	Colour	Off, red, green, yellow, blue, pink, turquoise, white, Auto1: Red-green Auto2: Red-yellow-green
Lighting	Lighting time	0 s, 10 ... 600 s
Contrast	Contrast	15 ... 45
Bar chart	Bar chart display	yes, no

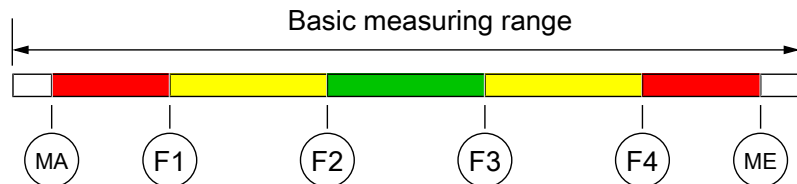

Illustration 11: Function Auto2

MA	MB-start	Measuring range start
F1	Red-Yell.switch.	Colour-change red to yellow
F2	Yell.-Gr.switch.	Colour-change yellow to green
F3	Gr.-Yell. switch	Colour-change green to yellow
F4	Yell.-Red switch	Colour-change yellow to red
ME	MB-end	Measuring range end

In this menu the same parameters are used as those described in the previous sections.

NOTICE

Unused range

If a range is not to be used, the associated switch thresholds (F1...F4) can be set to the same value.

Example

The parameter Colour is set to Auto2. Only the green, yellow and red ranges are required here. To fade out the lower ranges red and yellow, the switch thresholds "red-yellow switching" and "yellow-green switching" are set to the start of the measuring range.

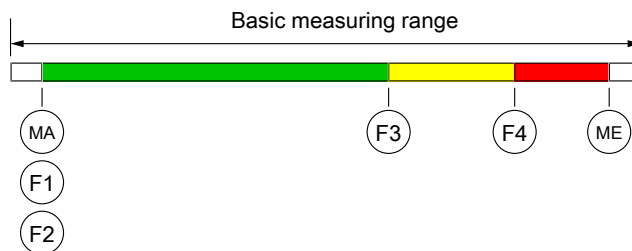

Illustration 12: Example Auto2

3.3.3.7 Menu Level System

Parameter name	Description	Value range
Language	Language change	DE, EN, FR, ES, IT,PT,HU

Parameter name	Description	Value range
Software Info	Information about the software	Device type, serial number, firmware version
Config. Info	Information about the configuration	Basic measuring range, output signal, contacts
Statistics	Statistics	Operating time, switch cycles of the contacts
Password	Password	0/1...999
Load config.	Load configuration	
Save config.	Save configuration	

The user menu can be switched to German, English, French, Spanish, Italian, Portuguese or Hungarian using the parameter **Language**.

The menu items **Software Info** and **Config. Info** provide information about the device. This information helps to answer questions about the device quickly.

- The serial number and the firmware version is shown in **Software info**. If a 'designation' has been assigned, this is also issued. Please note that a 'designation' can only be entered with the PC software by remote configuration.
- The basic measuring range, the defined output signal and existing contacts are stated in the **Config. Info**.

The **Statistics** provide information about the operating time and the relay switching cycles from the time of delivery. The operating time is shown in days (d) and hours (h)

A **Password** can be used to protect the menu against unauthorised access. The password is a figure from 1 to 999. The input 0 means that no password is active.

The password needs to be set if the user presses the button in normal mode to enter the menu. If a wrong password is entered, the system automatically jumps back to normal mode again. If no password is active, the display immediately jumps to the menu.

NOTICE

Forgotten password

The user cannot restore a forgotten password. Please contact the manufacturer in this case.

The user can load a saved configuration via the menu item **Load config**. This means that a functional set of parameters can be loaded after trying out various settings.

The menu item **Save config** serves to save the existing parameters in a protected memory area. This is helpful if the settings of a functional device needs to be optimised. **Save config** and **Load config** can be used to quickly restore the initial status again.

NOTICE

Delivery condition

If the user has not yet saved a configuration, the default values (status on delivery) are loaded. In this case, any measuring range spreads or switch points are reset and the device needs to be newly configured.

3.4 Technical data

3.4.1 Input variables

Measuring variable

Differential pressure for gas-like media

Measurement range	Pa
	0 ... 50
	0 ... 100
	0 ... 1000
	-20 ... +80
	-25 ... +25
	-50 ... +50
	-100 ... +100
	-150 ... +50
Static operating pressure	Max. 100 kPa
Bursting pressure	Max. 170 kPa

3.4.2 Output parameters

3.4.2.1 Analogue output

Output signal	0 ... 20 mA	
	4 ... 20 mA	
	0 ... 10 V	
Signal range	0,0 ... 21,0 mA	
	0,0 ... 11,0 V	
Apparent ohmic resistance	0/4 ... 20 mA	0 ... 10 V
	$U_b \leq 26 \text{ V}$ $R_L \leq (U_b - 4 \text{ V}) / 0,02 \text{ A}$	$R_L > 2 \text{ k}\Omega$
	$U_b > 26 \text{ V}$ $R_L \leq 1100$	

3.4.2.2 Switch output

2 potential-free semiconductor switches	(MOSFET)
Switching function (programmable)	One-pin activator (NO) One-pin deactivator (NC)
Switching voltage	3 ... 32 V AC/DC
Switching current	max. 0.25 A
Switching output	max. 8 W ($R_{on} \leq 4 \Omega$)

3.4.3 Measurement accuracy

Characteristic curve deviation*	(Non-linearity and hysteresis)	
	Maximum	1.0 % FS
	Typical	0.5 % FS
	Reproducibility	0.1 % FS
FS (Full Scale) refers to the basic measuring range. The information refers to a linear, nonspread characteristic curve at 25 °C and applies to all measuring ranges.		
Temperature coefficient	max. 0.6 % FS / 10 K	

In zero-point and span with reference to the basic measuring range (not spread), compensation range 4...50 °C.

3.4.4 Auxiliary energy

Rated Voltage	24 V AC/DC
----------------------	------------

Admissible operating voltage $U_b = 20 \dots 32 \text{ V AC/DC}$ **Power consumption**

approx. 2W (2VA)

Elektrischer Anschluss

Please see the supplied electro-technology documents for information about the electrical connection.

4 FT61 Humidity and temperature measuring device

4.1 Use as intended

This device is suitable for use as a display and switch device for measuring and monitoring the humidity and temperature in clean rooms and safety laboratories.

4.2 Design and mode of operation

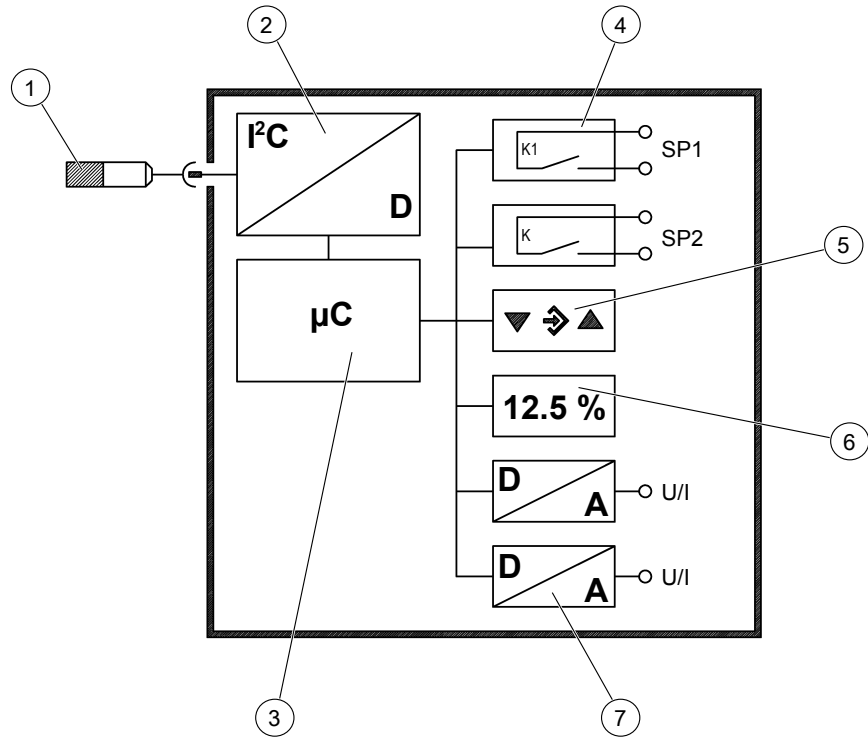

Illustration 13: Function diagram

1	Damp and temperature sensor	2	Signal conversion
3	Microcontroller	4	Switch output
5	Keyboard	6	Display
7	Analogue output		

The measuring device comprises a sensor and a display unit. The data measured on the sensor is transferred via I²C bus to the display.

This is where the data from the microprocessor-controlled electronics are converted into display, switch contacts and output signals.

4.3 User guide

The input channels of the FT61 are assigned as follows:

- Channel 1 : Relative humidity in %
- Channel 2: Temperature in °C

4.3.1 Display

4.3.1.1 Standard display

(a) 1 channel

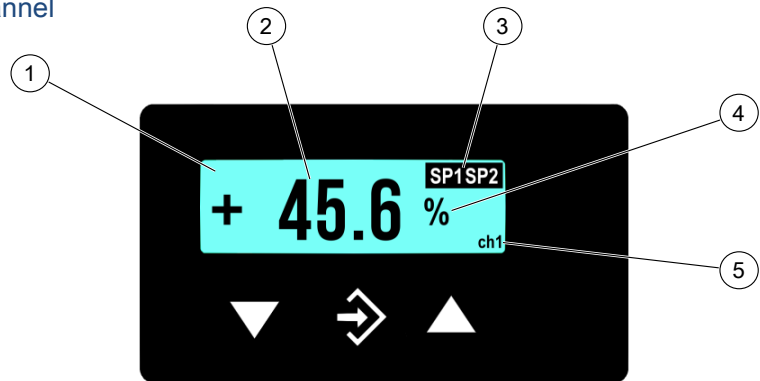

(b) 2 channel

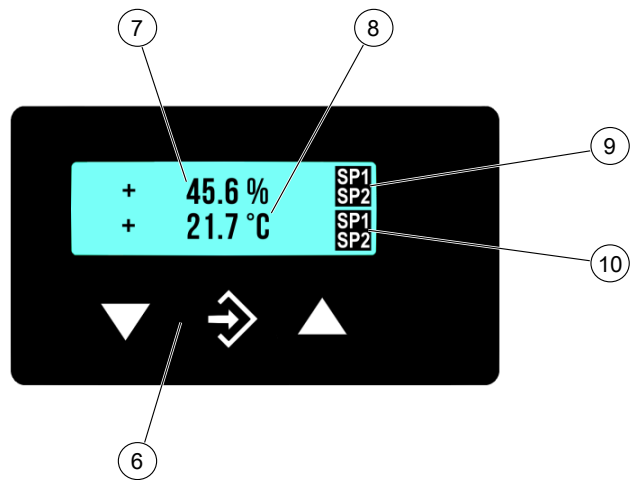

Illustration 14: Humidity/temperature display standard

1	LCD with back lighting	2	Measured Value Display
3	Status display of the switch points	4	Unit
5	Channel display ⁽¹⁾	6	Keyboard
7	Measured value channel 1	8	Measured value channel 2
9	Status display of the switch points for assignment channel 1 ⁽²⁾	10	Status display of the switch points for assignment channel 2 ⁽²⁾

(1) For easier differentiation, channel 2 is shown inverted: **ch2**.

(2) see parameter **Assignment SP**: [▶ 28]

4.3.1.2 Bar chart display

(a) 1 channel

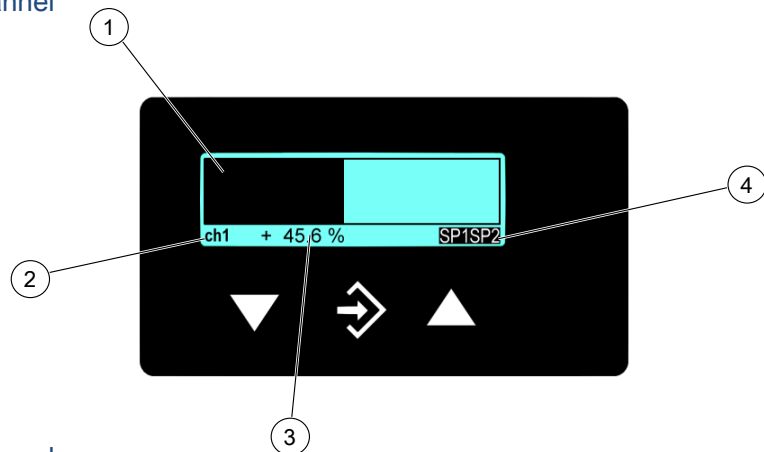

(b) 2 channel

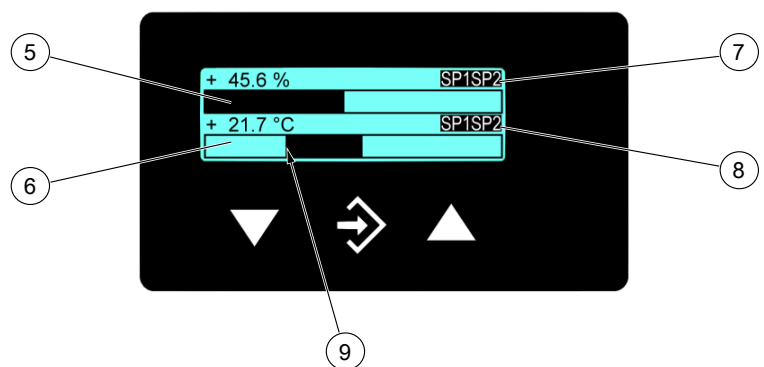

Illustration 15: Humidity/temperature display bar chart

1	Bar chart display	2	Channel display ⁽¹⁾
3	Measured Value Display	4	Status display of the switch points
5	Bar chart display channel 1	6	Bar chart display channel 2
7	Status display of the switch points for assignment channel 1 ⁽²⁾	8	Status display of the switch points for assignment channel 2 ⁽²⁾
9	Zero point of bar chart display		

(1) For easier differentiation, channel 2 is shown inverted: **ch2**.

(2) see parameter **Assignment SP**: [▶ 28]

In normal mode, the current measured value is shown on a 4-digit LC display. To show very large values, it is possible to switch to a 5 or 6-digit presentation (see Parameter **MB decimal place**).

SP1SP2

Illustration 16: LCD Switch points

The unit is shown on the right of the display. If the device is equipped with contacts, a closed contact is always symbolised by an inverted text "SP1" or "SP2". Various colours can be selected for the back lighting. Depending on the measured value, the colour of the back lighting can be automatically changed. This can be used e.g. to depict good/poor differences. The back lighting can also be deactivated.

The measured value can also be shown in a bar chart. The measured value is also shown in smaller pictures as a number.

During the programming, the menu items and the associated parameters are shown on the display. The device continues to function whilst the parameters are being set; apart from one exception, the changes come into effect instantly. The exception here is a change of switching times - here the previously valid time must have run down.

4.3.2 Keyboard

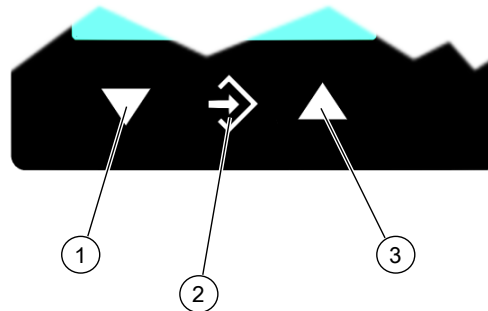

Illustration 17: Operating keys

1	Page down menu	Reduce value	
2	Call up menu	Save value	OK
3	Page up menu	Increase value	

The individual menu items and parameters can be displayed using the buttons ▲ and ▼. The respective menu item is selected or the parameters for making changes are called up via the button ⇨.

If a parameter can be changed, the display flashes. The change is made via the buttons ▲ and ▼. The value is saved with the button ⇨.

To leave a menu level or the entire menu, select the parameter "Quit" and press ⇨.

Example:

Switch-on point set switchpoint 1

In normal mode, press the button ⇨ to enter the menu. The menu level **Switch points** appears. Press the enter key ⇨ again to call up the display parameter.

The first parameter **Switch point 1 on** is displayed. To change this parameter, press the button ⇨ again.

The device jumps to the input:

- The parameter is stated in the 1st line.
- The value that is to be changed is shown in the 2nd line, the display flashes.
- The input limits are displayed in the 3rd line (if there is one).

The required value is set with the buttons ▲ and ▼ and then confirmed with ⇨.

4.3.3 Menu levels

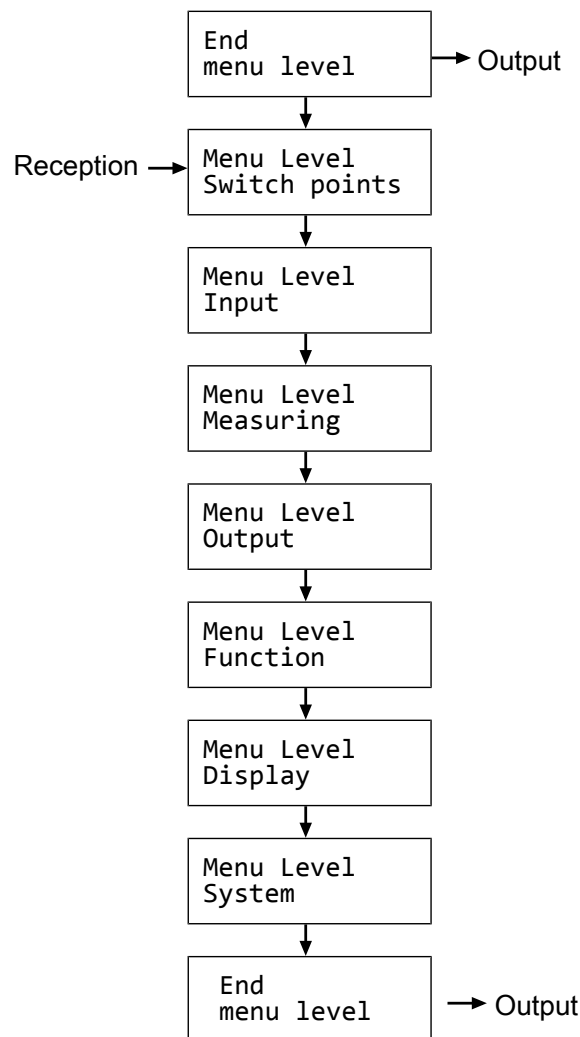

Illustration 18: Menu levels

4.3.3.1 Menu Level Switch points (2SP)

NOTICE! This menu only appears on models with two switching outputs.

Parameter name	Description	Value range
SP1 On	Switch point 1 On	MBA-50% ... MBE+50%
SP1 Off	Switching point 1 off	MBA-50% ... MBE+50%
SP1 Delay	Switching point 1 delay	0...1800 s
SP1 Function	Switching point 1 function	NO, NC
Assignment SP	Channel assignment	Channel 1, 2 and 1+2
SP2 On	Switch point 2 On	MBA-50% ... MBE+50%
SP2 Off	Switching point 2 off	MBA-50% ... MBE+50%
SP2 Delay	Switching point 2 delay	0...1800 s
SP2 Function	Switching point 2 function	NO, NC

The two switching outputs are configured by four parameters respectively. For the switch point 1 these are

- **SP1 On**
- **SP1 Off**

- **SP1 Delay**
- **SP1 Function**

Accordingly for switch point 2:

- **SP2 On**
- **SP2 Off**
- **SP2 Delay**
- **SP2 Function**

The function of the individual parameters is explained for both switch points using Switch point 1 as an example.

SP1 On defines the activation point, **SP1 Off** the deactivation point of switching output 1. The values are shown in the valid unit and set accordingly. The values are shown in the valid unit and set accordingly. Both parameters can be set independently over the entire value range.

The value range ranges from MBA – 50% to MBE + 50%. MBA stands for start of measuring range and MBE for the end of the measuring range.

Example:

Measuring range = 0 ... 100 %

The value range for this measuring range is -50 % ... +150 %.

Function of the switch points

Together, the two parameters **SP1 On** and **SP1 Off** determine the switch function of switching output 1:

- If **SP1 On** > **SP1 Off**, the output switches on, if the measured value exceeds SP1 On. It is only switched off again if the measured value SP1 Off is undercut (hysteresis function).
- If **SP1 On** = **SP1 Off**, the output switches on if the measured value exceeds SP1 On and off if the measured value undercuts the same value (SP1 Off).
- If **SP1 On** < **SP1 Off**, the output switches on, if the measured value lies within these switch points: i.e.:
SP1 On < Measured value < **SP1 Off** (window function).

SP1 Delay allows the reaction of the switching output to be delayed by between 0 and 1800 s. This parameter applies equally for switching on and off.

SP1 Function changes the function of the switching output 1. It is possible here to define whether the contact should work as a open contact (NO) or a break contact (NC).

Assignment SP is used to define the input to which the contacts are assigned. The following options are available:

- Channel 1
Both contacts are assigned to channel 1.
- Channel 1, channel 2
A contact is assigned to every channel.
Channel 1: SP1
Channel 2: SP2
- Channel 2
Both contacts are assigned to channel 2.

The unit and the input range are adapted accordingly when entering the switch points.

4.3.3.2 Menu Level Input

Channel 1:

Parameter name	Description	Value range
Absorption	Damping	0...100 s
Offset corr.	Offset correction	$\frac{1}{3}$ basic measuring range
Zero-pt. wind.	Zero-point window	$\frac{1}{3}$ basic measuring range

Channel 2:

Parameter name	Description	Value range
Absorption 2	Damping	0...100 s
Offset corr. 2	Offset correction	$\frac{1}{3}$ basic measuring range
Zero-pt. wind.2	Zero-point window	$\frac{1}{3}$ basic measuring range

The parameters for both channels are set in the same way. The following explains the parameters for the first channel as an example for both channels.

If there are unsteady measurement readings during operation, you can use the parameters **Damping** and **Zero-pt. wind.** to stabilise the reading (and the output signal).

The parameter **Absorption** functions like a capillary throttle. However, it only acts on the display, output signal and switch points (if these exist) but not on the measuring cell itself.

You can set the response time to measuring value jumps in the range 0.0 to 100 s.

NOTICE

Response time

At maximum damping it can take over 2 minutes until after a measurement jump from 100% to 0% is also shown as zero in the display.

In many cases, unsteady readings are not a problem during normal operating mode, but this is not true for the idle state, i.e. if a measured value of zero is expected. The parameter **Zero-pt. wind.** is designed to solve this. Its value defines a range around zero at which the measured value is set to zero (see fig.).

The display only stops showing zero when the measurement leaves the set window. When reaching double the value, the measured value and the reading match again. This avoids jumps in the display.

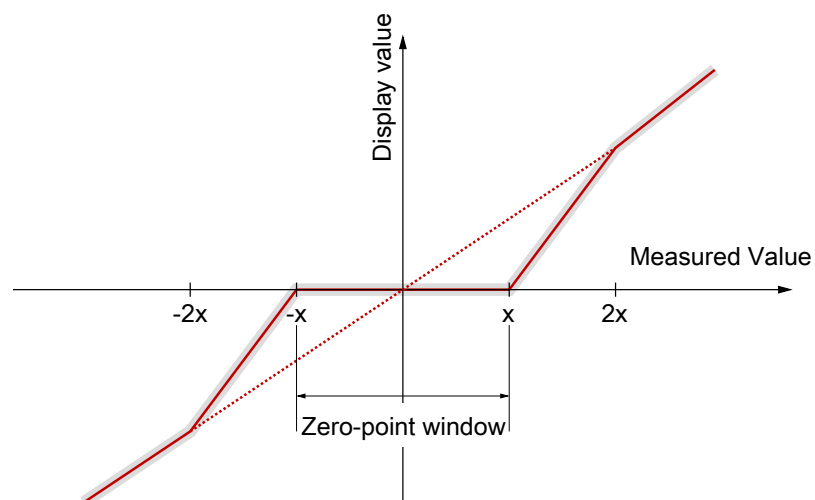

Illustration 19: Zero-point window

It may be necessary to set the offset to correct the impact of the installation position.

Select the **Offset corr.** parameter and correct the reading using the buttons ▲ or ▼ until zero is shown in the display.

When setting the offset, the current measured value is displayed. The zero-point window is not active during the offset setting.

4.3.3.3 Menu Level Measurement

Channel 1:

Parameter name	Description	Value range
MB start	Measuring range start	Basic measuring range
MB end	Measuring range end	Basic measuring range
Unit	Measuring range unit	
Limit	Measuring range limit	yes, no

Channel 2:

Parameter name	Description	Value range
MB 2 start	Measuring range start	Basic measuring range
MB 2 end	Measuring range end	Basic measuring range
Unit 2	Measuring range unit	

The output signals of the transmitter primarily depend on the measured input variables (channel 1 or channel 2). However, you have the option of adjusting the output signals to a large extent to suit your requirements.

The two channels are configured by three parameters respectively. The 2nd channel is configured analogue to the first channel. The settings are identical for both channels and are explained in the following using channel 1 as an example.

NOTICE

Adjustment of the output signal

The basic measuring range (indicated on the type label) and the type of output signal (voltage / current) are not variable.

The parameters **MB start** and **MB end** initially define the two measurements between which the output signal will change at all. Both values are adjustable across the entire basic measuring range. The set values also refer to the measurement in the respective unit. However, the signal values (current / voltage) for Start of measuring range and End of measuring range are fixed.

If **MB start** is smaller than **MB end**, this is called an increasing characteristic curve; the output signal increases as the measurement increases.

If **MB end** is smaller than **MB start**, this is a decreasing characteristic curve and the output signal decreases as the measurement increases.

The difference between the values **MB start** and **MB end** must be at least 25 % of the basic measuring range.

You can select a unit other than the unit of the basic measuring range with the parameter **Unit**. The user should remember however that not every unit is suitable. The conversion is automatic.

The parameter **Limit** allows the display, output and switching points to be limited to the range between Start of measuring range and End of measuring range. If Limit is set to "no", those measured values that are greater or smaller than the end values are shown.

4.3.3.4 Menu Level Output

There are two output signals available that are permanently assigned to the respective input channels. The type of output signal (0/4...20 mA, 0...10V) must be stated on the order and cannot be changed.

Both outputs are configured in the same way, which is why this is only explained for the first output.

Output 1 (→channel 1)

Parameter name	Description	Value range
min. output	min. output	
max. output	max. output	0.0 ... 21.0 mA or 0.0 ... 11.0 V
Error signal	Measuring range unit	

Output 2 (→channel 2)

Parameter name	Description	Value range
min. output 2	min. output	
max. output 2	max. output	0.0 ... 21.0 mA or 0.0 ... 11.0 V
Error signal 2	Measuring range unit	

The parameters **min. output**, **max. output** and **error signal** define the limits of the output signal that may not be undercut or exceeded regardless of the measured variable. The limit values take priority over the range defined by the **Start of measuring range** and **End of measuring range** parameters! These parameters primarily serve to prevent error messages in downstream systems caused by brief overstepping of measuring ranges.

The parameter **Min. output** is usually only used for devices with an output signal 4...20 mA because frequently values of below 3.8 mA are evaluated as error signals.

The **Max. output** value can be used for the voltage and current to limit the maximum value.

The value defined via the parameter **Error signal** is issued if the device detects an internal error and can no longer work correctly. It should be noted here that not all potential errors and faults can be detected by the device itself.

4.3.3.5 Menu Level Function

The Function menu level is deactivated for this device. The input signal of both channels is transferred to the display and output with a linear function.

4.3.3.6 Menu Level Display

The Display menu level is a variable menu whose appearance depends on the value of the colour parameter. In addition to the various colours for the background lighting, there are also two auto-functions with colour switching available.

Parameter name	Description	Value range
Colour	Colour	Off, red, green, yellow, blue, pink, turquoise, white, Auto1: Red-green Auto2: Red-yellow-green
Lighting	Lighting time	0 s, 10 ... 600 s
Contrast	Contrast	15 ... 45
Bar chart	Bar chart display	yes, no

The most important parameter is **Colour**. A fixed colour can be defined for the background colour here. There are also two auto-functions with colour switching available. Alternatively, the background illumination can be permanently deactivated.

If permanent lighting is not required, the parameter **Lighting time** can be used to define when the lighting should be switched off after the last time a button is pressed. In addition to permanent lighting (0 s), automatic shut-down after 10... 600 s is also possible. The set time is only valid if the parameter **Colour** is not set to "off".

Amongst other things, the legibility of the display depends on the temperature and the reading angle. To ensure optimised legibility, the display can be adjusted using the parameter **Contrast**. When the contrast is changed, it is possible that the display appears empty or almost completely black. In this case, the contrast must be turned up or down.

Via the parameter **Bar chart**, the display can be switched between a display where the measured value is either shown in large digits or the display shows small digits and an additional barchart.

Auto1: Colour-change red to green

In the mode with the automatic colour switchover, it is possible to enter the required switch thresholds "red-green switchover", "green-red switchover".

The switching thresholds can be moved within the measuring range. The series of switch points cannot be altered.

Parameter name	Description	Value range
Red-Gr. switch.	Red-green switching	MRS - 50% ...
Gr-Red switch.	Green-red switching	MRE + 50%
Hysteresis	Hysteresis	0.1 ... 10.0 %
Delay	Delay	0 ... 1800 s
Colour	Colour	Off, red, green, yellow, blue, pink, turquoise, white, Auto1: Red-green Auto2: Red-yellow-green
Lighting	Lighting time	0 s, 10 ... 600 s
Contrast	Contrast	15 ... 45
Bar chart	Barchart display	yes, no

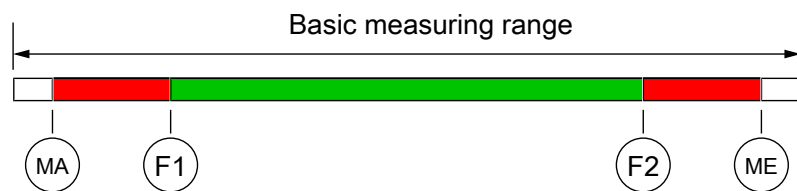

Illustration 20: Function Auto1

MA	MB-start	Measuring range start
F1	Red-Gr. switch.	Red-green switching
F2	Gr-Red switch.	Green-red switching
ME	MB-end	Measuring range end

The parameter **Hysteresis** can be used to prevent fast and unwanted colour changes. The hysteresis is set in the range 0.1... 10%.

NOTICE

Overlapping colour areas

Note: In the case of large hysteresis values, steps must be taken to ensure that the ranges of the individual colours do not overlap. Otherwise it is possible that the colour change may not function in the desired way.

The parameter **Delay** offers a further option to prevent unwanted colour changes. The colour change here can be delayed between 0...1800 s.

The parameter **Lighting** can be used to define when the lighting should be switched off after the last time a button is pressed. In addition to permanent lighting, automatic shut-down after 10...600 s is also possible. The set time is only valid if the parameter **Colour** is not set to "off". The lighting can be switched on permanently with the value 0s.

The legibility of the display can be adjusted using the parameter **Contrast**. When the contrast is changed, it is possible that the display appears empty or almost completely black. In this case, the contrast must be turned up or down again.

Via the parameter **Bar chart**, the display can be switched between a display where the measured value is either shown in large digits or the display shows small digits and an additional barchart.

Auto2: Colour-change red-yellow-green

In the Auto 2 mode with the automatic colour switchover, it is possible to enter the required switch thresholds "red-yellow switchover", "yellow-green switchover", "green-yellow switchover", "yellow-red switchover".

The switching thresholds can be moved within the measuring range. The series of switch points cannot be altered.

Parameter name	Description	Value range
Red-Yell.switch.	Red-yellow switchover	MRS - 50% ... MRE + 50%
Yell.-Gr.switch.	Yellow-green switchover	
Gr.-Yell. switch	Green-yellow switchover	
Yell.-Red switch	Yellow-red switchover	
Hysteresis	Hysteresis	0.1 ... 10.0 %
Delay	Delay	0 ... 1800 s
Colour	Colour	Off, red, green, yellow, blue, pink, turquoise, white, Auto1: Red-green Auto2: Red-yellow-green
Lighting	Lighting time	0 s, 10 ... 600 s
Contrast	Contrast	15 ... 45
Bar chart	Barchart display	yes, no

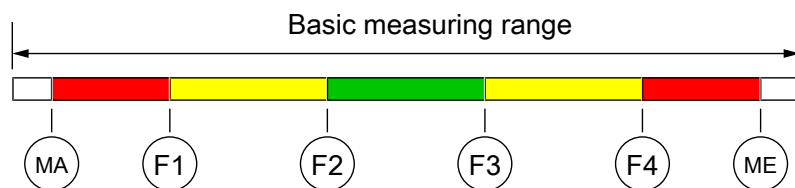

Illustration 21: Function Auto2

MA	MB-start	Measuring range start
F1	Red-Yell.switch.	Colour-change red to yellow
F2	Yell.-Gr.switch.	Colour-change yellow to green
F3	Gr.-Yell. switch	Colour-change green to yellow
F4	Yell.-Red switch	Colour-change yellow to red
ME	MB-end	Measuring range end

In this menu the same parameters are used as those described in the previous sections.

NOTICE

Unused range

If a range is not to be used, the associated switch thresholds (F1...F4) can be set to the same value.

Example

The parameter Colour is set to Auto2. Only the green, yellow and red ranges are required here. To fade out the lower ranges red and yellow, the switch thresholds "red-yellow switching" and "yellow-green switching" are set to the start of the measuring range.

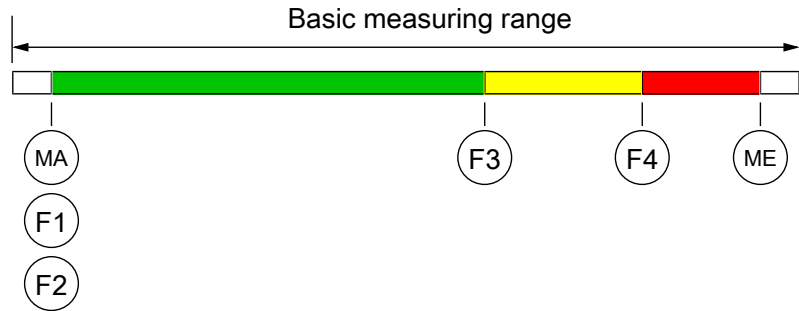

Illustration 22: Example Auto2

4.3.3.7 Menu Level System

Parameter name	Description	Value range
Language	Language change	DE, EN, FR, ES, IT,PT,HU
Software Info	Information about the software	Device type, serial number, firmware version
Config. Info	Information about the configuration	Basic measuring range, output signal, contacts
Statistics	Statistics	Operating time, switch cycles of the contacts
Password	Password	0/1...999
Load config.	Load configuration	
Save config.	Save configuration	

The user menu can be switched to German, English, French, Spanish, Italian, Portuguese or Hungarian using the parameter **Language**.

The menu items **Software Info** and **Config. Info** provide information about the device. This information helps to answer questions about the device quickly.

- The serial number and the firmware version is shown in **Software info**. If a 'designation' has been assigned, this is also issued. Please note that a 'designation' can only be entered with the PC software by remote configuration.
- The basic measuring range, the defined output signal and existing contacts are stated in the **Config. Info**.

The **Statistics** provide information about the operating time and the relay switching cycles from the time of delivery. The operating time is shown in days (d) and hours (h)

A **Password** can be used to protect the menu against unauthorised access. The password is a figure from 1 to 999. The input 0 means that no password is active.

The password needs to be set if the user presses the button in normal mode to enter the menu. If a wrong password is entered, the system automatically jumps back to normal mode again. If no password is active, the display immediately jumps to the menu.

NOTICE

Forgotten password

The user cannot restore a forgotten password. Please contact the manufacturer in this case.

The user can load a saved configuration via the menu item **Load config**. This means that a functional set of parameters can be loaded after trying out various settings.

The menu item **Save config** serves to save the existing parameters in a protected memory area. This is helpful if the settings of a functional device needs to be optimised. **Save config** and **Load config** can be used to quickly restore the initial status again.

NOTICE

Delivery condition

If the user has not yet saved a configuration, the default values (status on delivery) are loaded. In this case, any measuring range spreads or switch points are reset and the device needs to be newly configured.

4.4 Technical data

4.4.1 Input variables

Measuring variable

Humidity and temperature of gaseous media.

Measuring ranges

	Precision	Long term drift
0 ... 100 % RH	±3 % RH	< 0,04 °C/year
-40 ... 100 °C	±0,5 °C	< 0,5 % RH/year

4.4.2 Output parameters

Output signal

The device has two analogue outputs (% rel. hum., °C) with the following signals:

0 ... 20 mA
4 ... 20 mA
0 ... 10 V

Apparent ohmic resistance

0/4 ... 20 mA	0 ... 10 V
$U_b \leq 26 \text{ V}$ $R_L \leq (U_b - 4 \text{ V}) / 0,02 \text{ A}$	$R_L > 2 \text{ k}\Omega$
$U_b > 26 \text{ V}$ $R_L \leq 1100$	

Switch output

2 potential-free semiconductor switches	(MOSFET)
Switching function (programmable)	One-pin activator (NO) One-pin deactivator (NC)
Switching voltage	3 ... 32 V AC/DC
Switching current	max. 0.25 A
Switching output	max. 8 W ($R_{on} \leq 4 \Omega$)

4.4.3 Measurement accuracy

**Measurement deviation %
rel. hum.**

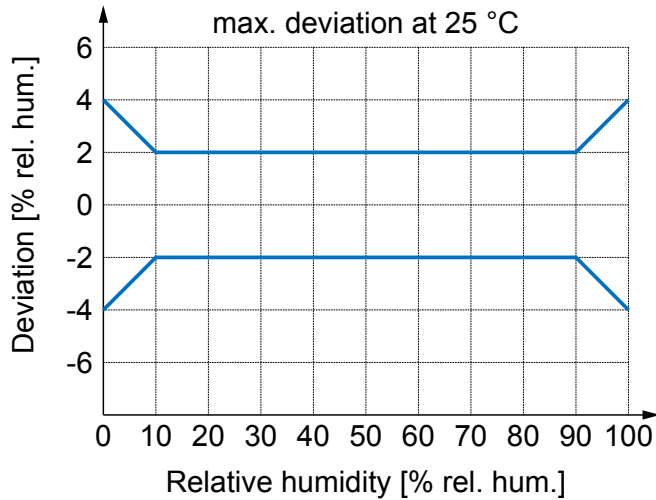

Illustration 23: Measurement accuracy [% rel. hum.]

Measurement deviation °C

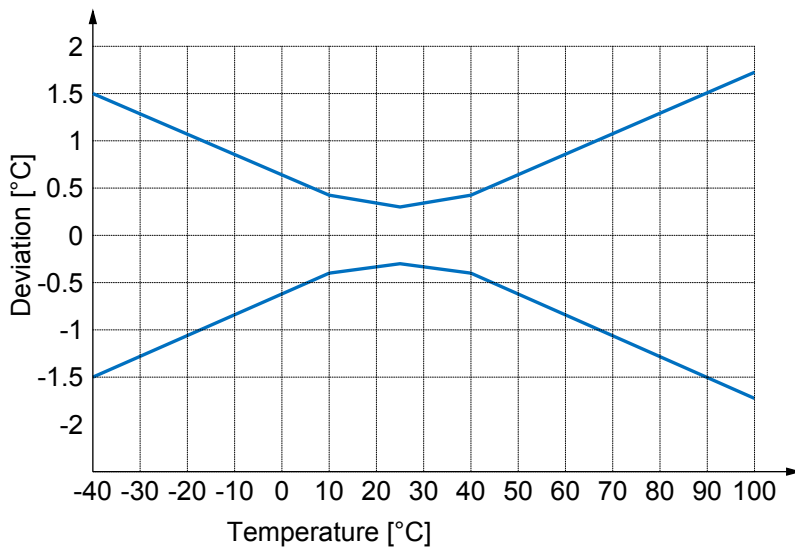

Illustration 24: Measurement accuracy [°C]

4.4.4 Auxiliary energy

Rated Voltage

24 V AC/DC

**Admissible operating
voltage**

$U_b = 20 \dots 32 \text{ V AC/DC}$

Power consumption

approx. 2W (2VA)

Elektrischer Anschluss

Please see the supplied electro-technology documents for information about the electrical connection.

5 EA14 Universal display

5.1 Use as intended

This device is suitable for use as a display and switch device for transmitters with unit signals 0/4 ... 20 mA or 0 ... 10 V. It can be used for measuring and monitoring critical operating parameters of clean rooms and safety laboratories.

5.2 Design and mode of operation

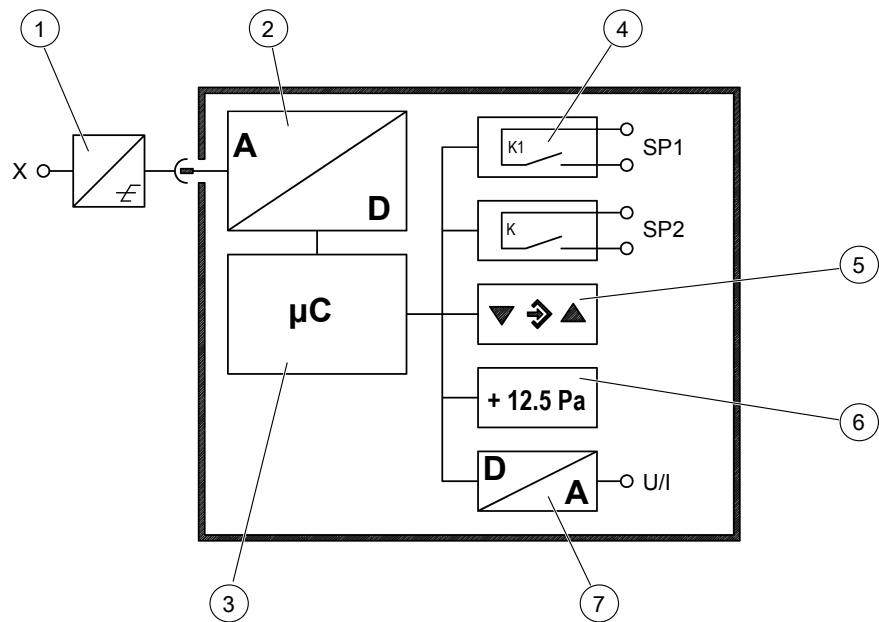

Illustration 25: Function diagram

1	Transmitter with input signal	2	Signal conversion
3	Microcontroller	4	Switch output
5	Keyboard	6	Display
7	Analogue output		

This device is based on an electronic analysis switch that analyses the measuring signal of an external transmitter. The main task is to display and analyse the measured signal. Optionally, an output signal can be provided that is proportional to the input signal.

5.3 User guide

5.3.1 Display

(a) Standard display

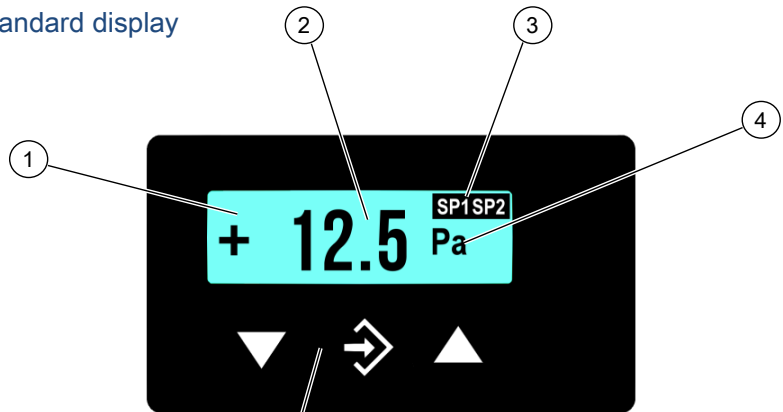

(b) Bar chart display

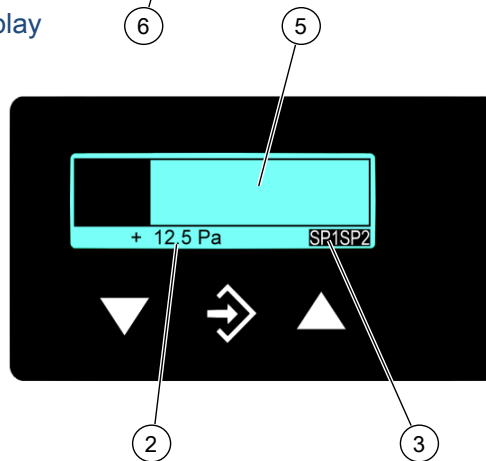

Illustration 26: Room pressure display

1	LCD with back lighting	2	Measured Value Display
3	Status display of the switch points	4	Unit
5	Bar chart display	6	Keyboard

In normal mode, the current measured value is shown on a 4-digit LC display. To show very large values, it is possible to switch to a 5 or 6-digit presentation (see Parameter **MB decimal place**).

SP1SP2

Illustration 27: LCD Switch points

The unit is shown on the right of the display. If the device is equipped with contacts, a closed contact is always symbolised by an inverted text "SP1" or "SP2".

Various colours can be selected for the back lighting. Depending on the measured value, the colour of the back lighting can be automatically changed. This can be used e.g. to depict good/poor differences. The back lighting can also be deactivated.

The measured value can also be shown in a bar chart. The measured value is also shown in smaller pictures as a number.

During the programming, the menu items and the associated parameters are shown on the display. The device continues to function whilst the parameters are being set; apart from one exception, the changes come into effect instantly. The exception here is a change of switching times - here the previously valid time must have run down.

5.3.2 Keyboard

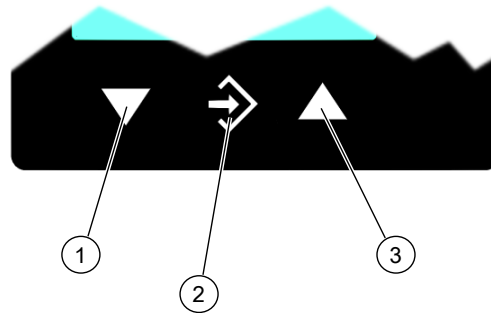

Illustration 28: Operating keys

1	Page down menu	Reduce value	
2	Call up menu	Save value	OK
3	Page up menu	Increase value	

The individual menu items and parameters can be displayed using the buttons ▲ and ▼. The respective menu item is selected or the parameters for making changes are called up via the button ⇨.

If a parameter can be changed, the display flashes. The change is made via the buttons ▲ and ▼. The value is saved with the button ⇨.

To leave a menu level or the entire menu, select the parameter "Quit" and press ⇨.

Example:

Switch-on point set switchpoint 1

In normal mode, press the button ⇨ to enter the menu. The **menu level Switch points** appears. Press the enter key ⇨ again to call up the display parameter.

The first parameter **Switch point 1 on** is displayed. To change this parameter, press the button ⇨ again.

The device jumps to the input:

- The parameter is stated in the 1st line.
- The value that is to be changed is shown in the 2nd line, the display flashes.
- The input limits are displayed in the 3rd line (if there is one).

The required value is set with the buttons ▲ and ▼ and then confirmed with ⇨.

5.3.3 Menu levels

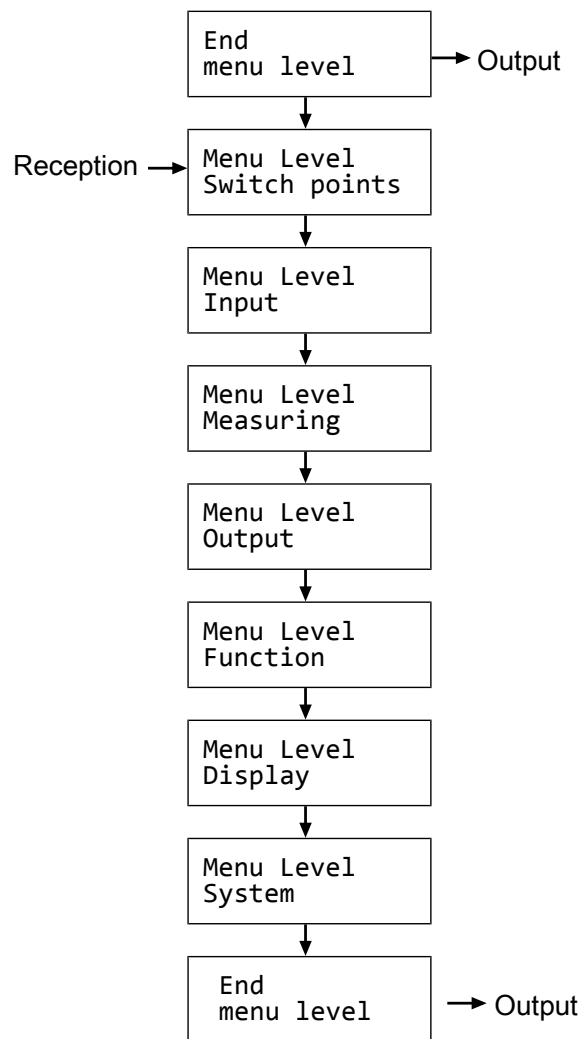

Illustration 29: Menu levels

5.3.3.1 Menu Level Switch points

Parameter name	Description	Value range
SP1 On	Switch point 1 On	MRS-50% ... MRE+50%
SP1 Off	Switching point 1 off	MRS-50% ... MRE+50%
SP1 Delay	Switching point 1 delay	0...1800 s
SP1 Function	Switching point 1 function	NO, NC
SP2 On	Switch point 2 On	MRS-50% ... MRE+50%
SP2 Off	Switching point 2 off	MRS-50% ... MRE+50%
SP2 Delay	Switching point 2 delay	0...1800 s
SP2 Function	Switching point 2 function	NO, NC

The two switch outputs are configured by four parameters respectively. For the switch point 1 these are

- **SP1 On**
- **SP1 Off**
- **SP1 Delay**
- **SP1 Function**

Accordingly for switch point 2:

- **SP2 On**
- **SP2 Off**
- **SP2 Delay**
- **SP2 Function**

The function of the individual parameters is explained for both switch points using Switch point 1 as an example.

SP1 On defines the activation point, **SP1 Off** the deactivation point of switch output 1. The values are shown in the valid unit and set accordingly. The values are shown in the valid unit and set accordingly. Both parameters can be set independently over the entire value range.

The value range ranges from MRS – 50% to MRE + 50%. MRS stands for measuring range start and MRE for measuring range end.

Example:

Measurement range = 0 ... 100 Pa

The value range for this measuring range is -50 Pa ... +150 Pa.

Together, the two parameters **SP1 On** and **SP1 Off** determine the switch function of switch output 1:

- If **SP1 On** > **SP1 Off**, the output switches on, if the measured value exceeds SP1 On. It is only switched off again if the measured value SP1 Off is undercut (hysteresis function).
- If **SP1 On** = **SP1 Off**, the output switches on if the measured value exceeds SP1 On and off if the measured value undercuts the same value (SP1 Off).
- If **SP1 On** < **SP1 Off**, the output switches on, if the measured value lies within these switch points: i.e:
SP1 On < Measured value < **SP1 Off** (window function).

SP1 Delay allows the reaction of the switch output to be delayed by between 0 and 1800 s. This parameter applies equally for switching on and off.

SP1 Function changes the function of the switch output 1. It is possible here to define whether the contact should work as a open contact (NO) or a break contact (NC).

5.3.3.2 Menu Level Input

Parameter name	Description	Value range
Attenuation	Attenuation	0...100 s
Offset correction	Offset correction	1/3 basic measuring range
Zero-point window	Zero-point window	1/3 basic measuring range

If there are unsteady measurement readings during operation, you can use the parameters **Damping** and **Zero-point window** to stabilise the reading and the output signal.

The parameter **Damping** functions like a capillary throttle. However, it only acts on the display, output signal and switch points (if these exist) but not on the measuring cell itself.

You can set the response time to measuring value jumps in the range 0.0 to 100 s.

NOTICE

Response time

At maximum damping it can take over 2 minutes until after a measurement jump from 100% to 0% is also shown as zero in the display.

In many cases, unsteady readings are not a problem during normal operating mode, but this is not true for the idle state, i.e. if a measured value of zero is expected. The parameter **Zero-point window** is designed to solve this. Its value defines a range around zero at which the measured value is set to zero (see fig.).

The display only stops showing zero when the measurement leaves the set window. When twice the window value is reached, the measuring pressure and the display correspond again. This avoids jumps in the display.

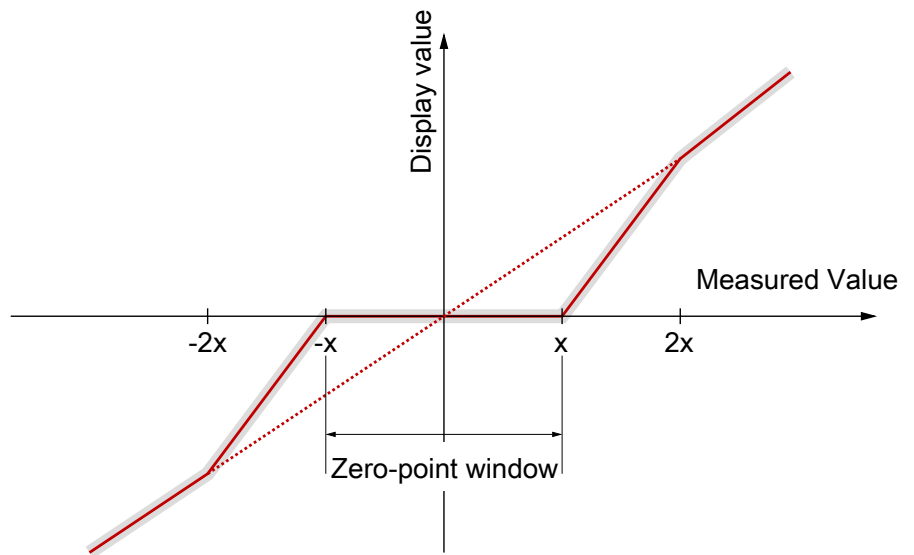

Illustration 30: Zero-point window

It may make sense to set the offset, if the displayed value needs to be matched to another display.

Select the **Offset correction** parameter and correct the reading using the buttons ▲ or ▼ until zero is shown in the display.

When setting the offset, the current measured value is displayed. The zero-point window is not active during the offset setting.

5.3.3.3 Menu Level Measuring

Parameter name	Description	Value range
MB start	Measuring range start	Basic measuring range
MB end	Measuring range end	Basic measuring range
Unit	Measuring range unit	bar, mbar, Pa, kPa, MPa, psi, InWc, mmWs, mmHg
Limit	Measuring range limit	yes, no

The transmitter output signal primarily depends on the sensed pressure. However, you have the option of adjusting the output signal to a large extent to suit your requirements.

NOTICE

Adjustment of the output signal

The basic measuring range (indicated on the type label) and the type of output signal (voltage / current) are not variable.

The parameters **MB start** and **MB end** initially define the two pressures between which the output signal will change at all. Both values are adjustable across the entire basic measuring range. The set values also refer to the pressure in the respective unit. However, the signal values (current / voltage) for 'Start of measuring range' and 'End of measuring range' are fixed.

If **MB start** is smaller than **MB end**, this is called an increasing characteristic curve; the output signal increases as the pressure increases.

If **MB end** is smaller than **MB start**, this is a decreasing characteristic curve and the output signal decreases as the pressure increases.

The difference between the values **MB start** and **MB end** must be at least 25 % of the basic measuring range.

You can select a unit other than the unit of the basic measuring range with the parameter **Unit**. The user should remember however that not every unit is suitable. The conversion is automatic.

The parameter **Limit** allows the display, output and switching points to be limited to the range between Start of measuring range and End of measuring range. This makes sense when content is measured to avoid "negative contents". If Limit is set to "no", those measured values that are greater or smaller than the end values are shown.

5.3.3.4 Menu Level Output

Parameter name	Description	Value range
min. output	min. output	
max. output	max. output	0.0 ... 21.0 mA or 0.0 ... 11.0 V
Error signal	Measuring range unit	

The parameters **min. output**, **max. output** and **error signal** define the limits of the output signal that may not be undercut or exceeded regardless of the measured variable. The limit values take priority over the range defined by the **Start of measuring range** and **End of measuring range** parameters! These parameters primarily serve to prevent error messages in downstream systems caused by brief overstepping of measuring ranges.

The parameter **Min. output** is usually only used for devices with an output signal 4...20 mA because frequently values of below 3.8 mA are evaluated as error signals.

The **Max. output** value can be used for the voltage and current to limit the maximum value.

The value defined via the parameter **Error signal** is issued if the device detects an internal error and can no longer work correctly. It should be noted here that not all potential errors and faults can be detected by the device itself.

5.3.3.5 Menu Level Function

The Function menu level is a variable menu whose appearance depends on the value of the Function parameter. There are linear, square rooted and table functions

Linear function

The input signal is linear before being sent to the display and the output. The range defined in the menu "Measuring" serves as the measuring range. If the function LINEAR is active, the other menu items are cancelled.

Parameter name	Description	Value range
Function	Function	Value = linear

Square rooted function

Here, the input signal is square rooted before being sent to the display and the output. A free unit can be defined for the display. To do this, the start and end of the display range and the number of decimal points are defined. It is also possible to define the unit with 4 characters.

Parameter name	Description	Value range
Function	Function	Value = square rooted
Decimal place MB	Measuring range decimal places	1234, 123.4, 12.34, 1,234, 12345, 123456
MB-start	Measuring range start	-9999 ... +9999
MB-end	Measuring range end	-9999 ... +9999
Unit MB	Measuring range unit	4 characters

The following section contains descriptions of the parameters **Measuring range decimal place**, **MB start**, **MB end** and **unit MB** to describe the table function.

Tables function

This function allows free adjustment of the input variable to the display and output via a table with up to 30 support points. A value pair comprising a measured value and display value is issued for every support point.

NOTICE

Change of parameter

When switching from TABLE to another function, the table is initialised again and the existing values are lost.

Parameter name	Description	Value range
Function	Function	Value = Table
MB decimal pl.	Measuring range decimal places	1234, 123.4, 12.34, 1,234, 12345, 123456
MB start	Measuring range start	-9999 ... +9999
MB end	Measuring range end	-9999 ... +9999
MB unit	Measuring range unit	4 characters
No. of pairs	Number of pairs	n = 3...30
Value pair1	Value pair 1	MB-start ... MB-end
Value pair2	Value pair 2	
Value pair3	Value pair 3	
	...	
Value pair30	Value pair 30	

The display range is defined with the parameters **MB decimal pl.**, **MB start** and **MB end**. The user can select the configuration freely.

Using the parameter **MB decimal pl.**, it is possible to select between a 5 or 6-digit presentation. The resolution is not increased. Only an extra zero or two zeros are added. This serves the correct display of larger values. The measuring range must be positive for the 6 digit presentation.

The **MB unit** gives the user the option of defining a completely independent unit. Letters, numbers or special characters can be used. The unit can be max. 4 characters long.

If the function TABLE is selected, then it is also necessary to state the **No. of pairs**. It is defined here how many pairs of values (support points) are used in the table. A table is made up of at least 3, max. 30 support points.

NOTICE

Number of value pairs

If the number of value pairs is changed, the table is initialised again and the existing values are deleted.

Value pair	2
+14,6 mbar	+8,6 %
+0,0 ... +100,0 mbar	

- 1 input mark (value flashes)
2 allowed range of values

Illustration 31: Value pair

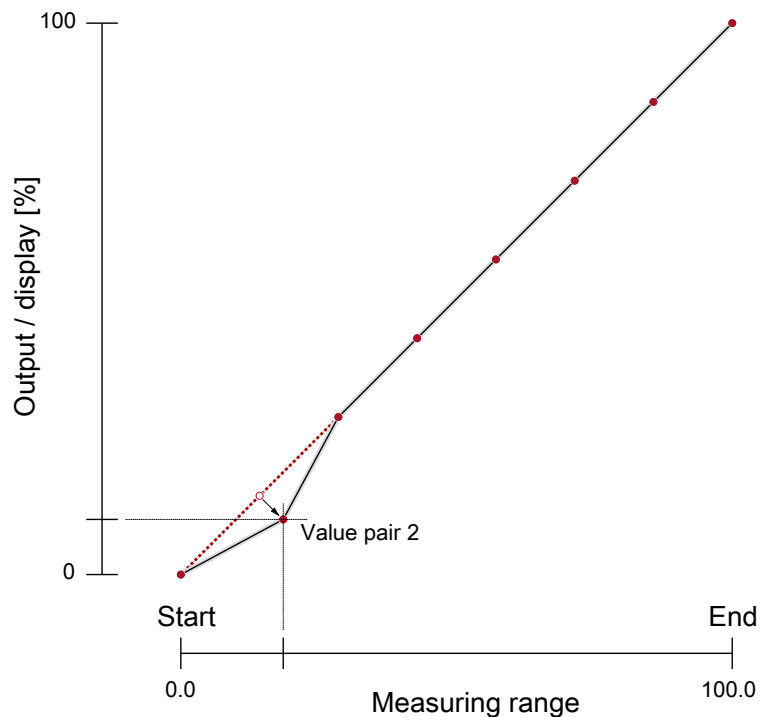

Illustration 32: Table function (example)

The individual value pairs can be seen and changed with the **Value pair1** to **Value pair30** parameters. A value pair comprises a measured value (left side) and a display value (right side). The measured value must lie within the measuring range and the display value must lie within the defined "free unit". The respective limits are shown during input. The table must contain either increasing or decreasing values. the table must contain either continuously increasing or continuously failing values. A change from an increasing to a decreasing characteristic curve within a support point table is not allowed.

5.3.3.6 Menu Level Display

The Display menu level is a variable menu whose appearance depends on the value of the colour parameter. In addition to the various colours for the background lighting, there are also two auto-functions with colour switching available.

Parameter name	Description	Value range
Colour	Colour	Off, red, green, yellow, blue, pink, turquoise, white, Auto1: Red-green Auto2: Red-yellow-green
Lighting	Lighting time	0 s, 10 ... 600 s
Contrast	Contrast	15 ... 45
Bar chart	Barchart display	yes, no

The most important parameter is **Colour**. A fixed colour can be defined for the background colour here. There are also two auto-functions with colour switching available. Alternatively, the background illumination can be permanently deactivated.

If permanent lighting is not required, the parameter **Lighting time** can be used to define when the lighting should be switched off after the last time a button is pressed. In addition to permanent lighting (0 s), automatic shut-down after 10... 600 s is also possible. The set time is only valid if the parameter **Colour** is not set to "off".

Amongst other things, the legibility of the display depends on the temperature and the reading angle. To ensure optimised legibility, the display can be adjusted using the parameter **Contrast**. When the contrast is changed, it is possible that the display appears empty or almost completely black. In this case, the contrast must be turned up or down.

Via the parameter **Bar chart**, the display can be switched between a display where the measured value is either shown in large digits or the display shows small digits and an additional barchart.

Auto1: Colour-change red to green

In the mode with the automatic colour switchover, it is possible to enter the required switch thresholds "red-green switchover", "green-red switchover".

The switching thresholds can be moved within the measuring range. The series of switch points cannot be altered.

Parameter name	Description	Value range
Red-Gr. switch.	Red-green switching	MRS - 50% ...
Gr-Red switch.	Green-red switching	MRE + 50%
Hysteresis	Hysteresis	0.1 ... 10.0 %
Delay	Delay	0 ... 1800 s
Colour	Colour	Off, red, green, yellow, blue, pink, turquoise, white, Auto1: Red-green Auto2: Red-yellow-green
Lighting	Lighting time	0 s, 10 ... 600 s
Contrast	Contrast	15 ... 45
Bar chart	Barchart display	yes, no

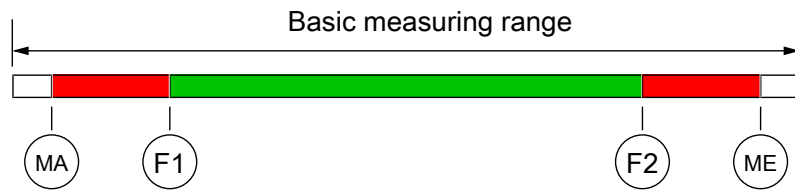

Illustration 33: Function Auto1

MA	MB-start	Measuring range start
F1	Red-Gr. switch.	Red-green switching
F2	Gr-Red switch.	Green-red switching
ME	MB-end	Measuring range end

The parameter **Hysteresis** can be used to prevent fast and unwanted colour changes. The hysteresis is set in the range 0.1... 10%.

NOTICE

Overlapping colour areas

Note: In the case of large hysteresis values, steps must be taken to ensure that the ranges of the individual colours do not overlap. Otherwise it is possible that the colour change may not function in the desired way.

The parameter **Delay** offers a further option to prevent unwanted colour changes. The colour change here can be delayed between 0... 1800 s.

The parameter **Lighting** can be used to define when the lighting should be switched off after the last time a button is pressed. In addition to permanent lighting, automatic shut-down after 10...600 s is also possible. The set time is only valid if the parameter **Colour** is not set to "off". The lighting can be switched on permanently with the value 0s.

The legibility of the display can be adjusted using the parameter **Contrast**. When the contrast is changed, it is possible that the display appears empty or almost completely black. In this case, the contrast must be turned up or down again.

Via the parameter **Bar chart**, the display can be switched between a display where the measured value is either shown in large digits or the display shows small digits and an additional barchart.

Auto2: Colour-change red-yellow-green

In the Auto 2 mode with the automatic colour switchover, it is possible to enter the required switch thresholds "red-yellow switchover", "yellow-green switchover", "green-yellow switchover", "yellow-red switchover".

The switching thresholds can be moved within the measuring range. The series of switch points cannot be altered.

Parameter name	Description	Value range
Red-Yell.switch.	Red-yellow switchover	MRS - 50% ... MRE + 50%
Yell.-Gr.switch.	Yellow-green switchover	
Gr.-Yell. switch	Green-yellow switchover	
Yell.-Red switch	Yellow-red switchover	
Hysteresis	Hysteresis	0.1 ... 10.0 %
Delay	Delay	0 ... 1800 s

Parameter name	Description	Value range
Colour	Colour	Off, red, green, yellow, blue, pink, turquoise, white, Auto1: Red-green Auto2: Red-yellow-green
Lighting	Lighting time	0 s, 10 ... 600 s
Contrast	Contrast	15 ... 45
Bar chart	Barchart display	yes, no

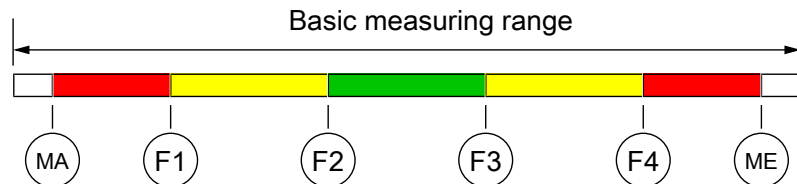

Illustration 34: Function Auto2

MA	MB-start	Measuring range start
F1	Red-Yell.switch.	Colour-change red to yellow
F2	Yell.-Gr.switch.	Colour-change yellow to green
F3	Gr.-Yell. switch	Colour-change green to yellow
F4	Yell.-Red switch	Colour-change yellow to red
ME	MB-end	Measuring range end

In this menu the same parameters are used as those described in the previous sections.

NOTICE

Unused range

If a range is not to be used, the associated switch thresholds (F1...F4) can be set to the same value.

Example

The parameter Colour is set to Auto2. Only the green, yellow and red ranges are required here. To fade out the lower ranges red and yellow, the switch thresholds "red-yellow switching" and "yellow-green switching" are set to the start of the measuring range.

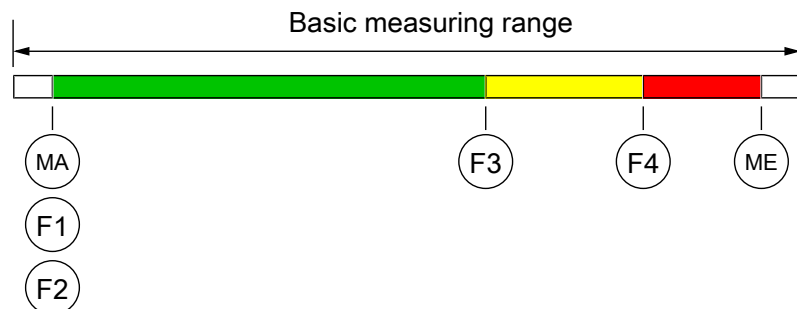

Illustration 35: Example Auto2

5.3.3.7 Menu Level System

Parameter name	Description	Value range
Language	Language change	DE, EN, FR, ES, IT,PT,HU
Software Info	Information about the software	Device type, serial number, firmware version
Config. Info	Information about the configuration	Basic measuring range, output signal, contacts
Statistics	Statistics	Operating time, switch cycles of the contacts
Password	Password	0/1...999
Load config.	Load configuration	
Save config.	Save configuration	

The user menu can be switched to German, English, French, Spanish, Italian, Portuguese or Hungarian using the parameter **Language**.

The menu items **Software Info** and **Config. Info** provide information about the device. This information helps to answer questions about the device quickly.

- The serial number and the firmware version is shown in **Software info**. If a 'designation' has been assigned, this is also issued. Please note that a 'designation' can only be entered with the PC software by remote configuration.
- The basic measuring range, the defined output signal and existing contacts are stated in the **Config. Info**.

The **Statistics** provide information about the operating time and the relay switching cycles from the time of delivery. The operating time is shown in days (d) and hours (h)

A **Password** can be used to protect the menu against unauthorised access. The password is a figure from 1 to 999. The input 0 means that no password is active.

The password needs to be set if the user presses the button in normal mode to enter the menu. If a wrong password is entered, the system automatically jumps back to normal mode again. If no password is active, the display immediately jumps to the menu.

NOTICE

Forgotten password

The user cannot restore a forgotten password. Please contact the manufacturer in this case.

The user can load a saved configuration via the menu item **Load config**. This means that a functional set of parameters can be loaded after trying out various settings.

The menu item **Save config** serves to save the existing parameters in a protected memory area. This is helpful if the settings of a functional device needs to be optimised. **Save config** and **Load config** can be used to quickly restore the initial status again.

NOTICE

Delivery condition

If the user has not yet saved a configuration, the default values (status on delivery) are loaded. In this case, any measuring range spreads or switch points are reset and the device needs to be newly configured.

5.4 Technical data

5.4.1 Input variables

Measuring variable Depends on the sensor element used.

Input signal Current signal in compliance with DIN IEC 60381-1:
 0 ... 20 mA
 4 ... 20 mA

Voltage signal in compliance with DIN IEC 60381-2:
 0 ... 10 V

5.4.2 Output parameters

Output signal 0 ... 20 mA
 4 ... 20 mA
 0 ... 10 V

Apparent ohmic resistance	0/4 ... 20 mA	0 ... 10 V
	$U_b \leq 26 \text{ V}$ $R_L \leq (U_b - 4 \text{ V}) / 0,02 \text{ A}$	$R_L > 2 \text{ k}\Omega$
	$U_b > 26 \text{ V}$ $R_L \leq 1100$	

Switching outputs 2 potential-free relay contacts
 2 potential-free semiconductor switches (MOSFET)

	Relay	MOSFET
Progr. switching function	Open contact (NO) Break contact (NC)	One-pin activator (NO) One-pin deactivator (NC)
Max. switching voltage	32 V AC/DC	3...32 V AC/DC
Max. switching current	2A	0.25 A
max. switching output	64 W / VA	8 W / VA $R_{ON} \leq 4 \Omega$

5.4.3 Measurement accuracy

Characteristic curve deviation* FS (Full Scale) refers to the basic measuring range.
 (Non-linearity and hysteresis)

Maximum	0.1 % FS
Typical	0.05 % FS

The information refers to a linear, non-spread characteristic curve at 25 °C.

Temperature coefficient	Maximum	0,1 % FS / 10 K
	Typical	0,025 % FS / 10 K

In zero-point and span with reference to the basic measuring range (not spread).

5.4.4 Auxiliary energy

Rated Voltage 24 V AC/DC

Admissible operating voltage $U_b = 20 \dots 32 \text{ V AC/DC}$

Power consumption approx. 2W (2VA)

Elektrischer Anschluss Please see the supplied electro-technology documents for information about the electrical connection.

6 TW68 Resistance thermometer

6.1 Use as intended

The compact resistance thermometer is suitable for measuring the air temperature in clean rooms and safety laboratories.

6.2 Design and mode of operation

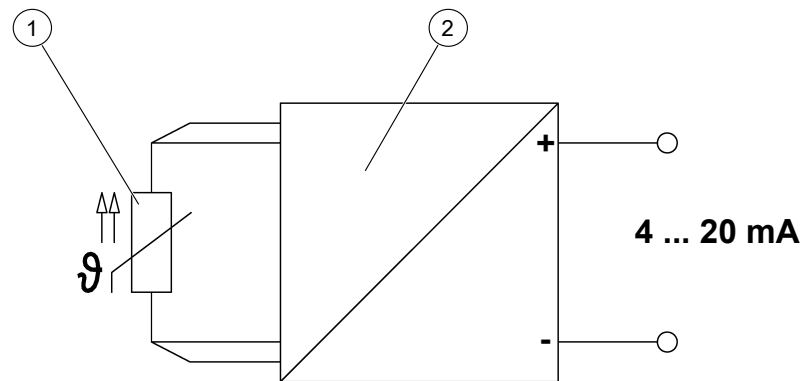

Illustration 36: Function diagram

1 Pt100 Measuring insert:	2 Measurement converter
---------------------------	-------------------------

The temperature is measured with a Pt100 measuring insert in a 4-conductor switch. The Pt100 signal is converted into an analogue output signal by an integrated measuring transducer.

6.3 Technical data

6.3.1 Input variables

Measuring variable	Temperature of gas-like media.
Measuring ranges	0 ... +50 °C Other ranges on request

6.3.2 Output parameters

Output signal	4 ... 20 mA
Apparent ohmic resistance	$(U_b - 10 \text{ V})/0,023 \text{ A}$

6.3.3 Measurement accuracy

Characteristic curve deviation*	$\pm 0,3 \text{ K}$
Long-term stability	$\leq 0.1 \text{ K/year}$
Temperature drift	0,1 %/K
Response time	1 s

6.3.4 Auxiliary energy

Rated Voltage	24 V AC/DC
Admissible operating voltage	$U_b = 20 \dots 32 \text{ V AC/DC}$

Power consumption

approx. 1W (1VA)

Electrical connection

Please see the supplied electro-technology documents for information about the electrical connection.

7 Display and control elements

7.1 Command and alarm devices

7.1.1 Pushbutton

7.1.1.1 Pushbutton with cap

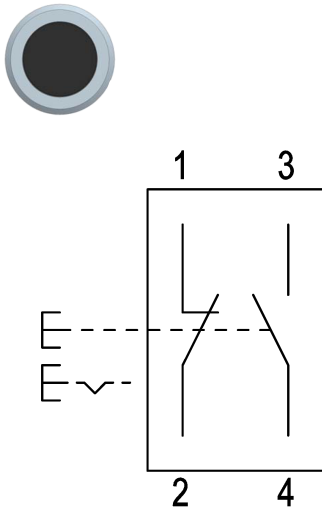

Contact element

Switching function	Impulse or break
Switch system	Jump switch element
Switching current	5A
Contacts	Ö + S
No. of contacts	1 to 4
Contact material	Gold
Max. switching voltage	250 V AC

Front frame set

Form	Round
Diameter	35 mm
Material	Stainless steel
Colour	Natural
Design	Flat

Pressure hood

Material	Aluminum
Colour	Black anodised
Design	Flat
Appearance	Opaque
Illumination	Cannot be illuminated
Protection rating	IP67

7.1.1.2 Illuminated pushbutton

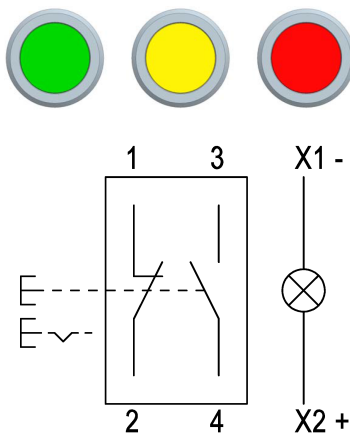

Contact element

Switching function	Impulse or break
Switch system	Jump switch element
Switching current	5A
Contacts	Ö + S
No. of contacts	1 to 4
Contact material	Gold
Max. switching voltage	250 V AC

Front frame set

Form	Round
Diameter	35 mm
Material	Stainless steel
Colour	Natural
Design	Flat

Pressure hood plastic

Material	Plastic
Colour	Green, yellow, blue, red, white
Design	Flat
Appearance	Transparent
Illumination	Can be illuminated
Protection rating	IP67

7.1.2 Signal lamp

7.1.2.1 Signal lamp type LE07

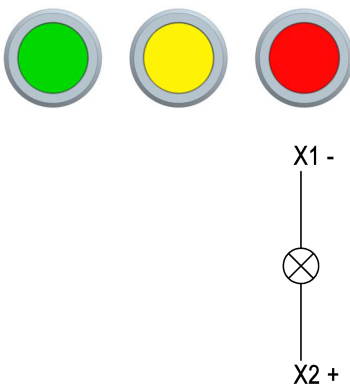

Material	Stainless steel
Diameter	35 mm
Colour	Green, yellow, blue, red, white
Design	Flat
Appearance	Transparent
Operatig voltage	24 V DC
Power consumption	ca. 60 mA
Protection rating	IP67

7.1.2.2 Signal lamp Type LE10

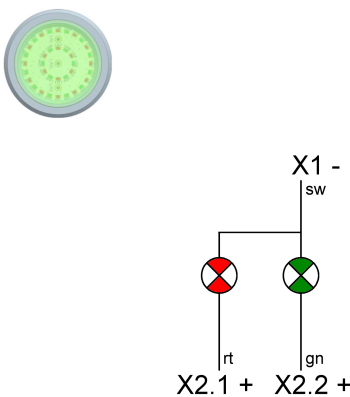

Material	Stainless steel
Diameter	47 mm
Colour	Green, red
Symbol	Concentric circles
Design	Flat
Appearance	Transparent
Operatig voltage	24 V DC
Power consumption	ca. 20 mA
Protection rating	IP67

7.1.2.3 Access signal lamp



Type LE06

Material	Stainless steel, glass
Diameter	35 mm
Sluice symbols	Green arrow Yellow triangle Red circle with slash line
Operating voltage	24 V DC
Power consumption	75 mA
Protection rating	IP67

7.1.3 Key switch

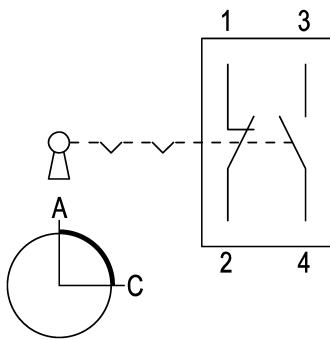
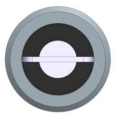

Front colour	Black
Front material	Plastic
Design	Flat
Switch angle	90 °
Protection rating	IP65
Key removal	A + C
Number of keys	2
Switching function	Rest - break
Switch levels	2
Switch system	Jump switch element
Contacts	Ö + S
No. of contacts	1 to 4
Contact material	Gold
Switching current	5A
Switching voltage	250 V AC

Front frame set

Form	Round
Diameter	35 mm
Material	Stainless steel
Colour	Natural
Design	Flat

Other locks with other switch levels and/or key removal on request.

7.1.4 Signaler (horn)



Assembly in the front plate (Type LE03)

Material	Stainless steel
Colour	Natural
Diameter	35 mm
Signaler	Piezo buzzer
Rated Voltage	24 V DC
Operating voltage	15 ... 30 V DC
Frequency	3.5 kHz ±500 Hz
Sound pressure	85 dB/10 cm
Power consumption	max. 12 mA
Protection rating	IP67

Assembly behind the front plate

Material	Plastic
Signaler	Piezo buzzer
Rated Voltage	24 V DC
Operating voltage	15 ... 30 V DC
Resonance frequency	2.9 kHz \pm 500 Hz
Sound pressure	105 dB/10 cm
Power consumption	max. 35 mA
Protection rating	IP20

7.2 Calibration pipes

Material	Stainless steel
Hood	With hole without hole
Diameter covering hood	20 mm
Hose connection	6/4 mm hose
Protection rating	IP67 (Pressure line open)

Using the calibration pipes, it is possible to calibrate the differential pressure measuring unit on site without having to remove it. To do this, both cover caps need to be unscrewed and the reference line needs to be disconnected.

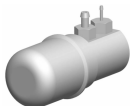
7.3 Calibration valve

Material	Stainless steel
Sealings and gaskets	Polymer, gassing resistant
Diameter	35 mm
Diameter covering hood	32 mm
Hose connection	6/4 mm hose
Protection rating	IP67

The calibration valve significantly reduces the annual calibration effort and is protected from misuse by a key switch. This key can disconnect the reference line and redirect it to the hose connection of the valve.

7.4 Room pressure filter element

Material	Stainless steel
Sealings and gaskets	Polymer (gassing resistant)
Diameter	50 mm
Cover bell	40 mm
Hepa filter	Class H14 (exchangeable)
Autoclave-capable	Housing and inner parts
Protection rating	IP67

The room pressure filter element isolates hazardous substances within the room in which the pressure is to be measured. This effectively rules out the possibility of carry-over of hazardous substances to the place where the measurements are taken.

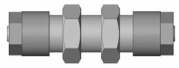

7.5 Reference pressure connection

Material	MS nickel-plated
Hose connection	6/4 mm hose 6/8 mm hose
Protection rating	IP20

The reference pressure line is usually located behind the front plate.

8 Assembly and commissioning

The dimensional drawing for the respectively supplied assembly type is stated in the supplied electro-technology documents.

Clean room panels can be supplied in the following mounting types (see Order code [▶ 62]).

Wall-mounting

Via a recess in the wall in the clean room. The minimum installation depth is 49 mm. The panel is attached with sunk-head screws.

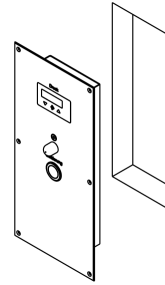

Illustration 37: Wall-mounting

Surface installation

Via surface-mounted housing on the wall of the clean room. The minimum installation depth is 52 mm. The panel is attached to the surface-mounted housing with sunk-head screws.

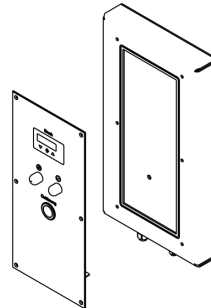

Illustration 38: Surface installation

Channel assembly

Via a cut-out in the channel. The minimum installation depth is 49 mm. The panel is attached with sunk-head screws.

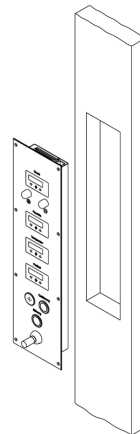

Illustration 39: Channel installation

9 Maintenance, servicing and disposal

9.1 Maintenance

We recommend the following regular inspections of the clean room panel to guarantee reliable operation and a long service life:

- Check the function in combination with downstream components.
- Calibration of the installed components
Please note the instructions in the section Components.
- Check any pressure connections lines for leaks.
- Check the electrical connections.

The exact test cycles need to be adapted to the operating and environmental conditions. In combination with other devices, the operating instructions for the other devices also need to be observed.

9.2 Transport

The clean room panel may not be exposed to mechanical shocks. It should be transported in the original packaging or a suitable transport container.

9.3 Service

All service tasks must be agreed with our sales department. All defective or faulty panels should be sent directly to our repair department. Return the device in the original packaging or a suitable transport container.

9.4 Disposal

 WARNING

Incorrect disposal may pose a risk to the environment.

Please help to protect the environment by always disposing of the work pieces and packaging materials in compliance with the valid national waste and recycling guidelines or reuse them.

10 Technical information

10.1 General

The technical data about the installed components is stated for each device type in the following sections:

- DE24 Room pressure transmitter/indicator [▶ 21]
- FT61 Humidity and temperature measuring device [▶ 36]
- EA14 Universal display [▶ 51]
- TW68 Resistance thermometer [▶ 52]

10.2 Application conditions

Ambient temperature	0 ... +50 °C
Storage temperature	-10 ... +70 °C
Enclosure protection class	According to assembly type (see below)

The panels are suitable for use in all clean room classes according to DIN EN ISO 14611-1 and EG-GMP Guide.

The resistance of the components to certain chemicals must be agreed with the sales department.

10.3 Auxiliary energy

It is connected via a terminal strip in the back of the housing cover. Please refer to the electro-technology documents for the terminals and/or wiring plan.

Please refer to the information in the wiring diagram or the technical data of the components used for information about the auxiliary energy.

NOTICE

Power supply

Please ensure that a uniform power supply is used.

10.4 Construction design

A panel comprises a front plate (V2A, vertical sanding pattern with 240 grain) and various installed components (measuring equipment, control units, signal lamps).

Assembly with sunk-head screws. There are recesses DIN 74-A4 for the sunk-head screws ISO 2009-M4 in the front plate.

The power supply is connected via terminal strips.

Wall-mounting

The clean room panel is mounted in the clean room wall with a flush-mounted aluminium cover. When installed, the stainless steel front corresponds to protection class IP67. The flush-mounted cover corresponds to protection class IP20.

Surface installation

In the case of surface-mounted devices, the front plate is mounted to a surface-mounted housing (V2A, vertical sanding pattern with a 240 grain) that meets the protection class IP67.

Channel installation

The clean room panel is mounted in the channel with a rear cover made of aluminium. When installed, the stainless steel front corresponds to protection class IP67. The cover corresponds to protection class IP20.

11 Order Codes

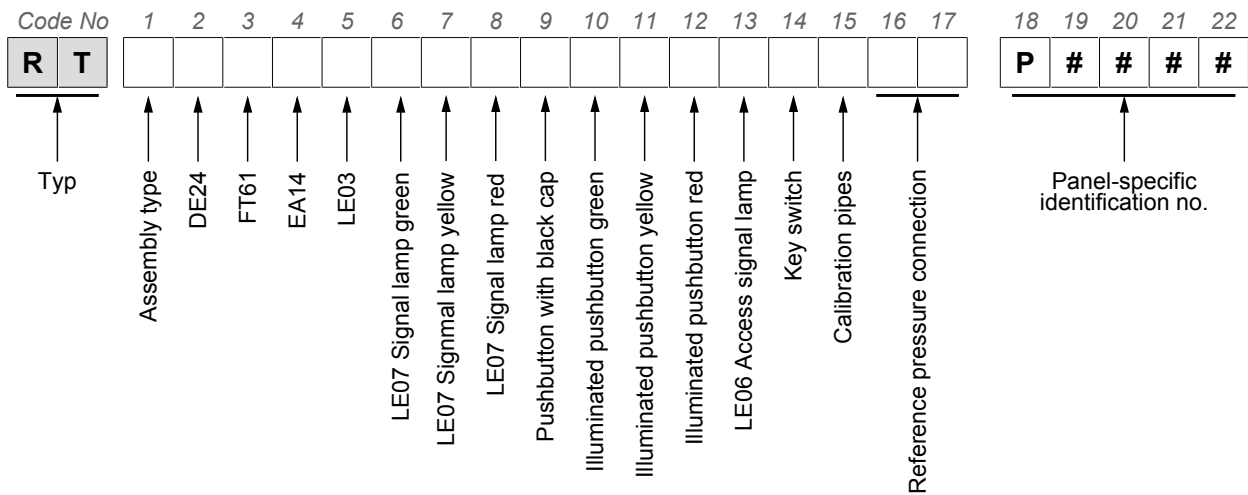

Assembly type

[1] ← **Code No**

W Wall-mounting

A Surface installation

K Channel assembly

DE24

Room pressure transmitter/indicator

[2] ← **Code No**

0 without

1 ... 9 (number of installed devices)

The device and all accessories are listed as a separate position in the order.

FT61

Humidity and temperature measuring devices

[3] ← **Code No**

0 without

1 ... 9 (number of installed devices)

The device and all accessories are listed as a separate position in the order.

EA14

Universal indicator

[4] ← **Code No**

0 without

1 ... 9 (number of installed devices)

LE03

Signaler (horn)

[5] ← **Code No**

0 without

1 Front-flush mounted signaler

2 Internally mounted signaler

LE07

Signal lamp green

[6]	←Code No
0	without
#	1 ... 9 (number of installed signal lamps)

LE07

Signal lamp yellow

[7]	←Code No
0	without
#	1 ... 9 (number of installed signal lamps)

LE07

Signal lamp red

[8]	←Code No
0	without
#	1 ... 9 (number of installed signal lamps)

Pushbutton

without

[9]	←Code No	[9]	←Code No
0	without		
1	1 x spring return	B	1 x toggle
2	2 x spring return	C	2 x toggle
3	3 x spring return	D	3 x toggle
4	4 x spring return	E	4 x toggle
5	5 x spring return	F	5 x toggle
6	6 x spring return	G	6 x toggle
7	7 x spring return	H	7 x toggle
8	8 x spring return	I	8 x toggle
9	9 x spring return	J	9 x toggle

Illuminated pushbutton green

[10]	←Code No	[10]	←Code No
0	without		
1	1 x spring return	B	1 x toggle
2	2 x spring return	C	2 x toggle
3	3 x spring return	D	3 x toggle
4	4 x spring return	E	4 x toggle
5	5 x spring return	F	5 x toggle
6	6 x spring return	G	6 x toggle
7	7 x spring return	H	7 x toggle
8	8 x spring return	I	8 x toggle
9	9 x spring return	J	9 x toggle

Illuminated pushbutton yellow

[11] ← Code No	[11] ← Code No
0	without
1	1 x spring return
2	2 x spring return
3	3 x spring return
4	4 x spring return
5	5 x spring return
6	6 x spring return
7	7 x spring return
8	8 x spring return
9	9 x spring return
B	1 x toggle
C	2 x toggle
D	3 x toggle
E	4 x toggle
F	5 x toggle
G	6 x toggle
H	7 x toggle
I	8 x toggle
J	9 x toggle

Illuminated pushbutton red

[12] ← Code No	[12] ← Code No
0	without
1	1 x spring return
2	2 x spring return
3	3 x spring return
4	4 x spring return
5	5 x spring return
6	6 x spring return
7	7 x spring return
8	8 x spring return
9	9 x spring return
B	1 x toggle
C	2 x toggle
D	3 x toggle
E	4 x toggle
F	5 x toggle
G	6 x toggle
H	7 x toggle
I	8 x toggle
J	9 x toggle

LE06**Access signal lamp**

[13] ← Code No	
0	without
#	1 ... 9 (number of installed signal lamps)

Key switch**With 2 settings**

[14] ← Code No	
0	without
#	1 ... 9 (Number of installed key switches)

Calibration pipes

[15] ← Code No	
A	without
B	1 x open
C	1 x closed
D	1 x open 1 x closed
E	2 x open
F	2 x closed
G	1 x open 2 x closed
H	2 x open 1 x closed
I	3 x open
J	3 x closed

K	1 x open	3 x closed
L	2 x open	2 x closed
M	3 x open	1 x closed
N	4 x open	
O	4 x closed	
P	1 x open	4 x closed
Q	2 x open	3 x closed
R	3 x open	2 x closed
S	4 x open	1 x closed
T	5 x open	
U	5 x closed	

Reference pressure connection

Number

[16] ← *Code No*

0 without

1 ... 9 (number of reference pressure connections)

Design

[17] ← *Code No*

00 without

10 for 6/4 hose

20 for 8/6 hose

P####

Panel-specific identification number

Not all features of a panel are covered by the order key. Therefore every panel has a panel-specific identification number with which the panel can be uniquely identified.

12 Accessories

12.1 Reference pressurized container

Pressurized container for damping atmospheric fluctuations on the reference pressure signal in pressure-controlled rooms. The amplitude of the atmospheric pressure is smoothed to a stable signal. The smoothed signal is used as a reference for following room pressure control circuits.

Order no.	09004616
Material	Polypropylene (PP)
Max. pressure	1 bar
Permissible ambient temperature	0 ... 55 °C
Diameter	200 mm
Height	1000 mm
Volume	20 l
Weight	5 kg
Ports	3/8"
Assembly	Ventilation pipe circlip in compliance with DIN EN 1506

12.1.1 Dimensioned drawing

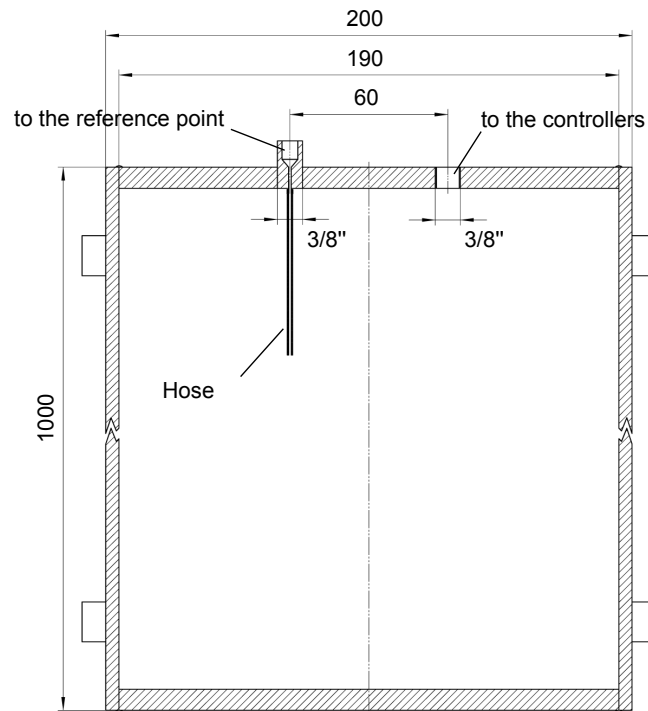

Illustration 40: Reference pressurized container

12.2 Reference pressure distributor



This distributor allows the reference pressure line to be split to 6 further main lines. The pressure connections can either be equipped with hose screw connections or plug connections. Those connections that are not required are closed with blind plugs.

Order no.	06411134
Material	Stainless steel
Diameter x length	41 x 193 mm
Distributor	1 opening 6 outlets
Hose	6/4 mm or 8/6 mm hose
Assembly	Wall mounting

12.3 Separation element

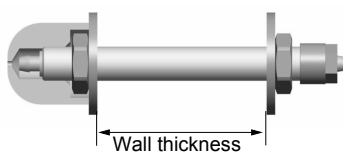

Material	MS nickel-plated
Thread	M10 x 1
Hose connection	6/4 mm hose 6/8 mm hose
Protection rating	IP20

Order no.	Wall thickness
06401349	50 mm
06401350	75 mm
06401351	100 mm
06401352	125 mm
06401353	150 mm
06401392	160 mm
06401744	250 mm

