

Operating Manual

DE44

Digital two-channel

Differential pressure switch / Transmitter

Table of Content

- 1 Safety guidelines
- 2 Intended use
- 3 Description of the product and functional description
- 4 Installation and assembly
- 5 Commissioning
- 6 Maintenance
- 7 Transport
- 8 Service
- 9 Accessories
- 10 Disposal
- 11 Technical data
- 12 Dimensional drawings
- 13 Order Codes
- 14 Declaration of Conformity

1 Safety guidelines

1.1 General Information



This operating manual contains instructions fundamental to the installation, operation and maintenance of the instrument that must be observed unconditionally. It must be read by the assembler, operator and the specialized personnel in charge of the device before it is installed and put into operation.

This operating manual is part of the product and therefore must be kept close to the device in a place that is easily accessible for the responsible personnel.

The following sections, in particular the instructions about assembly, commissioning and maintenance, contain important safety information, non-observance of which could lead to risks to people, animals, the environment and objects.

1.2 Personnel Qualification

The instrument may only be installed and commissioned by specialized personnel familiar with the installation, commissioning and operation of this product.

Specialized personnel are persons who can assess the work they have been assigned and recognize potential dangers by virtue of their specialized training, their skills and experience and their knowledge of the pertinent standards.

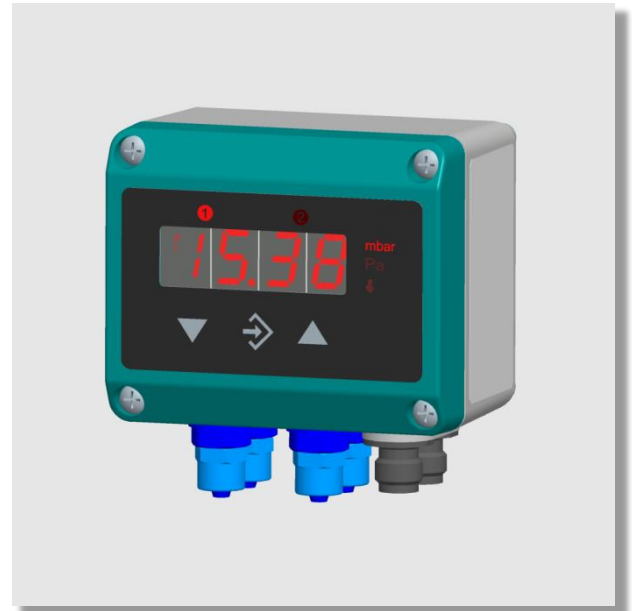

1.3 Risks due to Non-Observance of Safety Instructions

Non-observance of these safety instructions, the intended use of the device or the limit values given in the technical specifications can be hazardous or cause harm to persons, the environment or the plant itself.

Claims for damages from the manufacturer are excluded in this case.

1.4 Safety Instructions for the Operating Company and the Operator

The safety instructions on correct operation of the device shall be observed. The operating company must make them available to the installation, maintenance, inspection and operating personnel.

Dangers arising from electrical components, energy discharged by the medium, escaping medium and incorrect installation of the instrument must be eliminated. For more information, please refer to the applicable national and international regulations.

In Germany these are the DIN EN, UVV and, in industry-specific cases, the DVGW-, Ex-, GL-, etc., the VDE guidelines and the regulations of the local power utility companies.

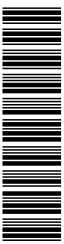
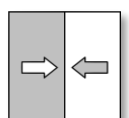

1.5 Unauthorised Modification

Modifications of or other technical alterations to the instrument by the customer are not permitted. This also applies to replacement parts. Any modifications / alterations required shall be carried out by Fischer Mess- und Regeltechnik GmbH only.

1.6 Inadmissible Modes of Operation

The operational safety of this device can only be guaranteed if it is used as intended. The device model must be suitable for the medium used in the system. The limit values given in the technical data may not be exceeded.

1.7 Safe working practices for maintenance and installation work

The safety instructions given in this operating manual, any nationally applicable regulations on accident prevention and any of the operating company's internal work, operating, and safety guidelines must be observed.

The operating company is responsible for ensuring that all required maintenance, inspection and installation work is carried out by qualified specialized personnel.

1.8 Explanation of the symbols



WARNING!

... indicates a potentially dangerous situation, non-observance of which could endanger persons, animals, the environment or objects.



INFORMATION!

... highlights important information for efficient and fault-free operation.



TIP!

... highlights recommendations that may be useful but which are not necessarily required in specific situations.

2 Intended use

Display and switching device for differential pressure of gaseous media. The instrument is to be exclusively used for the applications agreed between the manufacturer and user.

3 Description of the product and functional description

3.1 Function diagram

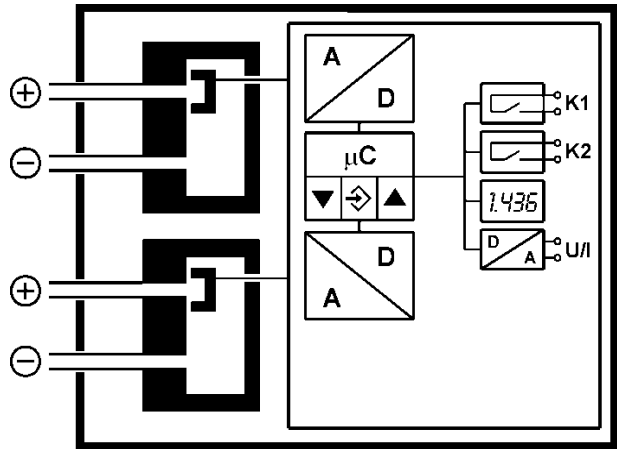

3.2 Design and mode of operation

The device is based on two piezo-resistive sensor elements that are suitable for measuring overpressure, underpressure and differential pressure. The pressures to be compared directly act on a silicon diaphragm equipped with piezo-resistive resistors. In case of equal pressure, the measuring diaphragm is in its idle state. In case of pressure difference, the force acting on the measuring membranes causes it to be moved towards the side of the lower pressure. This movement of the diaphragm induces a change of resistance, which is evaluated by the device's electronics and transformed into signals on the display, switch contacts and an output signal.

The electronics analyses both sensor signals separately. The signal from the first sensor influences the switching output 1 and the optional output signal, the output signal from the second sensor, only acts on the switching output 2.

4 Installation and assembly

The unit is designed for mounting on flat assembly plates. For screw connection to the assembly plate, the device features four assembly bores on its back, which can be used for Ø3.5 mm tapping screws.

Optionally, the device can be delivered with a wall-mounting plate (see 13, order code).

At the factory, the device is calibrated for vertical installation, but the installation position is arbitrary. For installation positions deviating from the vertical, the zero-point signal can be corrected by the integrated zero-point adjuster (see 5.3.3).

The enclosure protection type IP 65 is only guaranteed, if a suitable power supply cable is used.

If the device is intended for outdoor use, we recommend permanently protecting the membrane keypad against UV radiation and using a suitable enclosure or at least the erection of a sufficiently dimensioned canopy as a protection measure against constant rain or snow.

4.1 Process connection

- By authorized and qualified specialized personnel only.
- The pipes need to be depressurized when the instrument is being connected.
- Appropriate steps must be taken to protect the device from pressure surges.
- Check the suitability of the device for the media to be measured.
- Check that the pressure connections do not leak before commissioning.
- Maximum pressures shall be observed.
- Do not blow into the pressure connections!

The pressure connections are marked with (+) and (-) symbols on the device. For differential pressure measurements, the higher pressure is connected to the (+) side and the lower pressure to the (-) side of the device.

The pressure measuring lines must be installed on a gradient so that no air pockets e.g. for liquid measurements, water pockets or for gas measurements can be created. If the required incline is not reached, water and/or air filters need to be installed at suitable points.

The pressure sensing lines need to be kept as short as possible and installed without sharp bends to avoid interfering delay times.



If the pressure sensing lines are already pressurised at the time of commissioning, zero-point control and adjustment cannot be performed. In such cases, the device should be only connected to the mains without the pressure sensing lines.

4.2 Electronic connection

- By authorized and qualified specialized personnel only.
- The electrical connection of the device shall be performed according to relevant VDE and local electricity board regulations.
- Disconnect the system from the mains before connecting the device.
- Add a fuse adapted to the energy requirements.

Connector 1: Power supply and output signal

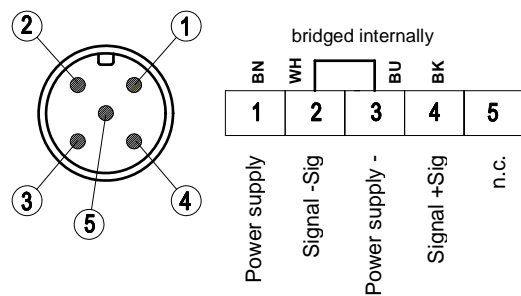

Connector 2 : Switching outputs

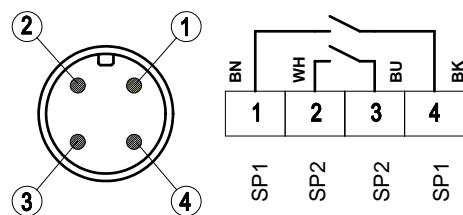

The nominal supply voltage and the permissible range can be found in the technical data.

The admissible load / resistance for the signal output is stated in the technical data.

The connection "Signal ground" (-Sig) is connected internally to the supply ground. It only serves as the ground connection for the output signal. This means that the output signal is free of interference levels on the power supply lines.

5 Commissioning

All electrical supply, operating and measuring lines, and the pressure connections must have been correctly installed before commissioning. All supply lines are arranged so that there are no mechanical forces acting on the device.

Check that the pressure connections do not leak before commissioning.

5.1 Display

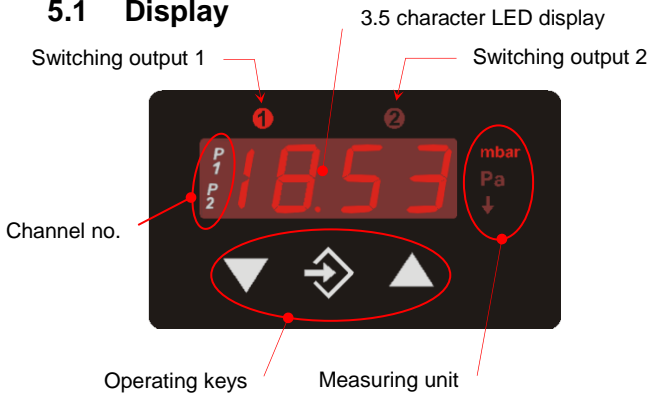

- The 3.5 digit LCD display represents the current differential pressure in normal mode.
- The selected measuring unit is illuminated on the right of the display.

 The units shown in the picture may vary from the actual model.

- Two light diodes ❶ and ❷ above the display indicate the status of the switching outputs. As soon as the switch is closed, the respective LED shines.
- On the left side, P1 and/or P2 show which channel is currently being displayed.

When the parameters are being set, the display either shows the respective menu item or the associated parameter value. The device continues to function whilst the parameters are being set; apart from two exceptions, the changes come into effect instantly.

The exceptions are firstly a change of switching times – here, the previously valid time needs to have ended and a change to the support point table (see 5.3.8 or 5.3.9). Here all output signals and switching states are frozen until the changes have been completed.

5.2 Operating keys

The operating keys have the following function:

- ▼ Page down menu
Reduce value
- ⬄ Enter key
- ▲ Page up menu
Increase value

5.3 Configuration

For commissioning there is a multitude of setting options for optimum adaptation of the device to the measuring point and task at hand. This section covers these options step by step.

Depending on the device model ¹ some menu items may not be available. For example, all characteristic curve functions are faded out in the menu if the device does not have a signal output.





It is possible to completely configure the device using a PC adapter at the PC. Here all parameters are directly visible and accessible. Also, the entire configuration can be loaded, saved and documented as a printout. For more information about this program, please refer to the program documentation (cf. Accessories).

5.3.1 General points

Connect the device to the power supply and ensure that it is not under any pressure (if necessary, disconnect any pressure lines).



Proceed as follows to set a parameter:

- Press the enter key  to switch to the menu. **ESC** will appear on the display.
- Use the arrow keys ▼▲ to select a parameter from the list.
- Press the enter key  to call up the parameter.
- Use the arrow keys ▼▲ to set the required value.
- Press the enter key  to save the value.

After setting all parameters, leave the menu as follows:²

- Use the arrow keys ▼▲ to set the **ESC** parameter. You will find these at the start and also at the end of the list of parameters.
- Press the enter key  to leave the menu.

5.3.2 Selecting the pressure unit

First select the pressure measuring unit. The unit that is currently valid is illuminated to the right of the number displays. Press the middle key  to make the setting and then search for the parameter **Ein** using the right-hand key ▲. Press  again and then change the displayed value using ▲ or ▼.

- 1 = top
- 2 = middle
- 3 = bottom

¹ with regard to the transmitter signal, voltage output, current output, etc.

² All set parameter values are only valid once you leave the menu via the **ESC** parameter.

Once the value has been selected, save it with \blacklozenge and **Ern** will appear again in the display.

Then leave the setting mode. Press \blacktriangledown until **ESC** and the \blacklozenge appear. The current measured pressure is shown again. The correct pressure unit is now illuminated to the right of this.



The display can only show up to ± 1999 . Therefore in some cases it may not be possible to select all stated pressure units.

5.3.3 Display settings

Due to the fact that the DE44 has two independent pressure measuring systems but only one display, you can use the **dSP** parameter to select whether you want to have only the first channel (**dSP** = 0.0), only the second channel (**dSP** = 0.1) or both channels alternately (**dSP** = 0.2 to 99.9) displayed. From 0.2 s upwards, the value simply determines the retention period (0.2 s to 99.9 s per channel). So that it is clear which value is currently being displayed, the symbols P1 for the 1st channel and P2 for the 2nd channel are shown accordingly on the left edge of the display.



It is advisable for the other settings to initially select a slow switching time (e.g. 3 s). This saves you the effort of having to switch between P1 and P2 manually.

5.3.4 Zero point control and adjustment

Ensure that the device is not under any pressure (if necessary, disconnect any pressure lines).

If the device does precisely indicate zero at this point of time, parameter **oFI** enables you to adjust the measuring value exactly to zero. To do so, you have to set the measuring value indicated below **oFI** to zero.

Due to the fact that the DE44 has two independent pressure measuring systems, there is also an offset correction parameter **oF2** for the second measuring channel. The function and effect is identical to **oFI**.

After zero-point adjustment, the pressure sensing lines can be reconnected.

5.3.5 Damping and zero-point stabilising

If there are unsteady pressure readings at this point of time or during operation, you can use parameters **dRN** and **nP** to stabilise the reading (and the output signal).

The parameter **dRN** functions like a capillary throttle. However, it only acts on the display, output signal and switch points but not on the measuring cell itself. This parameter can be used to set the reaction time to the pressure jumps. The value range is 0.0 s to 100.0 s.



But with maximum attenuation, it will take more than 2 minutes for the reading to also reach zero after a pressure jump from nominal pressure (100 %) to zero!

In many cases, unsteady readings are not a problem during normal operating mode, but this is not true for the idle state, i.e. if zero (differential) pressure is expected.

In such situations, parameter **nP** can be applied. Its value defines a measuring value range around zero. Within this range, the measuring value is set to zero.

Example:

A value of 0.08 mbar³ is entered for **nP**. In this case all pressures within the range of -0.08 mbar to +0.08 mbar are set to zero. The reading will only not indicate zero anymore if the pressure exceeds these limits. However, the pressure value and display do not correspond to one hundred percent. The measuring pressure and reading match again when the double value, in this case 0.16 mbar, is reached again.

5.3.6 Setting the output signal

The transmitter output signal primarily depends on the sensed pressure. However, you have the option of adjusting the output signal to a large extent to suit your requirements.



However, the basic measuring range (indicated on the type label) and the type of output signal (voltage / current) are not variable.

Parameters **NR** (start of measuring range) and **NE** (end of measuring range) define the two pressures between which the output signal can generally change. Both values are adjustable across the entire basic measuring range. The set values always refer to pressure (in the relevant measuring unit) and are converted when the measuring unit is changed.

The assigned signal values for **NR** and **NE** are invariable (type label, e.g. 0...10 V or 4...20 mA).



If the parameter **NR** and/or **NE** is changed, a support point table that is active at this time will be deleted (cf. 5.3.8 or 5.3.9).

If **NR** is smaller than **NE** this is referred to a rising characteristic curve. The output signal grows as the pressure increases.

If **ME** is smaller than **MA**, this is a decreasing characteristic curve and the output signal decreases with the falling pressure.

³ 0.08 mbar \approx 8 Pa

The difference between values NR and NE must at least be 25 % of the basic measuring range. The software does not allow any larger spreads. If the range information is stated wrongly, you cannot leave the menu.

 **Example:**
The following must apply for a basic measuring range of 400 Pa: $NR - NE \geq 100$ Pa.

5.3.7 Output signal limits (Namur)

Regardless of the pressure, the three parameters $oG1$, $oG2$ and oEr define the limit values for output currents or voltages that may not be undercut or exceeded.

These limit values have priority over the range defined by the NR and NE . They primarily serve to prevent error messages in downstream systems caused by brief overstepping of measuring ranges.

The parameter $oG1$ defines the limit value for the minimum output signal. The output signal may not undercut this value. Usually, this parameter is only recommended for devices with an output signal of 4..20 mA because in these devices, a value below 3.8 mA is often assessed as an error signal.

The parameter $oG2$ defines the limit value for the maximum output signal. The output signal may not exceed this value. This parameter can be used for all outputs (voltage and current) to limit the maximum value of e.g. 10.2 V.

The parameter oEr defines the value for the error signal. The value defined via the oEr is issued as an output signal, if the device detects an internal error and can no longer work correctly. However, the device is not able to recognise all possible errors and defects.

If you set $oG1 = oG2 = 0$, the output signal will no longer be checked for limits.

 **Tipp** If you set $oG1$ to the maximum value (11 V or 21 mA), you can use $oG2$ to adjust the output signal independent of the pressure from zero to the maximum value. You do not need to leave the menu item, the output is directly changed. You operate the device then as a transducer and can simply check the further signal processing.

5.3.8 Characteristic curve function F

In some applications, measuring pressure is an indirect unit for the actual measuring variable. Flow measurements via a panel or determining the filling level by means of hydrostatic pressure measurements are two typical examples of this. In these cases, you might want to change the output signal of the transmitter to a non-linear characteristic curve so that the following analysis receives a signal that is linear-proportional to the actual measur-

ing variable (e.g. volume in m^3 or volume flow cm^3/s etc.)

The parameter F allows you to select between the following variants:

F	
0	linear characteristic curve (standard)
1	square rooted characteristic curve
2	flat cylindrical tank
3...30	Support point table with 3 to 30 pairs of values

Whenever you change the value from F , the program creates a new table. All previous values in the table are rejected and replaced with new linear entries.

The tables of type $F = 0$ to $F = 2$ are not visible. Internal values are used here to calculate the table. These values are invariable.

For $F = 3...30$, you can only influence the 1..28 interim values. You only have access to the start and end values via the NR and NE parameters (cf. 5.3.6).

 When the parameters NR and NE are changed the table is deleted and $F = 0$ is set.

At the start of the measuring range (NR) 0% of the output signal (e.g. 0 mA) is issued.

At the end of the measuring range (NE) 100% of the output signal (e.g. 20 mA) is issued.

5.3.9 Menu jump Lin

If the value of F is greater than or equal to 3, there is a submenu Lin . Here you can access all table values apart from the table start (NR) and end (NE).

This submenu has its own entry and exit point that is shown with End . The table is only saved if you return to the main menu at this point, i.e. if you change to the parameter Lin again via the key \blacklozenge .

If the table is not structured correctly, an error message Err will appear here and you cannot quit the submenu.

The table comprises 3...30 pairs of values. In the case of a device with a power output, the first pair of values is $\{o1|p01\}$ ⁴. The first value $o1$ defines the output signal. The second value $p01$ determines the pressure at which the output signal is issued.

Followed by the pairs of values $\{o2|p02\} \dots \{o30|p30\}$.

Entering or changing values in the table via the membrane keypad is tiresome and prone to errors. This is only intended as an emergency solution in case access to the PC adapter is not possible.

⁴ At a voltage output $\{u01|p01\} \dots \{u30|p30\}$.

The table is correct if the following applies for all signal values: The value is larger than the previous value. Either larger (rising characteristic curve) or smaller (falling characteristic curve) apply to the pressure values accordingly. No transition from rising to falling characteristic curves or vice versa is allowed.

5.3.10 Switch points

The two switch outputs ① ② are configured by four parameters respectively.

The function of the switching output ① is determined by the parameters $r1A$, $r1E$, $r1d$ and $r1F$.

The function of the switching output ② is determined by the parameters $r2A$, $r2E$, $r2d$ and $r2F$.

$r1A$ defines the switch-off point, $r1E$ defines the switch-on point of switch output 1. The values are set in the valid measuring unit (shown on the right).

Together, the two parameters $r1A$ and $r1E$ determine the switch function of switch output 1:

If $r1A$ is smaller than $r1E$, the output switches on, if the measured value exceeds $r1E$. It is only switched off again if the measured value $r1A$ is undercut (hysteresis function).

If $r1A = r1E$, the output switches on if the measured value exceeds $r1E$ and off if the measured value undercuts $r1A$.

If $r1A$ is larger than $r1E$, the output switches on, if $r1E < \text{Measured value} < r1A$ applies (window function).

Both parameters can be set independently over the entire range.

If the measuring unit is switched over, the switching points are converted accordingly. Rounding errors may cause deviations in the last position.

$r1d$ allows the reaction of the switch output 1 to be delayed by between 0.0 and 100.0 s. This value applies equally for switching on and off.

$r1F$ reverse the function of the switch output. If the value = 1, the switch output works as an NO contact, if the value = 2, the switch out works as a NC contact.

5.3.11 Password

The last menu item **-P-** is used to enter a password. A value between 001 and 999 can be selected for the password. The value 000 cancels the password function.

If a password has been issued, the text **PAS** appears after **ESC** and **↩**, and you need to enter the correct value using **↩** and **▲▼**. You will only arrive at all other menu items after doing this. In the event of an error, the display will jump back to the start of the menu **ESC**.



If the password is forgotten, it can only be reset by the manufacturer or overwritten via the PC adapter.

5.3.12 Display options

The parameter $d0$ enables the reading to settle if the measuring value fluctuates heavily. This filter function is similar to the dRN function, but only impacts on the reading not on the output signal. At $d0 = -1$ only the switchpoint LEDs are controlled. At $d0 = -2$ these are switched off.

5.3.13 Reset to default

The function $rE5$ allows all settings to be reset to the default settings. The default values can only be defined via a PC interface.

5.3.14 Free unit

If the device is designed for a "free" third unit (membrane symbol: **▼**), the display can be scaled infinitely using the parameters nAF , nEF and dPF .

The measuring range defined by the parameters nA and nE is converted to nAF and nEF . This also takes into account the table function (F). The value of dPF determines the position of a decimal point.

5.4 Parameter overview

After switching on the device, it will briefly indicate the software version number and then enters the normal operating mode. By using the middle **↩** key on the membrane keypad you can access the parameter menu. The reading now shows the text **ESC**. By using the right **▶** key, you can choose the parameters from the following list one by one:



Note:

Depending on the device model, individual parameters may not be available if the device does not have this feature.

PAS

Enter password

(only appears if the password is active), value range 000...999
000 = deactivated

dRN

Attenuation

(Jump response time T90),
value range 0.0..100.0s

d0

Display attenuation

Value range -2...0...100.
-2 = Display off, LED Switch point off
-1 = Display off, LED Switch point on
0 = Display on, LED Switch point on
1...100 Display attenuation

r1A

Switch-off point

From switching output ①

rIE	Switch-on point From switching output ①	NEF	Free unit End of measuring range (display)
rId	Switching delay from switch output • ① Value range 0.0 to 100.0s. This value applies equally for switching on and off.	oFI	Offset correction measuring input 1 Value range $-\frac{1}{3}$ FS...0... $+\frac{1}{3}$ FS
rIF	Switching function From switching output ① Values range 1,2 1 = Switching output as NO contact, 2 = Switching output as NC contact	F	Characteristic curve function Value range 0...30 0 = linear, 1 = square rooted, 2 = flat cylindrical tank 3..30 = Table
r2A	Switch-off point From switching output ②	Lin	Menu jump Submenu table processing If F < 3 this menu item is faded out.
r2E	Switch-on point From switching output ②	oG1	Limit value Minimum output signal
r2d	Switching delay from switch output • , ② Value range 0.0 to 100.0s. This value applies equally for switching on and off.	oG2	Limit value Maximum output signal
r2F	Switching function From switching output ② Values range 1,2 1 = Switching output as NO contact, 2 = Switching output as NC contact	oEr	Error signal (Output signal in error case)
on	Measuring range unit Value range 1,2,3 The selection is illuminated on the right of the reading. Not all basic measuring ranges allow free switchover. The respective unit size can only be selected if the basic measuring range of the device can be shown sensibly.	rES	Reset all parameters to standard values (specification of the standard values per PC)
oA	Start of measuring range The measuring value is set in that the output signal is minimal. (e.g.: 0V, 0mA or 4mA).	-P-	Password setting Value range 000 to 999 Value 000 does not hold password protection.
oE	End of measuring range The measuring value is set in that the output signal is maximum. (e.g.: 10V, or 20mA).		
oP	Zero-point stabilising Value range 0 to $\frac{1}{3}$ of the basic measuring range. The value acts symmetrically around real zero.		
dPF	Free unit Decimal point position		
oAF	Free unit Start of measuring range (display)		

6 Maintenance

The device is maintenance-free.

We recommend regular inspections to guarantee reliable operation and a long life cycle, such as:

- Checking the reading.
- Checking the switching function in combination with downstream components.
- Checking the leak-tightness of the pressure connection lines.
- Checking the electrical connection (cable clamp connections).

The exact test cycles shall be adapted to the operating and ambient conditions. The operating manuals of any other connected device components shall also be observed.

7 Transport

The device must not be exposed to mechanical shocks. It shall be transported only in packaging specifically intended for transport.

8 Service

All damaged or faulty devices shall be directly sent to our repair department. Please coordinate the return of any device with our sales department.



Process media residues in and on dismantled instruments can be a hazard to people, animals and the environment. Take adequate preventive measures. If required the devices shall be thoroughly cleaned.

9 Accessories

- Set of cables with M12 connectors (please enquire)
- PC adapter with type EU03.F300 software

10 Disposal

For the sake of the environment ...



Please help to protect our environment and dispose of or recycle used devices as required by the applicable regulations.

11 Technical data

		Positive ranges (0 ...)								+/- ranges									
Basic measuring range		mbar	4	6	10	16	25	40	60	100	±2.5	±4	±6	±10	±16	±25	±40	±60	±100
		Pa	400	600	1000	1600					±250								
		kPa			1	1.6	2.5	4	6	10				±1	±1.6	±2.5	±4	±6	
Max. stat. operating pressure		mbar	50		100		250		500		50		100		250		500		
Bursting pressure		mbar	150		300		750		1500		150		300		750		1500		
Characteristic curve deviation °)	max.	%FS	1.0								1.0								
	typ.	%FS	0.5								0.5								
TC span °°)	max.	%FS/10K	1.0	0.3				1.0		0.5	0.3								
	typ.	%FS/10K	0.3				0.3												
TC zero point °°)	max.	%FS/10K	1.0	0.4				1.0		0.5	0.4								
	typ.	%FS/10K	0.2				0.2												

°: Characteristic curve deviation (non-linearity and hysteresis) at 25°C, basic measuring range (linear characteristic curve, not spread)
 °°) : in relation to basic measuring range (not spread), compensation range 0 ... 60°C

	General points	
Admissible ambient temperature	-10 ... 70°C	
Admissible media temperature	-10 ... 70°C	
Admissible storage temperature	-20 ... 70°C	
Enclosure protection class	IP 65 acc. to DIN EN 60529	
	Electrical data	
Nominal voltage	24 V DC / AC	
Admissible operating voltage U_b	12 ... 32 V DC / AC	
Electrical connection type	Three-wire	
Output signal	Current output	Voltage output
	0 ... 20 mA, 4 ... 20 mA	0 ... 10 V DC
Admissible apparent ohmic resistance	$R_L \leq (U_b - 4 V) / 0.02 A$ ($U_b \leq 26V$) $R_L \leq 1100\Omega$ ($U_b > 26V$)	$R_L \geq 2 K\Omega$ ($U_b \geq 15V$) $R_L \geq 10 K\Omega$ ($U_b = 12 ... 15V$)
Characteristic curve	can be programmed	
Power consumption	approx. 2 W / VA	
Display	3.5 character LED	
	Switch contacts	
Relay contacts	2 potential-free relay contacts programmed as NO contact or NC contact $U_{max} = 32V AC/DC$, $I_{max} = 2 A$, $P_{max} = 64 W/VA$	
Semiconductor switch	2 potential-free semiconductor switches (MOSFET), SPST-NO/NC progr. $U = 3 ... 32V AC/DC$, $I_{max} = 0.25A$, $P_{max} = 8 W/VA$, $R_{ON} \leq 4 \Omega$	
	Connections	
Process connection	Hose screw connections made of Al, 6/4 mm or 8/6 mm	
electr. connection	2 x round plug connector M12 Connector 1 for supply and analogue output signal (5-pole, male) Connector 2 for switch contacts (4-pin, male)	
	Materials	
Casing	Polyamide PA 6.6	
Media-contacting material	Silicon, PVC, aluminium, brass	
	Assembly	
	Bore-holes on the reverse side for attachment of the assembly panels. Wall mounting by means of assembly plate. If the device is intended for outdoor use, we recommend permanently protecting the membrane keypad against UV radiation and using a suitable enclosure or at least the erection of a sufficiently dimensioned canopy as a protection measure against constant rain or snow.	

11.1 Programming

Programming is carried out via the membrane keypad and menu navigation; can be locked with a password

	Settings
Attenuation	0.0 ... 100.0 s (jump response time 10 / 90 %) for signal output; separately also for display
Selection of the displayed measuring value	0.0 = only differential pressure 1 (dP1) 0.1 = only differential pressure 1 (dP1) 0.2 ... 25.5 = switchover time in seconds, dP1 and dP2 alternately ⁽⁰⁾
Switching output 1 / 2	Switch-off point, switch-on point, response time (0...100s), function (NC / NO contact) ⁽⁴⁾
Measuring range unit	mbar / Pa / "free unit", starting value, end value and decimal point for "free unit"
Zero-point stabilising	0 ... 1/3 of the basic measuring range ⁽¹⁾
Output signal	User-definable within the basic measuring range ^{(2) (4)}
Zero point correction	$\pm 1/3$ of the basic measuring range ⁽³⁾
Implementation of characteristic curve	linear, square rooted, flat cyl. tank, table with 3...30 support points
Password	001 ... 999 (000 = no password protection)

Comments:

- (0): For values from 0.2, the display switches between dP1 and dP2 rhythmically.
- (1): Measuring values (around zero) are set to zero. (e.g. to suppress seepage).
- (2): Maximum effective spread 4:1. Only the output signal is influenced. This in turn enables a decreasing characteristic curve, if the start of the measuring range > end of the measuring range.
- (3): Zero point correction for compensation of various installation positions.
- (4) Differential pressure 1 (dP1) controls switching output 1 and the output signal
Differential pressure 2 (dP2) controls switching output 2

12 Dimensional drawing (all dimensions in mm unless otherwise specified)

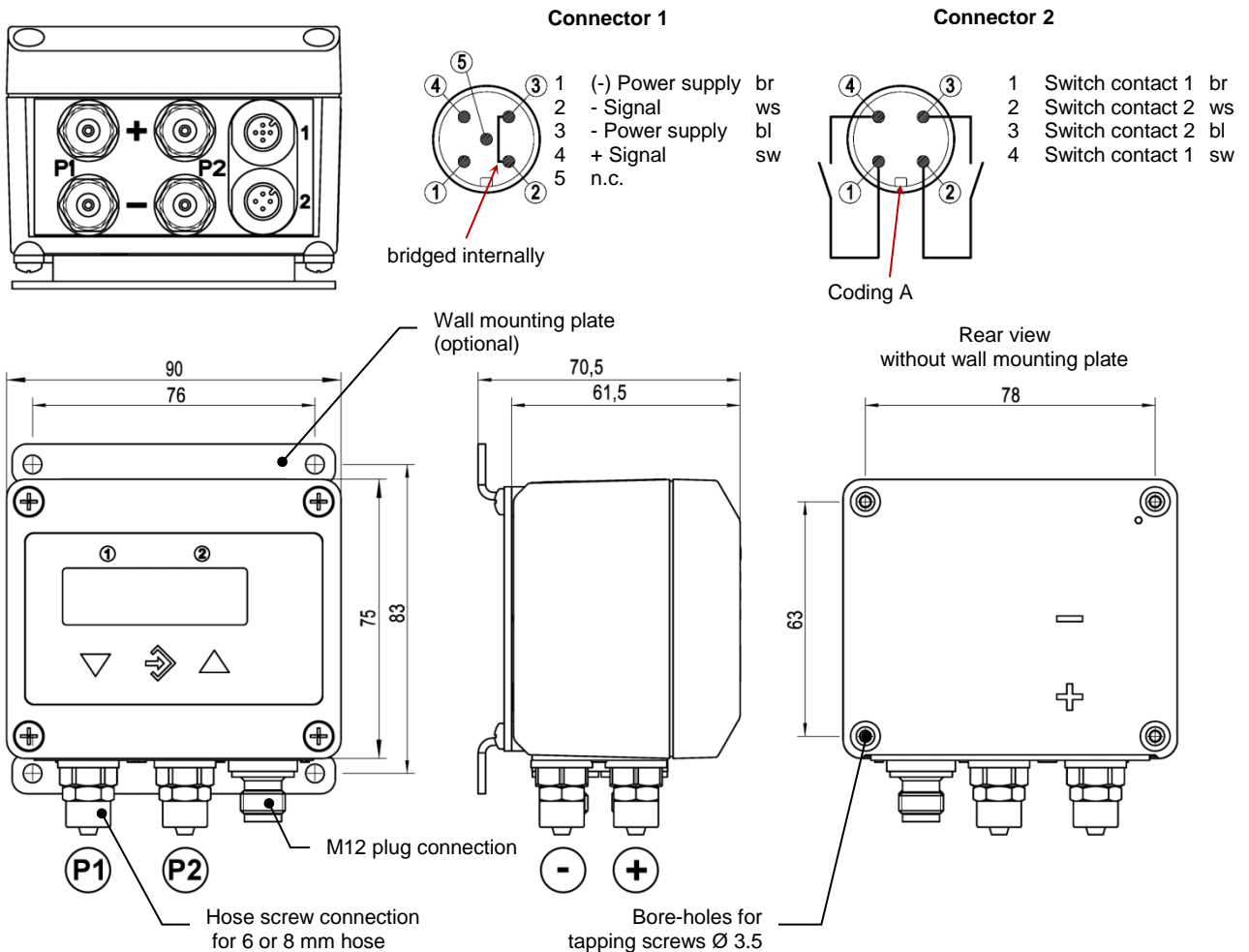

13 Order Codes

**Digital 2-channel differential pressure switch/transmitter
with 3 1/2-digit LED display**

DE44

						K			M	
--	--	--	--	--	--	---	--	--	---	--

Channel 1 - measuring range



0 ... 4	mbar.....>	5	2
0 ... 6	mbar.....>	5	3
0 ... 10	mbar.....>	5	4
0 ... 16	mbar.....>	5	5
0 ... 25	mbar.....>	5	6
0 ... 40	mbar.....>	5	7
0 ... 60	mbar.....>	5	8
0 ... 100	mbar.....>	5	9
-2.5 ... +2.5	mbar.....>	A	6
-4 ... +4	mbar.....>	A	7
-6 ... +6	mbar.....>	A	8
-10 ... +10	mbar.....>	A	9
-16 ... +16	mbar.....>	B	1
-25 ... +25	mbar.....>	B	2
-40 ... +40	mbar.....>	C	5
-60 ... +60	mbar.....>	B	3
-100 ... +100	mbar.....>	B	4
0 ... 400	Pa.....>	D	7
0 ... 600	Pa.....>	D	8
0 ... 1000	Pa.....>	D	9
0 ... 1600	Pa.....>	E	1
-250 ... +250	Pa.....>	L	6
0 ... 1	kPa.....>	N	1
0 ... 1.6	kPa.....>	N	2
0 ... 2.5	kPa.....>	N	3
0 ... 4	kPa.....>	N	4
0 ... 6	kPa.....>	N	5
0 ... 10	kPa.....>	E	5
-1 ... +1	kPa.....>	L	8
-1.6 ... +1.6	kPa.....>	L	9
-2.5 ... +2.5	kPa.....>	M	6
-4 ... +4	kPa.....>	M	7
-6 ... +6	kPa.....>	M	8

**Digital 2-channel differential pressure switch/transmitter
with 3 1/2-digit LED display**

DE44

								K			M	
--	--	--	--	--	--	--	--	---	--	--	---	--

Channel 2 - measuring range

0 ... 4 mbar	>	5	2
0 ... 6 mbar	>	5	3
0 ... 10 mbar	>	5	4
0 ... 16 mbar	>	5	5
0 ... 25 mbar	>	5	6
0 ... 40 mbar	>	5	7
0 ... 60 mbar	>	5	8
0 ... 100 mbar	>	5	9
-2.5 ... +2.5 mbar	>	A	6
-4 ... +4 mbar	>	A	7
-6 ... +6 mbar	>	A	8
-10 ... +10 mbar	>	A	9
-16 ... +16 mbar	>	B	1
-25 ... +25 mbar	>	B	2
-40 ... +40 mbar	>	C	5
-60 ... +60 mbar	>	B	3
-100 ... +100 mbar	>	B	4
0 ... 400 Pa	>	D	7
0 ... 600 Pa	>	D	8
0 ... 1000 Pa	>	D	9
0 ... 1600 Pa	>	E	1
-250 ... +250 Pa	>	L	6
0 ... 1 kPa	>	N	1
0 ... 1.6 kPa	>	N	2
0 ... 2.5 kPa	>	N	3
0 ... 4 kPa	>	N	4
0 ... 6 kPa	>	N	5
0 ... 10 kPa	>	E	5
-1 ... +1 kPa	>	L	8
-1.6 ... +1.6 kPa	>	L	9
-2.5 ... +2.5 kPa	>	M	6
-4 ... +4 kPa	>	M	7
-6 ... +6 kPa	>	M	8

**Digital 2-channel differential pressure switch/transmitter
with 3 1/2-digit LED display**



Pressure connection

- Aluminium screw connection for 6 / 4 mm hose> 4 0
- Aluminium screw connection for 8 / 6 mm hose> 4 1

Electrical output signal (only channel 1)

- without analogue electrical output signal> 0
- 0 – 20 mA 3-wire (STANDARD)> A
- 0 – 10 V DC 3-wire (STANDARD)> C
- 4 – 20 mA 3-wire (STANDARD)> P

Operating voltage

- 24 V DC/AC (12 - 32 V DC/AC)> K

Measuring unit

- Standard pressure units> 0

Measured value display / contact elements

- 3 1/2-digit-LED – 2 relay contacts> 3
- 3 1/2-digit-LED – 2 semiconductor switches> 6

Electrical connection

- M12 plug connection> M

Assembly option

- Standard (attachment boreholes on rear side)> 0
- Wall mounting> W

13.1 Accessories

Order Code	Designation	No. of Poles	Usage	Length
06401993	Connection cable with M12 connector	4-pole	for switching outputs	2 m
06401994	Connection cable with M12 connector	4-pole	for switching outputs	5 m
06401995	Connection cable with M12 connector	5-pole	for supply / signal	2 m
06401996	Connection cable with M12 connector	5-pole	for supply / signal	5 m
EU03.F300	Adapter for parameterization via PC software			

14 Declaration of Conformity



EU Declaration of Conformity

(Translation)

For the product described as follows

Product designation **Digital 2-channel differential pressure switch/
-transmitter with 3½-digit LED display**

Type designation **DE44**

it is hereby declared that it corresponds with the basic requirements specified in the following designated directives:

2014/30/EU *EMC Directive*

2011/65/EU *RoHS Directive*

The products were tested in compliance with the following standards.

Electromagnetic compatibility (EMC)

EN 61326-1:2013 *Electrical equipment for measurement, control and laboratory use - EMC requirements - Part 1: General requirements*

EN 61326-2-3:2013 *Electrical equipment for measurement, control and laboratory use - EMC requirements - Part 2-3: Particular requirements - Test configuration, operational conditions and performance criteria for transducers with integrated or remote signal conditioning*

RoHS

EN 50581:2012 *Technical documentation for the assessment of electrical and electronic products with respect to the restriction of hazardous substances*

Also they were subjected to the conformity assessment procedure „**Internal production control**“.

Sole responsibility for the issue of this declaration of conformity in relation to fulfilment of the fundamental requirements and the production of the technical documents is with the manufacturer.

Manufacturer **FISCHER Mess- und Regeltechnik GmbH**

Bielefelder Str. 37a
32107 Bad Salzufflen, Germany
Tel. +49 5222 974 0

Documentation representative Mr. T. Malischewski
B. Sc.
Development department

The devices bear the following marking:



**Bad Salzufflen,
14 Nov 2018**

ppa. F. Hempelmann
Authorized signatory



