



Ex II1/2G Ex ia IIC T4 Ga/Gb
Ex II 2D Ex ia IIIC T80°C Db



RoHS II
COMPLIANT



Operating manual

DE49 ## 0

Digital differential pressure transmitter

for explosive areas
Dust explosion protection zone 21 and 22, dry dusts
Gas explosion protection zone 1 and 2, gases and vapors

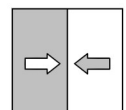

Masthead

Manufacturer: FISCHER Mess- und Regeltechnik GmbH

Bielefelderstr. 37a
D-32107 Bad Salzuflen

Telephone: +49 5222 974 0
Telefax: +49 5222 7170

eMail: info@fischermesstechnik.de
web: www.fischermesstechnik.de

Technical editorial team: Documentation representative: T. Malischewski
Technical editor: R. Kleemann

All rights, also those to the translation, reserved. No part of this document may be reproduced or processed, duplicated or distributed using electronic systems or any other form (print, photocopy, microfilm or another process) without the written consent of the company FISCHER Mess- und Regeltechnik GmbH, Bad Salzuflen.

Reproduction for internal use is expressly allowed.

Brand names and procedures are used for information purposes only and do not take the respective patent situation into account. Great care was taken when compiling the texts and illustrations; Nevertheless, errors cannot be ruled out. The company FISCHER Mess- und Regeltechnik GmbH will not accept any legal responsibility or liability for this.

Subject to technical amendments.



© FISCHER Mess- und Regeltechnik 2017

Version history

Rev.A	01/10	WORD	First issued
Rev.B	06/11	WORD	Type testing 1st supplement
Rev. ST4-A	02/17	SCHEMA ST4	Version 1 (new EU guidelines 04/2016)
Rev. ST4-B	07/17	SCHEMA ST4	Version 2 (Ground connection)
Rev. ST4-C	01/18	SCHEMA ST4	Version 3 (Parameter Medium)
Rev. ST4-D	07/18	SCHEMA ST4	Version 4 (Order codes)

Table of contents

1	Safety guidelines	4
1.1	General	4
1.2	Personnel Qualification	4
1.3	Risks due to Non-Observance of Safety Instructions	4
1.4	Safety Instructions for the Operating Company and the Operator	4
1.5	Unauthorised Modification	5
1.6	Inadmissible Modes of Operation	5
1.7	Safe working practices for maintenance and installation work	5
1.8	Pictogram explanation	5
2	Product and functional description	7
2.1	Lieferumfang	7
2.2	Intended use	7
2.3	Equipment versions	7
2.4	Function diagram	8
2.5	Design and mode of operation	8
3	Assembly	9
3.1	General	9
3.2	Process connection	9
3.3	Electrical connections	10
4	Commissioning	12
4.1	Generalities	12
4.2	Control elements	12
4.3	Parameters	12
5	Servicing	19
5.1	Maintenance	19
5.2	Transport	19
5.3	Service	19
5.4	Disposal	19
6	Technical data	20
6.1	General	20
6.2	Input variables	20
6.3	Output parameters	20
6.4	Measurement accuracy	20
6.5	Display and control elements	21
6.6	Auxiliary energy	22
6.7	Application conditions	22
6.8	Construction design	22
7	Order Codes	25
7.1	Accessories	27
8	Attachments	28

1 Safety guidelines

1.1 General

This operating manual is an integral part of the product and therefore needs to be kept close to the instrument in a place that is accessible at all times to the responsible personnel.

The following sections, in particular instructions about the assembly, commissioning and maintenance, contain important information, non-observance of which could pose a threat to humans, animals, the environment and property.

The instrument described in these operating instructions is designed and manufactured in line with the state of the art and good engineering practice.

1.2 Personnel Qualification

The instrument may only be installed and commissioned by specialized personnel familiar with the installation, commissioning and operation of this product.

Specialized personnel are persons who can assess the work they have been assigned and recognize potential dangers by virtue of their specialized training, their skills and experience and their knowledge of the pertinent standards.

For explosion-proof models the specialized personnel must have received special training or instruction or be authorized to work with explosion-proof instruments in explosion hazard areas.

1.3 Risks due to Non-Observance of Safety Instructions

Non-observance of these safety instructions, the intended use of the device or the limit values given in the technical specifications can be hazardous or cause harm to persons, the environment or the plant itself.

The supplier of the equipment will not be liable for damage claims if this should happen.

1.4 Safety Instructions for the Operating Company and the Operator

The safety instructions governing correct operation of the instrument must be observed. The operating company must make them available to the installation, maintenance, inspection and operating personnel.

Dangers arising from electrical components, energy discharged by the medium, escaping medium and incorrect installation of the device must be eliminated. See the information in the applicable national and international regulations.

Please observe the information about certification and approvals in the Technical Data section.

The instrument must be decommissioned and secured against inadvertent re-operation if a situation arises in which it must be assumed that safe operation is no longer possible. Reasons for this assumption could be:

- evident damage to the instrument
- failure of the electrical circuits
- longer storage outside the approved temperature range.
- considerable strain due to transport

Repairs may be carried out by the manufacturer only.

A professional single conformity inspection as per DIN EN 61010, section 1, must be carried out before the instrument can be re-commissioned. This inspection must be performed at the manufacturer's location. Correct transport and storage of the instrument are required.

1.5 Unauthorised Modification

Modifications of or other technical alterations to the instrument by the customer are not permitted. This also applies to replacement parts. Only the manufacturer is authorised to make any modifications or changes.

1.6 Inadmissible Modes of Operation

The operational safety of this instrument can only be guaranteed if it is used as intended. The instrument model must be suitable for the medium used in the system. The limit values given in the technical data may not be exceeded.

The manufacturer is not liable for damage resulting from improper or incorrect use.

1.7 Safe working practices for maintenance and installation work

The safety instructions given in this operating manual, any nationally applicable regulations on accident prevention and any of the operating company's internal work, operating and safety guidelines must be observed.

The operating company is responsible for ensuring that all required maintenance, inspection and installation work is carried out by qualified specialized personnel.

1.8 Pictogram explanation



DANGER

Type and source of danger

This indicates a **direct** dangerous situation that could lead to death or **serious injury** (highest danger level).

- Avoid danger by observing the valid safety regulations.



WARNING

Type and source of danger

This indicates a **potentially** dangerous situation that could lead to death or **serious injury** (medium danger level).

- Avoid danger by observing the valid safety regulations.



CAUTION

Type and source of danger

This indicates a **potentially** dangerous situation that could lead to slight or serious injury, damage or **environmental pollution** (low danger level).

- a) Avoid danger by observing the valid safety regulations.



NOTICE

Note / advice

This indicates useful information of advice for efficient and smooth operation.

2 Product and functional description

2.1 Lieferumfang

- Digital differential pressure transmitter
- User Manual

2.2 Intended use

The differential pressure transmitter DE49##0###BH00M# allows the measurement of under-pressure, over-pressure and differential pressure in dry neutral and gaseous media.

Fields of application include

- Air-conditioning technology
- Ventilation technology
- Environmental technology

Explosion hazard area classification

The differential pressure transmitter DE49##0###BH00M# is suitable as an electrical device for operation in potentially explosive areas.

- The device must be installed in Zone 1 or 2 or Zone 21 or 22.
- The pressure connections may be connected with Zone 0.
- The power circuit must satisfy the ignition protection category "Intrinsic safety" category "ia".
- Designation as per guideline 2014/34/EU.

⊕ II 1/2G Ex ia IIC T4 Ga/Gb

⊕ II 2D Ex ia IIIC T80°C Db

-10 °C ≤ Ta ≤ +60°C

2.3 Equipment versions

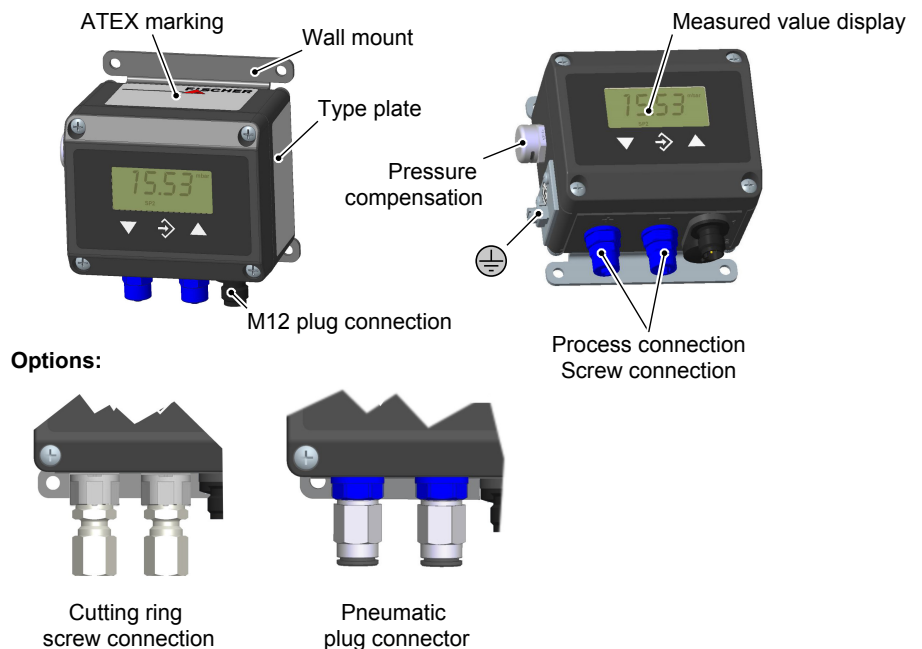

Fig. 1: Equipment versions DE49##0

2.3.1 Type plate

The presented type plates serve to show an example of the information shown. The data shown is purely fictive, but does correspond to the actual conditions. For more information, please see the order code at the end of these instructions.

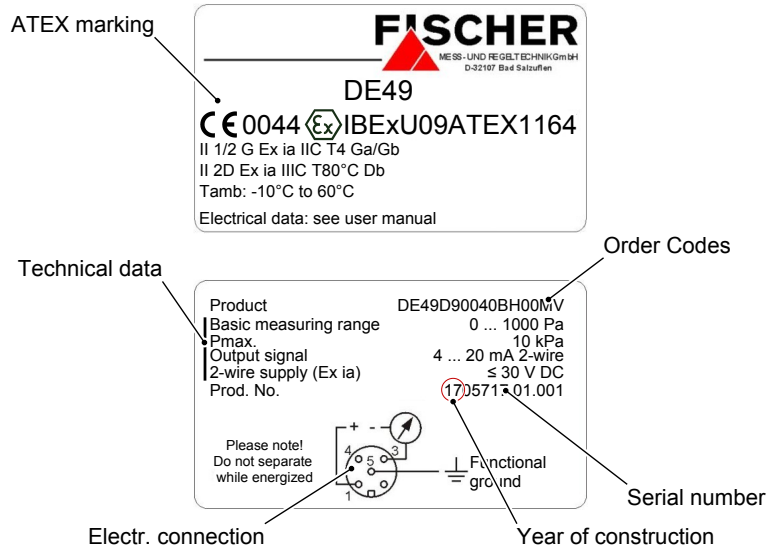

Fig. 2: Nameplate

2.4 Function diagram

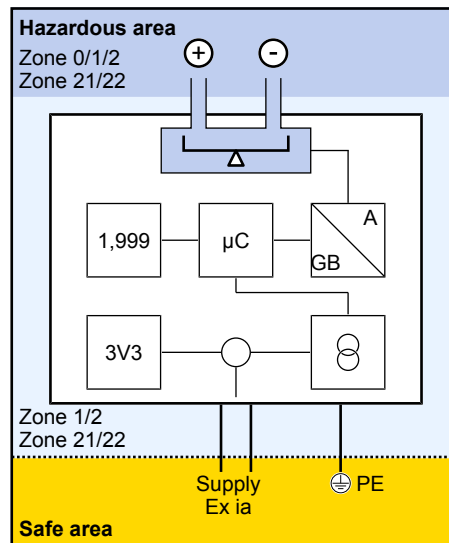

Fig. 3: Function diagram

2.5 Design and mode of operation

This switching device is based on a piezo-resistive sensor element that is suitable for measuring overpressure, underpressure and differential pressure.

The pressure acts on the silicone membrane of a semiconductor chip which in turn deforms. The specific material resistance changes proportionally to the deformation.

The electronics inside the pressure transmitter casing now convert this resistance change into an electrical output signal, calculate the pressure measurement and display this on the LC display.

The optional output signal can be dampened, spread and inverted.

3 Assembly

3.1 General

The device is designed for installation onto flat assembly plates. For screw connection to the assembly plate, the device features four assembly bores on its back, which can be used for \varnothing 3.5 mm tapping screws.

Optionally, the device can be delivered with a wall-mounting plate. This is also available as accessory.

At the factory, the device is calibrated for vertical installation, but the installation position is arbitrary. For any installation positions that are not vertical, the zero-point signal can be corrected via the installed offset correction.

The enclosure protection type IP 65 is only guaranteed, if a suitable power supply cable is used (see accessories).

If the device is intended for outdoor use, we recommend permanently protecting the membrane keypad against UV radiation and using a suitable enclosure or at least the erection of a sufficiently dimensioned canopy as a protection measure against constant rain or snow.



WARNING

Falling objects

The operator must ensure that any falling objects cannot collide with the installed unit. Steps must be taken to prevent

- ✓ sparks being generated on impact.
- ✓ the protection class of the casing is no longer guaranteed.
 - a) This can be avoided by attaching protective cover,
 - b) a protective casing or
 - c) a similar element.

3.2 Process connection

The process connection may only be realised by authorised and qualified specialists that have undergone additional training or briefings or have a permit to work on explosion-protected units in potentially explosive systems.

Risks emanating from pressure on the instrument should be prevented by means of suitable action.

- The device may only be installed in Zone 1 or 2 or Zone 21 or 22.
- The process connection may only be connected with Zone 0.
- The pipes need to be depressurized when the instrument is being connected.
- Appropriate steps must be taken to protect the device from pressure surges.
- Check that the device is suitable for the medium being measured.
- Check whether the allowed maximum pressures and temperatures are observed.



CAUTION

Do not blow into the pressure connections.

This may damage the sensor.

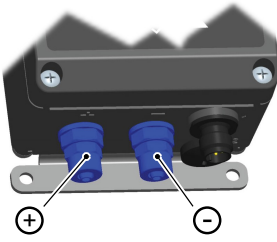

Fig. 4: Process connection

The pressure lines must be installed at an inclination so that no water pockets are created. If the required gradient is not reached, water filters need to be installed at suitable points.

The pressure lines must be kept as short as possible and installed without any tight bends to avoid delays.

If the pressure sensing lines are already pressurised at the time of commissioning, zero-point control and adjustment cannot be performed. In such cases, the device should be only connected to the mains without the pressure sensing lines.

The device has several connection options for the process connection. There must be appropriate hoses and pipes available on the system side.

The process connections are marked with (+) and (-) symbols on the device. The pressure lines must be mounted according to these symbols.

1. Differential pressure measurement

- ⊕ Higher pressure
- ⊖ lower pressure

2. Pressure measurement

- ⊕ Pressure
- ⊖ open

3. Under-pressure measurement

- ⊕ open
- ⊖ Under-pressure

3.3 Electrical connections

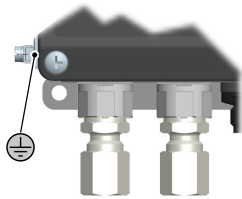

Fig. 5: Ground connection

The electrical connection may only be realised by authorised and qualified specialists that have undergone additional training or briefings or have a permit to work on explosion-protected units in potentially explosive systems.

Risks emanating from electrical current or voltage should be prevented by means of suitable action.

- When connecting the unit, the national and international electro-technical regulations must be observed.
- Disconnect the system from the mains, before electrically connecting the device.
- Do not connect the connector if strained.
- A CE-conform mains adapter with a slow 200 mA fuse only may be used in the power supply circuit.
- To ensure safe operation of the device, the power circuit must satisfy the ignition protection category "**Intrinsic safety**" category "**ia**" (see Technical data).



⚠ WARNING

Static electricity

The housing is made of a conductive plastic. To discharge any static charging, the housing must be grounded

The ground terminal is suitable for connecting fine-wire conductors up to 4 mm² or single-wire conductors up to 6 mm².

2-conductor circuit

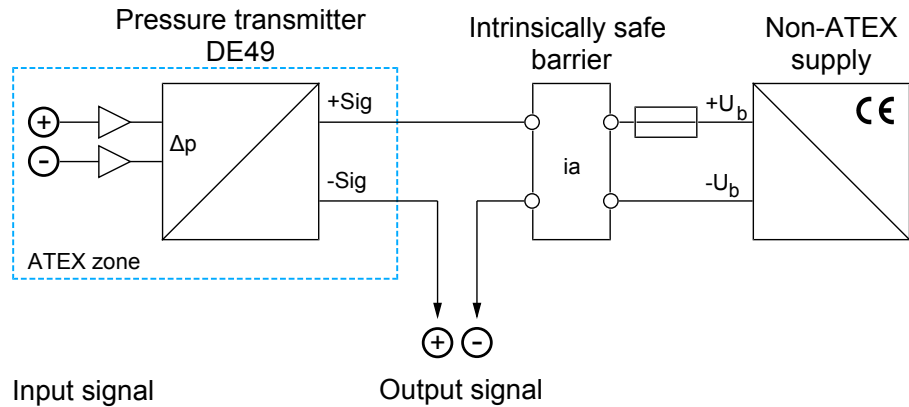

Fig. 6: 2L Circuitry

Supply and signal power circuit limit values

(Ignition protection type intrinsic safety Ex ia IIC)

	U_i	$\leq 30\text{ V}$
	I_i	$\leq 100\text{ mA}$
	P_i	$\leq 750\text{ mW}$
inner effective capacity	C_i	2.5 nF
effective inner inductivity	L_i	negligible

NOTICE! In contrast to the EMV-GND, the power connections have an inner capacity of max. 5 nF.

Pin assignment

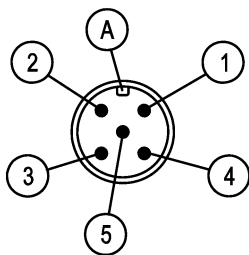

Fig. 7: M12 connector 5-pin

Pin	Signal name			Cable colour
1	Supply (+) / output (+)	+U _b	+Sig	brown
2	unused	n.c.		white
3	Supply (-) / output (-)	-U _b	-Sig	blau
4	unused	n.c.		schwarz
5	Functional earth			green/yellow
A	Coding A			

Tab. 1: Supply and output signal

4 Commissioning

4.1 Generalities



⚠ WARNING

Operation in areas at risk of explosion

If operated in explosive areas, the electrical data of the unit and the valid local regulations and guidelines for the installation and operation of electrical systems in explosive areas must be observed (e.g. DIN EN 60079-14)

A prerequisite for commissioning is correct installation of all electrical supply lines and the pressure lines. All connections are arranged so that there are no mechanical forces acting on the device.

4.2 Control elements

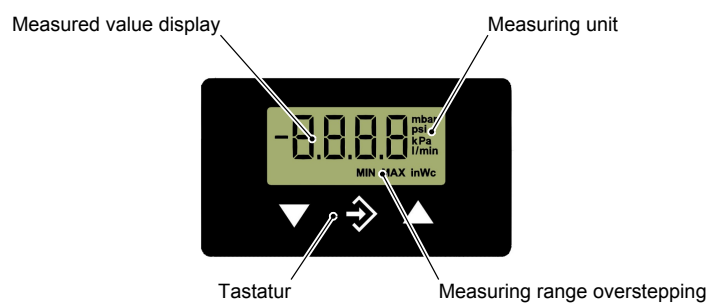

Fig. 8: Display and keypad

The LCD display shows the current pressure value in normal mode. The unit is shown to the right of the measured value.

It is operated via a 3-key film keypad

▼	Page down menu	Decrease value	
↵	Call up menu	Save value	OK
▲	Page up menu	Increase value	

4.3 Parameters

After being activated, the device briefly displays the software version number and carries out a display test. Then the transmitter goes into normal mode.

When setting the parameters, the display either shows the respective menu item or the associated parameter value. The device continues to function whilst the parameters are being set; the changes come into effect instantly.

Please note that the transmitter will switch to the operating mode again, if no key is pressed for more than 1 minute.

Proceed as follows to set a parameter:

- Press the enter key ↵ to switch to the menu. *ESC* will appear on the display.
- Use the arrow keys ▲ to select the first parameter.
- If a password has been entered, *-P-* appears in the display. Enter the password to unlock the menu.
- Use the arrow keys ▼ ▲ to scroll through the menu.
- Press the enter key ↵ to call up the parameter.
- Use the arrow keys ▼ ▲ to set the required value.
- Press the enter key ↵ to save the value.

After setting all parameters, leave the menu as follows:

- Use the arrow keys \blacktriangledown \blacktriangle to set the $E5C$ parameter. You will find these at the start and also at the end of the menu.
- Press the enter key \Rightarrow to leave to the menu.

4.3.1 Zero point control and adjustment

Ensure that the device is not pressurised (if necessary, disconnect any pressure lines). If the device does precisely indicate zero at this point of time, parameter OFF enables you to adjust the measuring value exactly to zero.

After zero-point adjustment, any disconnected pressure sensing lines can be re-connected.

4.3.2 Damping and zero-point stabilising

If there are unsteady pressure readings at this point of time or during operation, you can use parameters dRN and nP to stabilise the reading (and the output signal).

The parameter dRN functions like a capillary throttle. However, it only acts on the display and output signal but not on the measuring cell itself. You can set the response time to pressure jumps with this parameter. The value range is 0.0 s to 200.0 s.



NOTICE

Maximum damping

But with maximum damping, it will take more than 2 minutes for the reading also to reach zero after a pressure jump from nominal pressure (100 %) to zero!

In many cases, unsteady readings are not a problem during normal operating mode, but this is not true for the idle state, i.e. if zero (differential) pressure is expected.

In such situations, parameter nP can be used. Its value defines a range of measurement range around zero. The measured value is set to zero within this range.

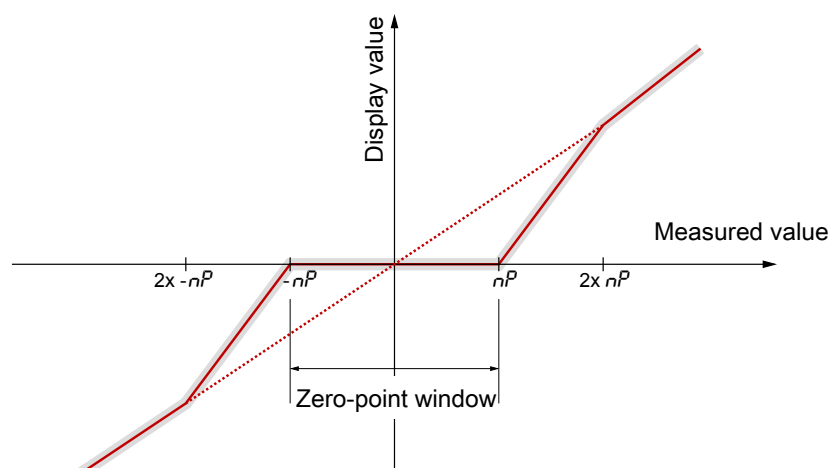

Fig. 9: Zero-point window

Example:

A value of 0.08 mbar is entered for nP . In this case all pressures within the range of -0.08 mbar to +0.08 mbar are set to zero on the display. The reading will only not indicate zero any more if the pressure exceeds these limits. However the pressure value and display do not correspond to one hundred percent. The measuring pressure and reading match again when the double value, in this case 0.16 mbar, is reached again.

4.3.3 Margin correction

The parameter SPR_n is used to correct the measuring range span. The current measurement is shown. Using the arrow keys, this can be changed by up to $\pm 10\%$ of the basic measuring range. Keep the arrow keys pressed until the required value is shown.

4.3.4 Unit

The parameter E_{In} is used to select one of the following units.

Value	Einheit
1	bar
2	mbar
3	PA
4	kPa
5	psi
6	inWc

If the support point table function is used, the measurement is shown without a unit.

4.3.5 Setting the output signal

Within the basic measuring range (see type plate) the measuring range can be modified using the parameters NR (measuring range start) und NE (measuring range end). Both values are adjustable across the entire basic measuring range. The set values always refer to pressure (in the relevant measuring unit) and are converted when the measuring unit is changed.

If the pressure signal oversteps the set values, this is shown on the display with **MAX** or **MIN**.

The difference between values NR and NE must at least be 25 % of the basic measuring range. The software does not allow any larger spreads (Turndown 4:1). If the range information is stated wrongly, you cannot leave the menu.

- If $NR < NE$, the characteristic curve rises. The output signal grows as the pressure increases.
- If $NR > NE$, the characteristic curve drops. The output signal drops as the pressure increases.

4.3.6 Output signal limits (NAMUR)

Regardless of the pressure, the three parameters $IG1$, $IG2$ and IEr define the limit values for output signal that may not be undercut or exceeded.

These limit values take precedence over the range defined by the NR and NE . These parameters primarily serve to prevent error messages in downstream systems caused by brief overstepping of measuring ranges.

The parameter $IG1$ defines the limit value for the minimum output signal. The output signal may not undercut this value.

The parameter $IG2$ defines the limit value for the maximum output signal. The output signal may not exceed this value.

The parameter IEr defines the value for the error signal. The value defined via the parameter IEr , e.g. 3.8 mA, is issued if the device detects an internal error and can no longer work correctly. However, not all possible errors and defects can be detected by the device.

4.3.7 Function selection

The parameter allows you to select between the following functions:

- $F=0$
The device works as a linear transmitter.
- $F=1$
causes a rooting of the output signal and the display.
- $F=3 \dots 30$
causes linearization of the output and display based on a support point table.



NOTICE

Changing the parameter value

Whenever you change the value from F the program creates a new table. All previous values in the table are rejected and replaced with new linear entries.

Rooted output signal

$F=1$ causes a rooting of the output signal and the display. The menu shows the parameters dPF , nRF , nEF and nEd . The display can be scaled infinitely with these parameters. The measured value is displayed without a unit and can therefore be assigned to any unit (free unit).

- The measuring range defined by the parameters nR and nE is converted to nRF and nEF .
- The value of dPF determines the position of a decimal point.
- The value must be set from nEd to 0.

Support point table

$F=3 \dots 30$ causes linearization of the output and display based on a support point table.

Also, a parameter $L In$ is shown behind which there is a submenu for entering value pairs of the support point table. This submenu has its own entry and exit point that is shown with End. The table is only saved if you return to the main menu at precisely this point, i.e. if you change to the parameter $L In$ in the main menu again via the key \leftrightarrow .

If the table is not structured correctly, an error message Err will appear here and you cannot quit the submenu.

The table comprises 3...30 pairs of values. The first value pair is $(I-01|P-01)$.

- The value $I-01$ defines the display value of the output signal level.
- The value $P-01$ determines the associated pressure.
- Followed by the pairs of values $\dots (I-02|P-02) \dots (I-30|P-30)$.

The output is proportional to the display value.

The table is correct if the following applies for all signal values: The value is larger than the previous value. Either larger (rising characteristic curve) or smaller (falling characteristic curve) apply to the pressure values accordingly. No transition from rising to falling characteristic curves or vice versa is allowed.

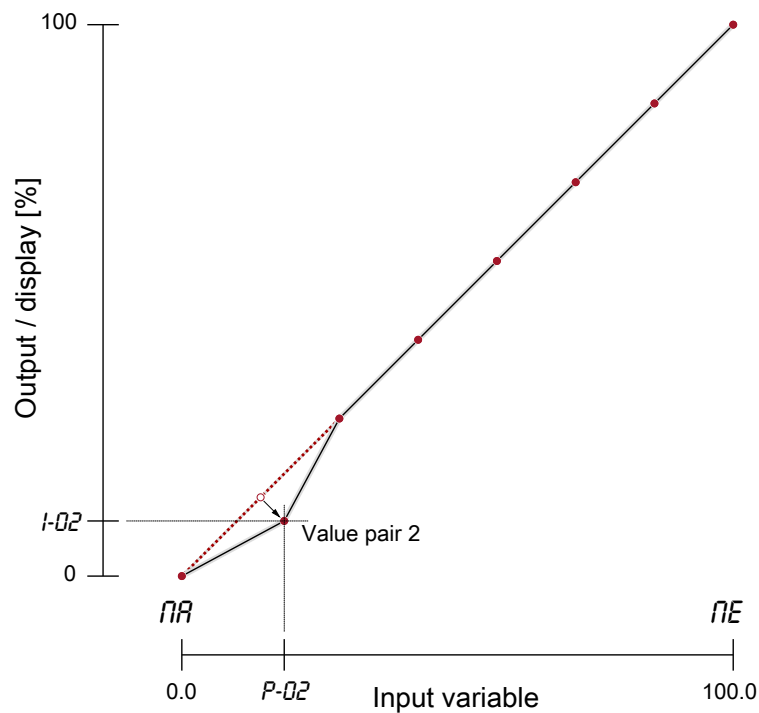

Fig. 10: Table function

4.3.8 Password

The parameter *PASS* serves to define a password.

A value between 0 and 999 can be selected for the password. The value 0 cancels the password function.

If a password has been issued, the unit configuration is protected by this password. You can use the key \diamond to switch to the configuration mode, however as soon as you select a parameter, a password request appears *-P-*. You can set this with the arrow keys \blacktriangle \blacktriangledown and confirm with \diamond . This unlocks the unit and it can be configured again.



NOTICE

Forgotten password

If the password is forgotten, it can only be deleted again by the manufacturer.

4.3.9 Reset

The function *r5t* allows all settings to be reset to default values. The default value for this parameter is 0.

Enter the value 1 to carry out a RESET. As soon as the configuration mode is quitted via the parameter *ESC*, a RESET is carried out and all parameters are reset to the saved default values.

4.3.10 Parameter menu

After switching on the device, it will briefly indicate the software version number and before entering the normal operating mode. By using the middle \hat{u} key on the membrane keypad you can access the parameter menu. The reading now shows the text *ESC*. By using the right \blacktriangle key, you can choose the parameters from the following list one by one.

ESC	menu start (OUTPUT)
NR	Start of measuring range Enter the pressure value here that corresponds to an output signal of 4mA. Max. turndown 4:1.
NE	End of measuring range Enter the pressure value here that corresponds to an output signal of 20mA. Max. turndown 4:1.
dRN	Damping measuring pressure To calm the pressure measurement, enter the minimum rising time (0 ... 200s) here.
on	Change unit bar, mbar, Pa, kPa, PSI, InWc
OFF	Offset correction Correct the measuring pressure to zero here. The display shows the current measured value that you can change by up to 1/3 of the basic range.
SPAN	Span correction Correct the pressure measurement span. The display shows the current measured value that you can change by up to ±10% of the basic range.
nP	Zero-point window Define a range around zero in which the measured value is permanently set to zero. Outside the range, the measured value is approached as shown in the figure Zero-point window [▶ 13].
F	Function selection <ul style="list-style-type: none"> • F=0 The device works as a linear transmitter. The parameters marked in red and blue are hidden. • F=1 causes a rooting of the output signal and the display. The parameters marked in red (dPF, MAF, MEF, MEd) and shown. • F=3 ... 30 causes linearization of the output and display based on a support point table. The parameter F states the number of support points (value pairs) in the table. The table can contain 3 to 30 support points. If the table is used, the parameters marked in red and blue (dPF, MAF, MEF, MED and LIN) are shown. The measured value is displayed without a unit and can therefore be assigned to any unit by the user using the additional parameters (free unit). <p>The measured value is displayed without a unit and can therefore be assigned to any unit by the user using the following parameters (free unit).</p>
dPF	Decimal point „free unit“ This parameter states the number of decimal points of the displayed measured value. Possible values are 0...3.

NAF**Start of measuring range "free unit"**

Defines the start of the free measuring range.

NEF**End of measuring range 'free unit'**

Defines the end of the free measuring. Maximum value: 9999.

NEd**Medium**

This parameter is always to set to 0.

L In**Support point table**

Define the support point table here.

Sub menu*End**I-01* Value pair 1
*P-01**I-02* Value pair 2
*P-02**I-03* Value pair 3
P-03

⋮

I-30 Value pair 30
*P-30***101****lower current limit**

Define the minimum output signal here (3.5 ... 22.5mA).

102**upper current limit**

Define the maximum output signal here (3.5 ... 22.5mA).

1Er**Error signal**

Define the output signal here (3.5 ... 22.5mA) that should be issued when there is an internal error in the device.

PASS**Password**

A value between 1 and 999 can be selected for the password. The value 0 deactivates the password function.

rSt**Reset**

This parameter value is set to 0. If this parameter is set to 1, all parameters are irrevocably reset to the default settings.

ESC**menu end (OUTPUT)**

5 Servicing

5.1 Maintenance

To ensure reliable operation and a long service life, we recommend carrying out the following test on a regular basis:

- Check the reading.
- Checking the switch function in connection with the downstream components.
- Checking the differential pressure lines for leaks.
- Checking the electrical connections (terminal connection of the cable).

The precise test cycles and operating and ambient conditions need to be adjusted. If several components of the unit interact, all operating instructions of the other units also need to be observed.



WARNING

Dust deposits

The device must be cleaned with a damp cloth a regular intervals to prevent heat build-up. Cleaning intervals depend on the amount of local dust.

5.2 Transport

The measuring device must be protected against impacts. It should be transported in the original packaging or a suitable transport container.

5.3 Service

All defective or faulty devices should be sent directly to our repair department. Please coordinate all shipments with our sales department.



WARNING

Process media residues

Process media residues in and on dismantled devices can be a hazard to people, animals and the environment. Take adequate preventive measures. If required, the devices must be cleaned thoroughly.

Return the device in the original packaging or a suitable transport container.

5.4 Disposal

Please help to protect the environment by always disposing of the work pieces and packaging materials in compliance with the valid national waste and recycling guidelines or reuse them.

6 Technical data

6.1 General

Please also observe the order code here.

6.2 Input variables

Measuring variable: Differential pressure for gaseous media

Measuring range			Stat. operating pressure max.	Bursting pressure
mbar	PA	kPa	mbar	mbar
0...4	0...400	---	50	150
0...6	0...600	---	50	150
0...10	0...1000	0...1.0	100	300
0...16	0...1600	0...1.6	100	300
0...25	---	0...2.5	250	750
0...40	---	0...4.0	250	750
0...60	---	0...6.0	500	1500
0...100	---	0...10.0	500	1500
±2.5	±250	---	50	150
±4	---	---	50	150
±6	---	---	50	150
±10	---	±1.0	100	300
±16	---	±1.6	100	300
±25	---	±2.5	250	750
±40	---	±4.0	250	750
±60	---	±6.0	500	1500
±100	---	---	500	1500

6.3 Output parameters

Outlet	Signal range	Apparent ohmic resistance
4...20 mA,	3.5...22.5 mA	$R_L \leq (U_b - 4 \text{ V})/0.02 \text{ A}$

6.4 Measurement accuracy

Characteristic curve deviation

(Non-linearity and hysteresis)

Maximum: 1.0 % FS

Typical: 0.5 % FS

The information refers to a linear, non-spread characteristic curve at 25 °C and applies to all measuring ranges. FS (Full Scale) refers to the basic measuring range.

Temperature coefficient (TK)

Measuring range	TK zero-point [% FS/10K]		TK span [% FS/10K]	
	mbar	typ.	max.	typ.
0...4	0.2	1.0	0.3	1.0
0...6	0.2	1.0	0.3	1.0
0...10	0.2	0.4	0.3	0.3
0...16	0.2	0.4	0.3	0.3
0...25	0.2	0.4	0.3	0.3
0...40	0.2	0.4	0.3	0.3
0...60	0.2	0.4	0.3	0.3
0...100	0.2	0.4	0.3	0.3
0...160	0.2	0.4	0.3	0.3
0...250	0.2	0.4	0.3	0.3
±2.5	0.2	1.0	0.3	1.0
±4	0.2	0.5	0.3	0.5
±6	0.2	0.4	0.3	0.3
±10	0.2	0.4	0.3	0.3
±16	0.2	0.4	0.3	0.3
±25	0.2	0.4	0.3	0.3
±40	0.2	0.4	0.3	0.3
±60	0.2	0.4	0.3	0.3
±100	0.2	0.4	0.3	0.3

With reference to the basic measuring range (FS), Compensation range 0..60°C.

6.5 Display and control elements**Display**

4-digit LC display stating the measuring unit

Keyboard

Foil keypad with 3 buttons

Programming

Attenuation	0.0 ... 100.0 s (jump response time 10 / 90 %) for signal output; separately also for display
Measuring range unit	mbar, bar, Pa, KPa, PSI and inWc
Start / end of measuring range	User-definable within the basic measuring range ⁽¹⁾
Output signal	can be set anywhere within the signal range
Zero-point stabilising	Zero-point window max. 1/3 of the basic measuring range ⁽²⁾
Zero point correction	±1/3 of the basic measuring range ⁽³⁾
Implementation of characteristic curve	Linear, rooted, max. 4:1 spread, inverted
Password	1 ... 999 (0 = no password protection)

(1) Max. effective spread 4:1

(2) measured values around zero are set to zero.

(3) Zero-point correction to compensate different installation positions.

6.6 Auxiliary energy

The unit power supply may only be an inherently safe power circuit of the ignition protection type 'Ex ia IIC'.

Rated Voltage	24v DC
Admissible operating voltage	12 ... 30 V
Current limitation	≤ 22.5 mA (can be programmed)

Supply and signal power circuit limit values

(Ignition protection type intrinsic safety Ex ia IIC)

	U_i	≤ 30 V
	I_i	≤ 100 mA
	P_i	≤ 750 mW
inner effective capacity	C_i	2.5 nF
effective inner inductivity	L_i	negligible

NOTICE! In contrast to the EMV-GND, the power connections have an inner capacity of max. 5 nF.

6.7 Application conditions

Ambient temperature	-10 ... +60 °C
Media temperature	-10 ... +60 °C
Storage temperature	-20 ... +70 °C
Enclosure protection class	IP65 as per EN 60529
EMC	EN 61326-1:2013 EN 61326-2-3:2013
RoHS	EN 50581:2012
ATEX	EN 60079-0:2012 + A11:2013 EN 60079-11:2012

ATEX classification

Type testing	IBExU09ATEX1164
Zone 1 and 2	⊕ II 1/2G Ex ia IIC T4 Ga/Gb
Zone 21 and 22	⊕ II 2D Ex ia IIIC T80°C Db

6.8 Construction design

Process connection

Aluminium hose screw connection for 6/4 or 8/6 mm hose
Cutting ring screw connection in brass for 6 or 8 mm pipe
Pneumatic plug connector for 6/4 or 8/6 mm hose

Materials

Housing	Polyamide (PA) 6.6 , electrically conductive
Media-contacting material	Silicon, Viton®, aluminium, brass

Assembly

- Attachment boreholes on the rear side for attachment to mounting plates.
- Wall mounting using wall mounting plate
- Panel mounting set for installing the panel
- Assembly of the mounting rails using an adapter

Dimensional drawings

All dimensions in mm unless otherwise stated

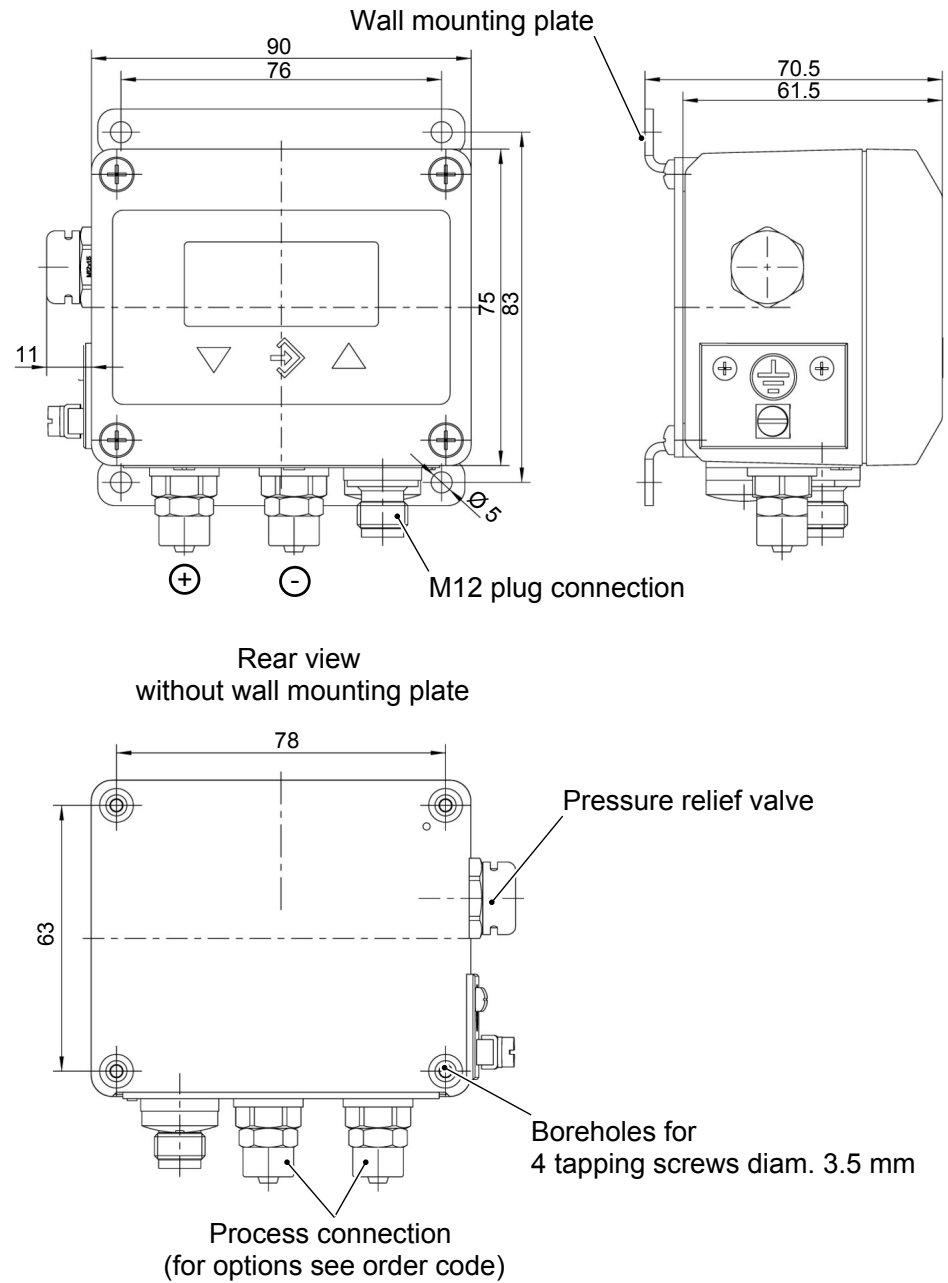

Fig. 11: Dimensional picture

Panel mounting set

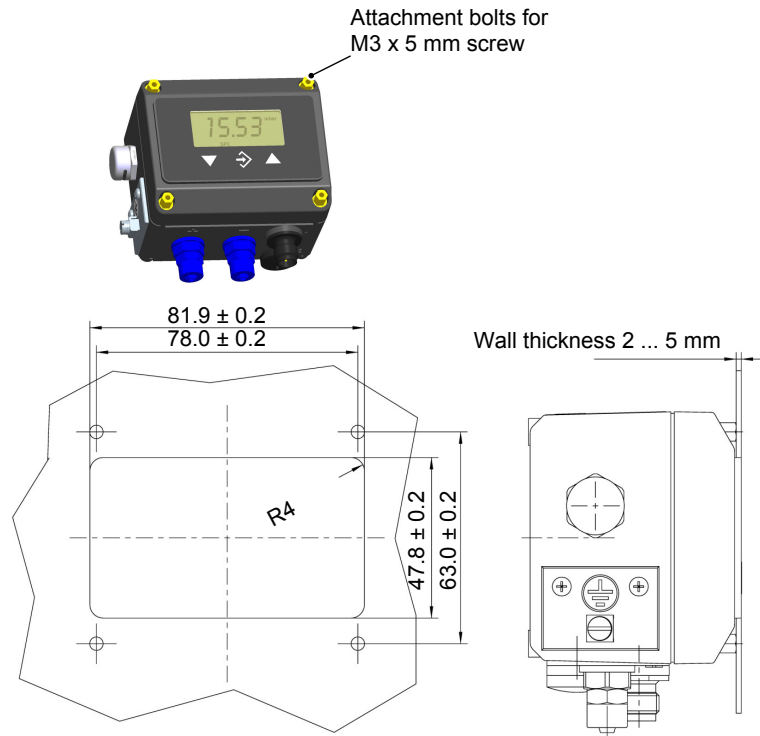

Fig. 12: Panel mounting set

Assembly of the mounting rails

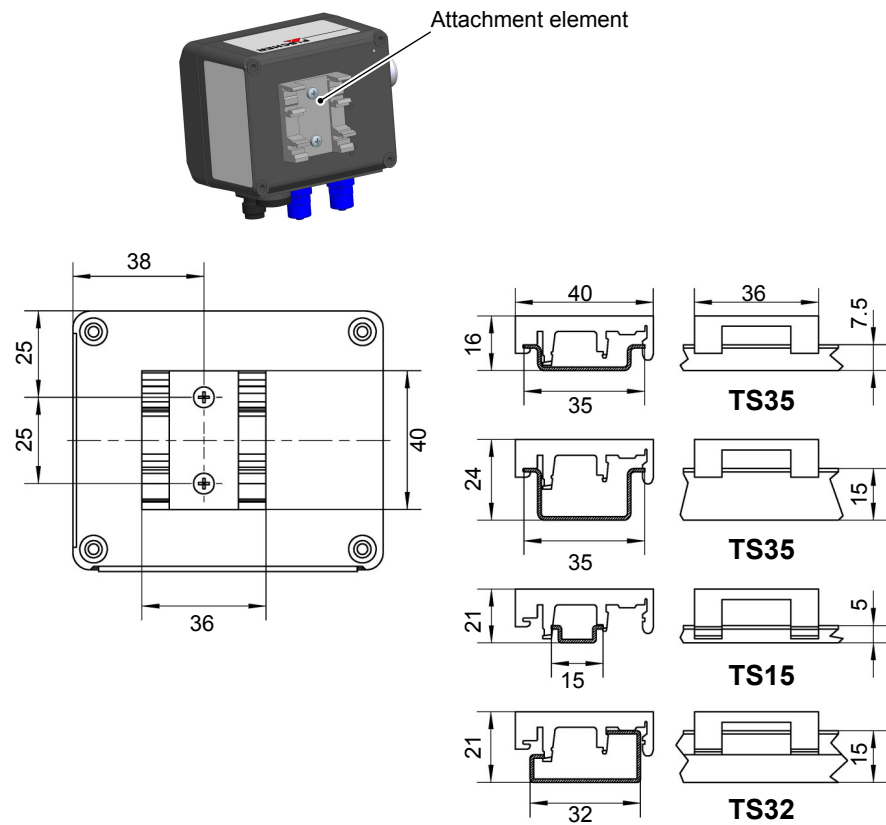
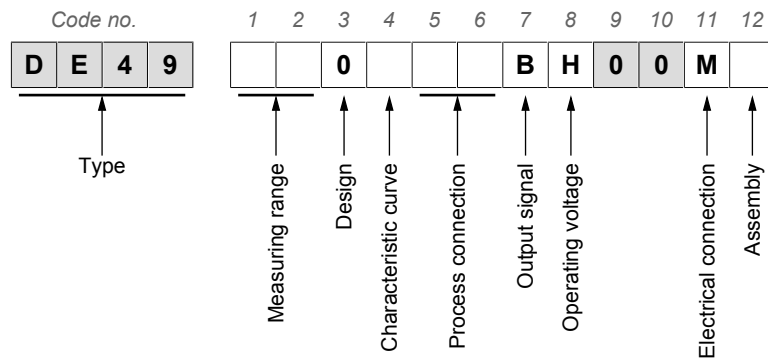

Fig. 13: Assembly of the mounting rails

7 Order Codes



[1.2]	Measuring range	Static operating pressure
52	0 ... 4 mbar	50 mbar
53	0 ... 6 mbar	50 mbar
54	0 ... 10 mbar	100 mbar
55	0 ... 16 mbar	100 mbar
56	0 ... 25 mbar	250 mbar
57	0 ... 40 mbar	250 mbar
58	0 ... 60 mbar	500 mbar
59	0 ... 100 mbar	500 mbar
A6	-2.5 ... +2.5 mbar	50 mbar
A7	-4 ... +4 mbar	50 mbar
A8	-6 ... +6 mbar	50 mbar
A9	-10 ... +10 mbar	100 mbar
B1	-16 ... +16 mbar	100 mbar
B2	-25 ... +25 mbar	250 mbar
C5	-40 ... +40 mbar	250 mbar
B3	-60 ... +60 mbar	500 mbar
B4	-100 ... 100 mbar	500 mbar
D7	0 ... 400 Pa	5 kPa
D8	0 ... 600 Pa	5 kPa
D9	0 ... 1000 Pa	10 kPa
E1	0 ... 1600 Pa	10 kPa
L6	-250 ... +250 Pa	5 kPa
N1	0 ... 1 kPa	10 kPa
N2	0 ... 1.6 kPa	10 kPa
N3	0 ... 2.5 kPa	25 kPa
N4	0 ... 4 kPa	25 kPa
N5	0 ... 6 kPa	50 kPa
E5	0 ... 10 kPa	50 kPa

[1.2]	Measuring range	Static operating pressure
L8	-1 ... +1 kPa	10 kPa
L9	-1.6 ... +1.6 kPa	10 kPa
M6	-2.5 ... +2.5 kPa	25 kPa
M7	-4 ... +4 kPa	25 kPa
M8	-6 ... +6 kPa	50 kPa

[3]	Design
0	Standard version

[4]	Characteristic curve
0	linear rising (standard)
R	root extracted

[5.6]	Process connection
40	Aluminum screw connection for 6/4 mm hose
41	Aluminum screw connection for 8/6 mm hose
28	Cutting ring screw connection made of Brass for 6 mm tube
29	Cutting ring screw connection made of Brass for 8 mm tube
P6	Pneumatic plug connector for 6/4 mm hose
P8	Pneumatic plug connector for 8/6 mm hose

[7]	Output signal
B	4 ... 20 mA 2-wire connection

[8]	Operating voltage
H	24V DC (12 ... 30 V DC)

[11]	Electrical connection
M	M12 plug connection

[12]	Assembly
0	Attachment boreholes on rear side (standard)
S	Assembly of the mounting rails
T	Board mounting set
W	Wall mounting

7.1 Accessories

Order no.	Designation	No. of Poles	length
06401685	Connection cable with M12 connector	5 pin	2 m
06401686	Connection cable with M12 connector	5 pin	5 m
06401687	Connection cable with M12 connector	5 pin	7 m
06401688	Connection cable with M12 connector	5 pin	15 m

8 Attachments

8.1 EU Declaration of Conformity



EC Declaration of Conformity

(Translation)

For the product described as follows

Product designation **Digital Differential Pressure Transmitter
with external Sensor**

Type designation **DE49 ## 0 ### BH00M #**

it is hereby declared that it corresponds with the basic requirements specified in the following designated directives:

2014/30/EU	EMC Directive
2014/34/EU	ATEX Directive
2011/65/EU	RoHS Directive

The products were tested in compliance with the following standards.

	Electromagnetic compatibility (EMC)
EN 61326-1:2013	Electrical equipment for measurement, control and laboratory use - EMC requirements - Part 1: General requirements
EN 61326-2-3:2013	Electrical equipment for measurement, control and laboratory use - EMC requirements - Part 2-3: Particular requirements - Test configuration, operational conditions and performance criteria for transducers with integrated or remote signal conditioning
	Explosive atmospheres (ATEX)
EN 60079-0:2012 + A11:2013	Explosive atmospheres - Part 0: Equipment - General requirements
EN 60079-11:2012	Explosive atmospheres - Part 11: Equipment protection by intrinsic safety "i"
	RoHS
EN 50581:2012	Technical documentation for the assessment of electrical and electronic products with respect to the restriction of hazardous substances

The notified office IBEXU- INSTITUT FÜR SICHERHEITSTECHNIK GMBH INSTITUT AN DER TECHNISCHEN UNIVERSITÄT - BERGAKADEMIE FREIBERG NB **0637** performed the CE-type examination and issued the following certificate: **IBExU09ATEX1164**

The notified office TÜV NORD CERT GmbH NB **0044** is responsible for monitoring the QS Management.

Also they were subjected to the conformity assessment procedure „**Internal Control of Production**“.





Sole responsibility for the issue of this declaration of conformity in relation to fulfilment of the fundamental requirements and the production of the technical documents is with the manufacturer.

Manufacturer **FISCHER Mess- und Regeltechnik GmbH**

Bielefelderstr. 37a
32105 Bad Salzufen, Germany

Tel. +49 5222 974 0

**Documentation
representative**

Herr Stefan Richter
Dipl. Ing.
Development manager

**The devices bear the
following marking:**

 0044

 II 1/2G Ex ia IIC T4 Ga/Gb

 II 2D Ex ia IIIC T80°C Db
-10 °C ≤ T_a ≤ +60°C

**Bad Salzufen,
2017-02-15**

S. Richter
General Manager R&D

09010094 CE EN DE49##A Rev.B 06/17



8.2 ATEX type testing

IBExU Institut für Sicherheitstechnik GmbH An-Institut der TU Bergakademie Freiberg

[1] EU-TYPE EXAMINATION CERTIFICATE - Translation



- [2] Equipment or protective systems intended for use in potentially explosive atmospheres, Directive 2014/34/EU
- [3] EU-type examination certificate number **IBExU09ATEX1164** | Issue 1
- [4] Product: **Differential pressure transmitter types DE49 ## 0 and DE49 ## A**
- [5] Manufacturer: Fischer Mess- und Regeltechnik GmbH
- [6] Address: Bielefelder Str. 37a
32107 Bad Salzufen
GERMANY
- [7] This product and any acceptable variations thereto are specified in the schedule to this certificate and the documents therein referred to.
- [8] IBExU Institut für Sicherheitstechnik GmbH, notified body number 0637 in accordance with Article 17 of Directive 2014/34/EU of the European Parliament and of the Council, dated 26 February 2014, certifies that this product has been found to comply with the essential health and safety requirements relating to the design and construction of products intended for use in potentially explosive atmospheres given in Annex II to the Directive.
- The examination and test results are recorded in the confidential test report IB-17-3-0035.
- [9] Compliance with the essential health and safety requirements has been assured by compliance with: EN 60079-0:2012+A11:2013 EN 60079-11:2012 EN 60079-26:2015 except in respect of those requirements listed at item [18] of the schedule.
- [10] If the sign "X" is placed after the certificate number, it indicates that the product is subject to the specific conditions of use specified in the schedule to this certificate.
- [11] This EU-type examination certificate relates only to the design and construction of the specified product. Further requirements of the Directive apply to the manufacturing process and supply of this product. These are not covered by this certificate.
- [12] The marking of the product shall include the following:

II 1/2G Ex ia IIC T4 Ga/Gb
II 2D Ex ia IIIC T80 °C Db
 -10 °C ≤ Ta ≤ +60 °C

IBExU Institut für Sicherheitstechnik GmbH
Fuchsmühlenweg 7
09599 Freiberg, GERMANY

By order

(Dipl.-Ing. [FH] Henker)



Seal -
(notified body number 0637)

Tel: + 49 (0) 37 31 / 38 05 0
Fax: + 49 (0) 37 31 / 38 05 10

Certificates without signature and seal are not valid. Certificates may only be duplicated completely and unchanged. In case of dispute, the German text shall prevail.

Freiberg, 2017-07-07

Fig. 16: IBExU09ATEX1164(2)_EN_Part1

IBExU Institut für Sicherheitstechnik GmbH
An-Institut der TU Bergakademie Freiberg

[13] **Schedule**

[14] **Certificate number IBExU09ATEX1164 | Issue 1**

[15] **Description of product**

The differential pressure transmitter types DE 49 ## 0 and DE49 ## A with process connections is intended for the pressure measurement in potentially explosive areas of category 1/2G under atmospheric conditions (temperature of -10 °C up to +60 °C, pressure of 0.8 bar up to 1.1 bar).

The electronic module is installed in a dissipative plastic enclosure with LCD display and foil buttons and can be used in zone 1 and zone 21, respectively. The measurement device is connected to the zone 0 by pneumatic screw- or plug connection.

The differential pressure transmitter is supplied via M12 plug connector by an intrinsically safe power supply of category "ia" and provides an electrical output current proportional to the differential pressure.

Ambient temperature range: $-10\text{ °C} \leq T_a \leq +60\text{ °C}$

Supply and signal circuit	type of protection intrinsic safety Ex ia IIC
Circuit diagram (LA1 and LA2)	U _i 30 V
	I _i 100 mA
	P _i 750 mW
Effective internal capacitance	C _i 2.5 nF
Effective internal inductance	L _i negligible

The supply connections have an internal capacitance of max. 5 nF related to the EMC-GND.

Type-key:

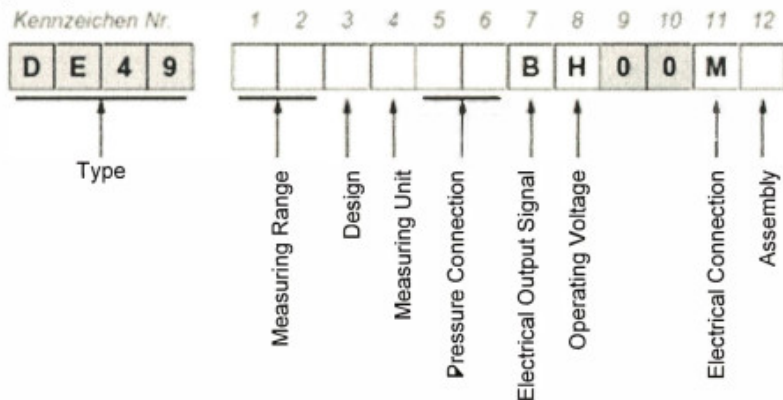

- [1,2] Measuring Range, Max. Stat. Operating Pressure
Design 0 : 50 mbar ... 500 mbar or 5 kPa ... 50 kPa
Design A : 250 mbar ... 3 bar
- [3] Design: 0 Standard
Design: A Encapsulated sensor up to 3 bar
- [4] Measuring Unit: 0 – linear/increasing curve (standard), R - extracted root
- [5,6] Pressure Connection:
00 Standard
40 Aluminium screw connection for 6/4 mm hose
41 Aluminium screw connection for 8/6 mm hose
24 Cutting ring screw connection made of 1.4571 for 6 mm pipe (Design A)
25 Cutting ring screw connection made of 1.4571 for 8 mm pipe (Design A)
P6 Pneumatic plug connector for 6/4 mm hose (new)
P8 Pneumatic plug connector for 6/4 mm hose (new)
- [7] Electrical Output Signal: B 4 ... 20 mA

Fig. 17: IBExU09ATEX1164(2)_EN_Part2

IBExU Institut für Sicherheitstechnik GmbH

An-Institut der TU Bergakademie Freiberg

- [8] Operating Voltage: H 24 VDC (12 ... 30 V DC)
 [11] Electrical Connection: M - M12 Plug connection
 [12] Assembly:
 O Rear wall-fastening panel (standard)
 S Mounting rail assembly
 T Console installation set
 W Wall mounting

Variations compared to issue 0 of this certificate:

Compared to the basic-version a new pneumatic plug has been added.

The in the ATEX-approval IBExU09ATEX1164 considered requirements which result from EN 61241-0:2006 and EN 61241-11:2006 has been incorporated in EN 60079-0:2012+A11:2013 and EN 60079-11:2012. The fulfillment of the requirements of the current standards has been examined.

[16] Test report

The test results are recorded in the confidential test report IB-17-3-0035 of 2017-07-07.

The test documents are part of the test report and they are listed there.

Summary of the test results

The differential pressure transmitter types DE 49 ## 0 and DE49 ## A fulfils the requirements of protection type intrinsic safety on an explosion protected apparatus of group II, category 1/2G as well as category 2D.

[17] Specific conditions of use

None

[18] Essential health and safety requirements

In addition to the essential health and safety requirements (EHSRs) covered by the standards listed at item [9], the following are considered relevant to this product, and conformity is demonstrated in the test report: none

[19] Drawings and Documents

The documents are listed in the test report.

IBExU Institut für Sicherheitstechnik GmbH
 Fuchsmühlenweg 7
 09599 Freiberg, GERMANY

By order



(Dipl.-Ing. [FH] Henker)

Freiberg, 2017-07-07

Fig. 18: IBExU09ATEX1164(2)_EN_Part3