

Operating manual

ME05 | Pressure transducer

Table of contents

1	Safety notes
2	Application purpose
3	Description of the product and function
4	Mounting and Installation
5	Commissioning
6	Maintenance
7	Transport
8	Service
9	Accessories
10	Disposal
11	Technical data
12	Dimensional drawings
13	Order Codes



1 Safety notes

1.1 General



This operating manual contains instructions fundamental to the installation, operation and maintenance of the device that must be observed unconditionally. It must be read by the assembler, operator and the specialized personnel in charge of the instrument before it is installed and put into operation. This operating manual must always be kept in an easily accessible place at the place of installation.

The subsequent sections on general safety instructions (1.2 - 1.7) as well as the following special instructions in particular about assembly, commissioning and maintenance (2 to 10) contain important safety instructions, the non-observance of which can endanger persons, animals, and physical objects.

1.2 Personnel Qualification

Staff assigned to assembly, operating, maintenance and inspection tasks shall be adequately qualified for this work and must be sufficiently instructed and trained to meet the requirements of assembly, operating, maintenance and inspection work.

1.3 Risks due to Non-Observance of Safety Instructions

Non-observance of these safety instructions, the intended use of the device or the limit values given in the technical specifications can be hazardous or cause harm to persons, the environment or the plant itself. Fischer Mess- und Regeltechnik GmbH will not be liable for damage claims if this should happen.

1.4 Safety Instructions for the Operating Company and the Operator

The safety instructions governing correct operation of the instrument must be observed. The operating company must make them available to the installation, maintenance, inspection and operating personnel. Dangers arising from electrical components, energy discharged by the medium, escaping medium and incorrect installation of the instrument must be eliminated. The particulars can be found in the respective regulations such as DIN EN, explosion hazard, accident prevention regulations and also in the industry guidelines issued by the DVWG, GL, etc. and the VDE as well as the local EVUs.

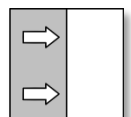

1.5 Unauthorised Modification

Modifications of or other technical alterations to the instrument by the customer are not permitted. This also applies to the installation of spare parts that are not explicitly described in the Operating Instructions. Any modifications / alterations required must be carried out by Fischer Mess- und Regeltechnik GmbH only.

1.6 Inadmissible Modes of Operation

The operational safety of this instrument can only be guaranteed if it is used as intended. The instrument model must be suitable for the medium used in the system. The limit values given in the technical data may not be exceeded.

1.7 Safe working practices for maintenance and installation work

The safety instructions given in this operating manual, any nationally applicable regulations on accident prevention and any of the operating company's internal work, operating and safety guidelines must be observed.

The operating company is responsible for ensuring that all required maintenance, inspection and installation work is carried out by qualified specialized personnel.

1.8 Pictogram explanation



WARNING!

... indicates a potentially dangerous situation, non-observance of which could endanger persons, animals, the environment or objects.

2 Application purpose

The pressure transducer ME 05 may only be used for the use stated by the manufacturer in the data sheet or the operating manual.

It is designed for measuring the process variable 'pressure'.

The measuring ranges are scaled from 1.0 bar to 250 bar based on DIN EN 837.

The construction ensures that an overload relief of 1.5 times the pressure of the respective measuring range pressure is reached.

Gases, vapours and fluids can be measured. Parts that come into contact with the measuring media are made of the corrosion-proof chrome-nickel steel 1.4571 and 1.4404.

3 Description of the product and functional description

3.1 Assembly

The pressure transducer ME05 has a modular design. It basically comprises the measuring system and the electronics which consist of the power supply unit, amplifier and control board.

The measuring system and electronics are installed in the same housing. The housing is divided with a separator. The electronics control panel can be accessed by unscrewing the lid of the housing.

3.2 Measuring system

The main elements of the measuring system are the Bourdon tube, the process connection and the inductive pickup system. The Bourdon tube is welded into the process connection. The coil system of the inductive pickup is flanged to the side of the process connection in a clamping block. The transfer core is attached to the free end of the Bourdon tube. It dips into the coil element of the inductive pickup system. Together, the coils wound on the coil elements form a differential transformer.

The structure of the measuring system is the same for all measuring ranges. Depending on the measuring range, the material thickness and the winding shape of the Bourdon tube vary. The measuring system works dry, without filling fluid.

Optimum overload protection is achieved thanks to the constructive design of the Bourdon tube and the additional supports in the housing. If the pressure exceeds the respective measuring range, the Bourdon tube leans against the supports on the housing side to protect itself from damage.

Fig. 1 Pressure measuring system

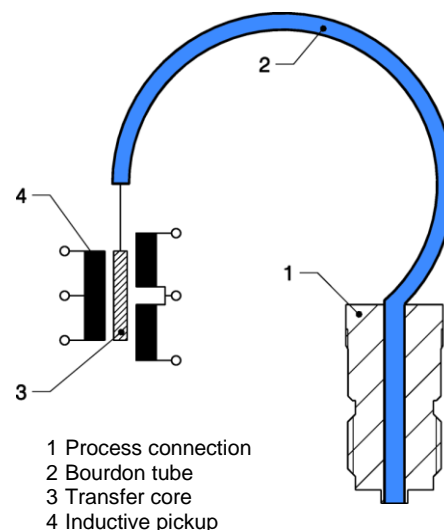

3.3 Function

Over-pressure in the Bourdon tube causes a proportional deflection that is also executed by the transfer core attached to the end of the Bourdon tube.

This pressure-proportional movement creates a change of voltage in the inductive pickup system. The downstream electronics convert the voltage change into a direct current signal.

3.4 Power supply board

The power supply board generates the internal voltages required to operate the main board or control board. A switching power supply generates three isolated DC voltages from the supply voltage (approx. +22V, approx. +9.5V and approx. -9.5V). The control electronics stabilise the output voltages and compensate the fluctuations of the incoming voltage.

3.5 Main board

The most important components on the main board are the oscillator, rectifier, amplifier and output stage for the 0/4-20mA current output. The oscillator activates the primary coil of the inductive pickup system with a fixed frequency AC current. A voltage that is proportional to the measuring pressure is induced in the secondary side of the displacement transducer. A rectifier converts this AC current into a DC measuring signal that is sent to the characteristic curve correction on the control board. An optional root extraction component influences the characteristic line for flow-rate measurements. An output stage generates a current output signal (0-20mA or 4-20mA, depending on the option).

3.6 Operation board

All setting devices that the user requires to operate the transmitter are located together on the control board. The measuring start (0-100% of the measuring range) and the measuring span (splitting up to 5:1) of the characteristic curve can be influenced via the zero-point and span correction. A switch inverts the signal for a falling characteristic curve. Optionally, an attenuation module can be configured. A test socket allows the signal to be controlled without interrupting the output circuit.

Fig. 2 Block diagram of the electronics

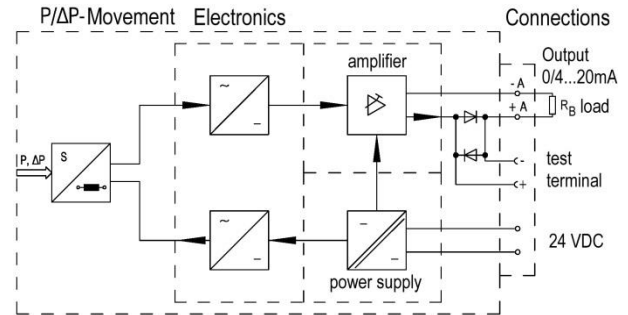

4 Mounting and Installation

4.1 Generalities

Before mounting the pressure transducer, check whether the device model satisfies the measuring and safety requirements of the measuring point, e.g. in terms of materials, measuring range, temperature and operating voltage. Also, the relevant guidelines, ordinances, standards and the accident prevention regulations need to be observed.

General information about the correct assembly of pressure transducers and measuring lines is provided below. The measuring precision largely depends on the correct installation of the pressure transducer and the associated measuring lines. The measuring setup should be protected as far as possible from critical ambient conditions, such as large temperature changes, vibration and shock. If severe ambient conditions cannot be avoided for constructional, measuring-specific or any other reasons, this can affect the measuring quality! (see Chapter 11 "Technical data").

If there are pressure sensors with capillary tubes attached to the pressure transducer, the additional operating manual needs to be observed!

4.2 Pressure transducer

The pressure transducer can be mounted directly above the process connection - threaded bore EN 837...G1/2 A or it can be mounted using the assembly accessories. Optionally, there is an attachment bracket for wall and pipe assembly (2" pipe) or a wall bracket with connecting parts available as accessories.

To minimise position-related influences on the measuring system, the pressure transducer should be mounted vertically gauged by eye.

Fig. 3 Direct assembly

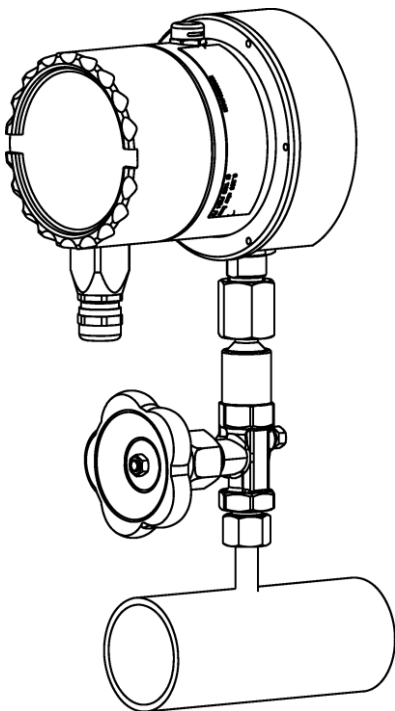

Fig. 4 Assembly with wall bracket (accessories)

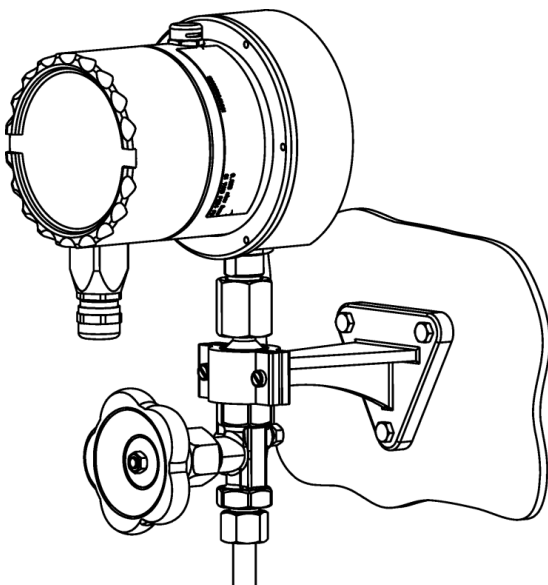
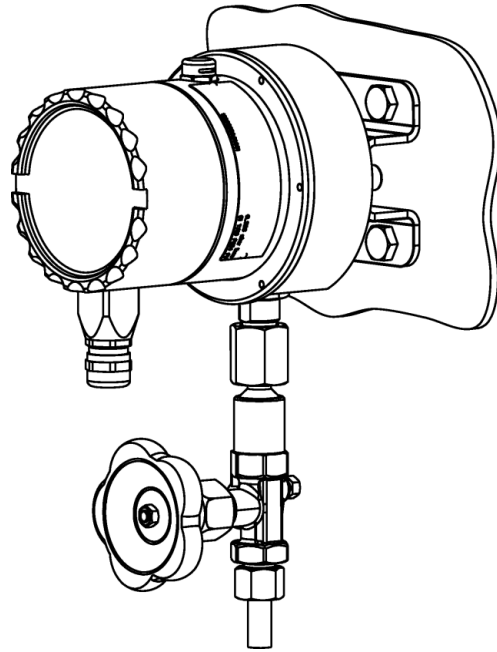

Fig. 5 Wall mounting



4.3 Measuring lines

The following points should be observed to ensure correct installation:

- Install the measuring line along the shortest possible path and avoid severe bending.
- Lay the measuring line so that no deposits can collect inside and the gas bubbles/condensate flows back into the process (increase >7.5 %).
- The measuring line should be blown out or rinsed out with compressed air or even better with the measuring media before it is connected to the pressure transducer.
- Completely vent the measuring line with fluid measuring media.
- When laying the measuring line outdoors, take suitable frost protection measures.
- The measuring line must be laid to ensure that there is no mechanical tension on the pressure transducer.

4.4 Structure of the pressure measurement process

4.4.1 Measuring steam

The pressure transducer should be mounted as shown in Fig. 6 so that the measuring line remains filled with condensation and no steam penetrates the measuring system.

Fig. 6

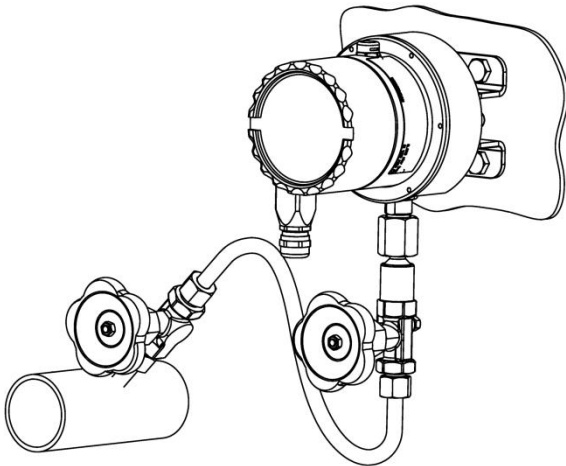

4.4.2 Liquids

If possible, the pressure transducer should be mounted below, but at least at the same height, as the removal pipes. If mounted below the removal pipe, the height difference (H) between the pipe and the pressure transducer displaces the measuring start.

Fig. 7

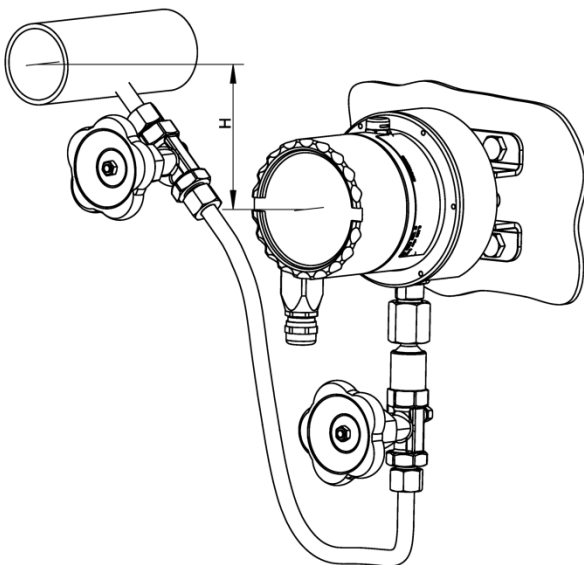

4.4.3 Gas measurement

The pressure transducer should be mounted above the measuring point if possible so that the condensation can flow into the process line.

Fig. 8

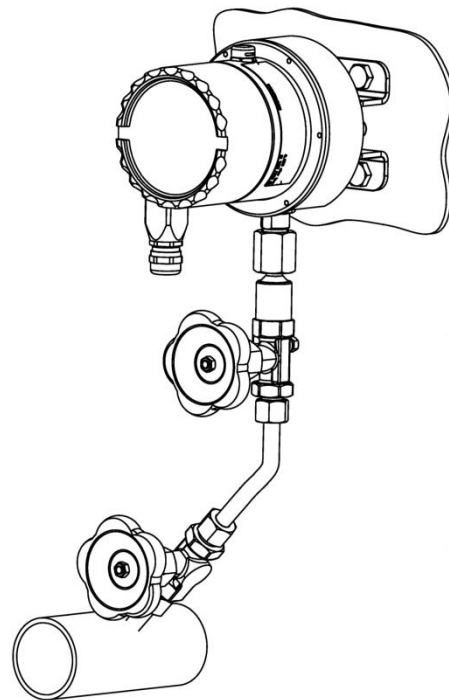

4.5 Electrical connection

Observe the corresponding regulations during the electrical installation!

Steps need to be taken to check whether the current operating voltage complies with the voltage stated on the type plate.

The energy supply and the output signal are electrically separated. The output signal is short-circuit-proof, no-load-proof and potential-free.

The pressure transducer is electrically connected via a plug with a cable gland PG11.

Ensure that the transducer is functionally earthed correctly. The connection on the outside of the housing must be used for this.

Power supply:

Auxiliary energy U_B 24V DC +50% / - 25%

For plug version (general):

The unit is connected to the power supply on the outside of the housing via the plug. The device socket for the cable connection is enclosed in a dismantled form as an accessory for the pressure transducer.

Fig. 9 Assembly of the device socket

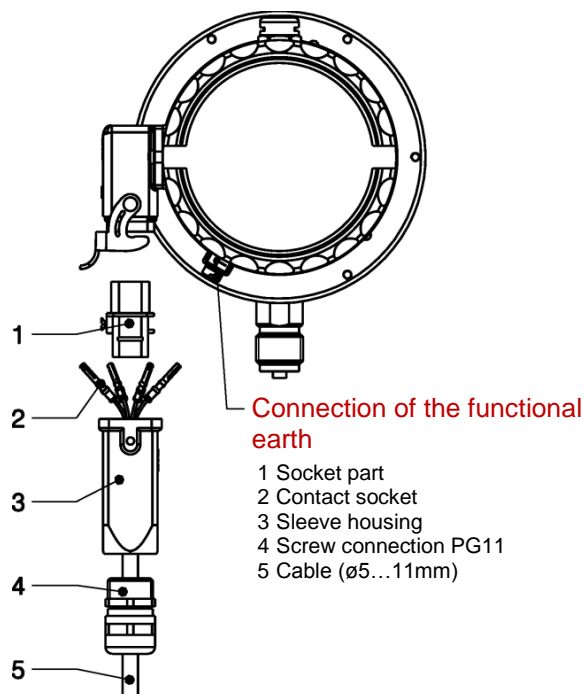

Assembly:

The contact sockets (2) are crimped or soldered on the 1.5...2 cm stripped sections or on the approx. 8 mm stripped cable ends and are then fed into the socket part (1) from behind. The sleeve housing (3) and screw connection PG11 (4) need to be pushed onto the cable in the given order before mounting.

Caution:

Before the sockets are completely inserted into the socket part, the connection point must be checked again. Incorrectly inserted sockets can only be removed again using an extraction tool (Harting order no.: 0999 000 0052).

Fig. 10 Socket part (view of the sockets)

HAN 7 D

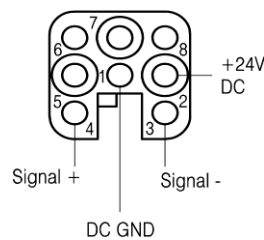

The planned crimp connection for the cable cross-section lies between 0.7mm²...1.0 mm².

5 Commissioning

5.1 Generalities

Once the pressure transducer has been installed, it is commissioned by switching on the operating voltage.

- Check the following before switching on the operating voltage:
 - Process connections
 - Electrical connection
 - That the measuring lines and measuring chambers of the pressure transducer are completely filled with the measuring media.
- After switching on the operating voltage, carry out a zero-point control ($p = 0$):
 - Before the zero-point control, the pressure transducer must have reached its operating temperature (approx. 5 min. operating duration, if the pressure transducer has already adopted the ambient temperature).
 - Using the 'ZERO' potentiometer, it is possible to set the starting point of the output signal to 0 or it can be corrected for 4 mA at $p = 0$. If the pressure transducer is designed for the \pm measuring range, the respective current value at $p = 0$ must be calculated.
- This is followed by the commissioning phase. Here, the shut-off valves and fittings should be activated in reverse order (basic setting: all valves closed):
 - Open the extraction shutoff valve - if there is one.
 - Open the shutoff valve.

Decommissioning is carried out in reverse order.

5.2 Operating elements

Fig. 11

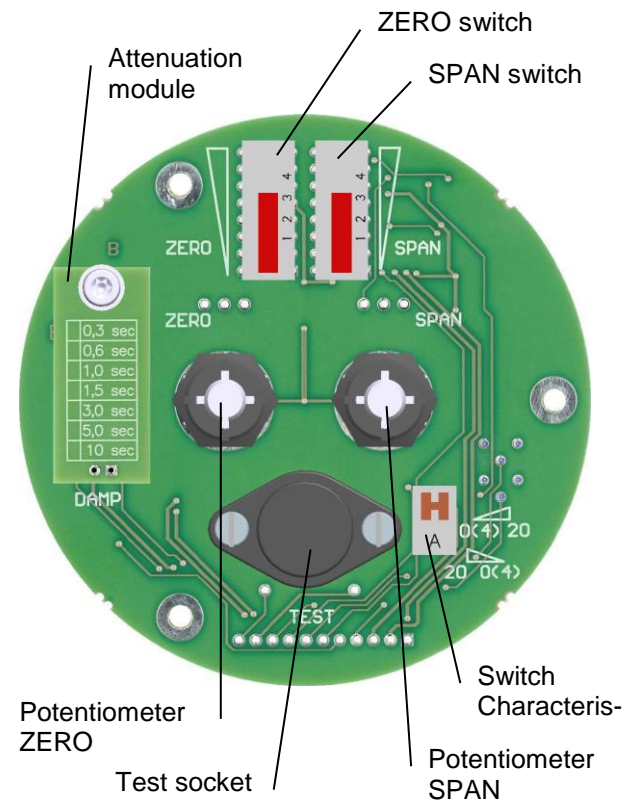

5.3 Attenuation

An unstable output signal from the pressure transducer caused by the process can be electrically smoothed using a damping element.

The attenuation elements are available in 7 different time constants: 0.3s; 0.6s; 1.0s; 1.5s; 3.0s; 5.0s; 10.0s

An attenuation element is easy to retrofit. However, it should be noted that if it is installed during operation, the output signal will drop to approx. 0/4mA, after which it will rise again to the measuring value in line with the time constants.

The installation site is easily accessible once the screw-on lid has been removed.

5.4 Checking calibration

The pressure transducer must be calibrated by the manufacturer in line with the details on the order. The set values for the measuring start and end are stated on the type plate (see Fig. 12).

Fig. 12 type plate (example)

Pressure transducer	FISCHER MESS- UND REGELTECHNIK D-32107 Bad Salzufflen	
Type:	ME05070082P9W000	
Auxiliary enrgy:	24V DC	
Output:	4-20 mA / 4-wire	
Measuring range:	0...10 bar / PN 250 bar	Cal.: 0...10 bar
Type-No.:	XXXXXXX.XX.XXX	AKZ: 02 YA10 P54 F11

The measuring start and measuring end can be calibrated afterwards independently of each other. The measuring range end value is calibrated when the measuring span is configured.

In order to check the pressure transducer, the measuring start and end are defined as pressure on the measuring system. If the measuring system is installed with test connections via shutoff valves, these are used for pressurization (otherwise the pressure transmitter needs to be disconnected from the measuring point). The operating sequence is important:

- Close the extraction shutoff valve
- Close the shutoff valve.

Relieve system pressure on the pressure transducer via the testing connection

- Connect the test sensor to the testing connection
- Check

Pressure calibrators with configurable pressure and comparison displays can be used as test sensors. When connecting avoid residual fluids (for gaseous test media) or air bubbles (for fluid test media) in the connection lines because this can cause errors in the test.

The accuracy of the measuring devices should be much higher than that of the pressure transducer.

The time behaviour needs to be taken into account when the attenuation module is installed.

After testing, the pressure transducer must be commissioned as described in section 5.1.

The output signal can be measured on the test socket 'TEST' (use the plug defined in DIN 41529). The housing lid needs to be unscrewed.

Drop of voltage in the current measuring device < 300mV at 20mA.

Fig. 13 Calibration of the measuring start and end

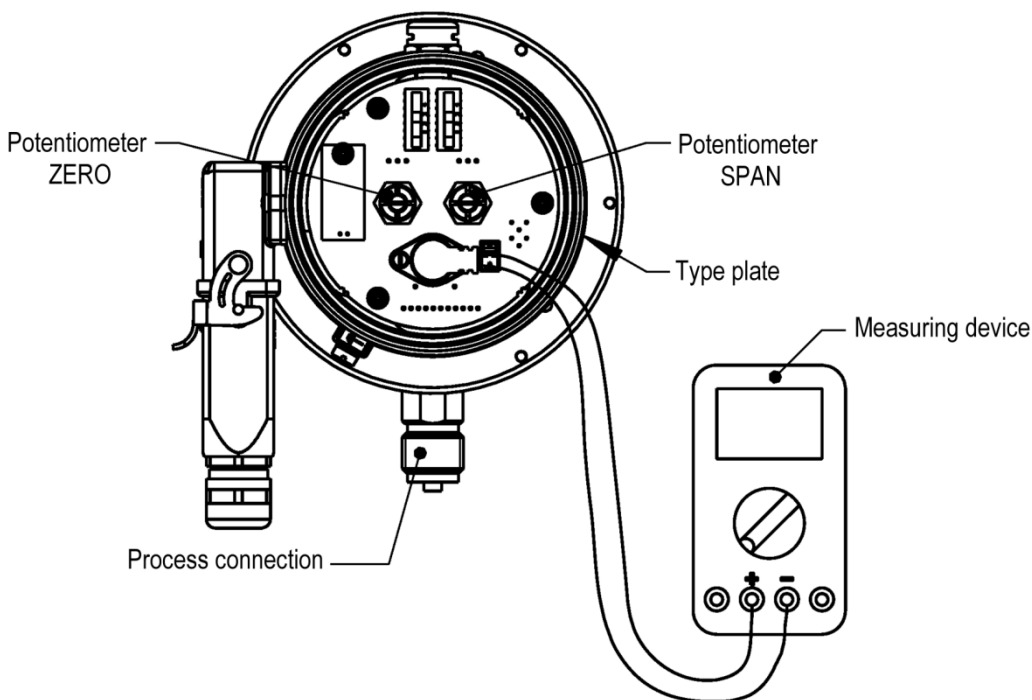

5.4.1 Check measuring start (0 or 4 mA)

At the corresponding pressure level as stated on the type plate, the current measuring unit must show 0 or 4mA on the analogue output or testing socket.

Correct any deviations using the potentiometer ZERO and a screwdriver. The ZERO switch defines the setting range of the potentiometer (see 5.6.1).

Fig. 14

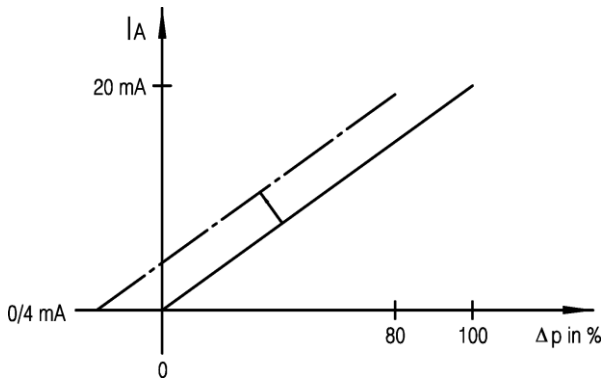

5.4.2 Check measuring end (20mA)

At the corresponding pressure level as stated on the type plate, the current measuring unit must show 20mA on the analogue output or testing socket.

Correct any deviations using the potentiometer SPAN and a screwdriver. The SPAN switch defines the setting range of the potentiometer (see 5.6.2).

Fig. 15

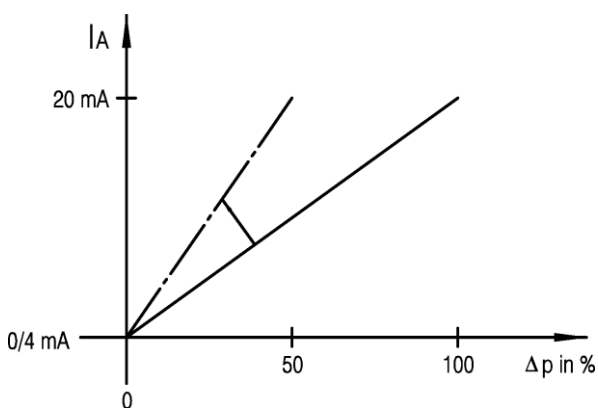

5.5 Function control and troubleshooting

If the pressure transducer does not work properly, check the following:

- does the measuring signal lie within the measuring span
- are all electrical connections connected
- is the required auxiliary energy available
- is the signal circuit closed
- is the resistance within the permissible limit

5.6 Changes to the device settings

The pressure transducer is configured in the factory to the values stated on the type plate. If the pressure transducer needs to be set to another measuring span or measuring start, the preliminary or fine adjustment need to be changed for the measuring start and measuring span.

The configured values must be recorded on the type plate!

The measuring span that can be configured depends on the measuring range of the respective measuring system. To this end, the type key on the type plate (Fig. 12) needs to be compared to the Technical data (see section 11).

Only measuring spans that lie within the measuring range are permitted.

5.6.1 Measuring start

The ZERO switch and the potentiometer ZERO allow the measuring start to be calibrated to approx. -50% to approx. 100% of the measuring range.

Table 1 Measuring start setting range

ZERO switch	Setting range potentiometer ZERO
1	approx. -50% ... approx. 3.5%
2	approx. -8.5% ... approx. 26.5%
3	approx. 15.5% ... approx. 74.5%
4	approx. 60.5% ... approx. 100%

On delivery, the ZERO switch is in position 2.

The required range must be set initially with the ZERO switch.

Then the potentiometer ZERO is used to set the measuring start precisely. At the corresponding pressure level, the current measuring unit must show 0 or 4mA on the analogue output or testing socket.

5.6.2 Measuring span

The SPAN switch and the potentiometer SPAN allow the measuring span to be calibrated from approx. 20% to approx. 110% of the measuring range.

Table 2 Setting range of measuring span

SPAN switch	Setting range potentiometer SPAN
1	approx. 110% ... approx. 83%
2	approx. 100% ... approx. 40%
3	approx. 50% ... approx. 29%
4	approx. 32% ... approx. 17%

On delivery, the SPAN switch is in position 1.

The required range must be set initially with the SPAN switch.

Then the potentiometer SPAN is used to set the measuring end precisely. At the corresponding pressure level, the current measuring unit must show 20mA on the analogue output or testing socket.

Then the measuring start needs to be checked.

5.6.3 Characteristic curve



Setting the characteristic curve is not a normal application case in nuclear technology

The characteristic curve switch swaps between the rising and falling characteristic curve.

In the "0 (4) - 20" position, the pressure transducer supplies 20mA at the start of the measuring process and 0 or 4mA at the end of the measuring process.

In the "20 - 0 (4)" position, the pressure transducer supplies 20mA at the start of the measuring process and 0 or 4mA at the end of the measuring process.

After switching the characteristic curve, the calibration of the measuring start and end must be checked.

When the characteristic curve drops, the analogue output at the start of the measuring process must be calibrated with the potentiometer ZERO to 20mA. At the end of the measuring process, the analogue output must be set to 0 or 4mA with the potentiometer SPAN.

6 Maintenance

The instrument is maintenance-free.

It suffices if the output signal is checked at certain intervals – depending on the operating conditions – in accordance with section 5.4 Checking the calibration.

It is recommended replacing the pressure equalisation element at regular intervals. Depending on the level of soiling in the environment, we recommend an interval of three to five years.

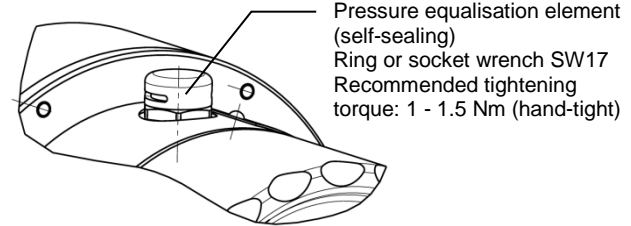

7 Transport

The measuring device must be protected against impacts. It may only be transported in packaging specifically intended for transport.

8 Service

All defective or faulty devices should be sent directly to our repair department. Please coordinate all shipments with our sales department.



Process media residues in and on dismantled devices can be a hazard to people, animals and the environment. Take adequate preventive measures. If required, the devices must be cleaned thoroughly.

9 Accessories

Art. No.	Designation
09007277	Pressure equalisation element stainless steel M12x1.5

10 Disposal

For the sake of the environment...



Please help to protect our environment and dispose of or recycle used instruments as stipulated by the applicable regulations.

11 Technical data

Measuring ranges	bar	bar	bar	bar	bar	bar	bar	bar	bar	bar	bar	bar	bar				
	0...1	0...1.6	0...2.5	0...4	0...6	0...10	0...16	0...25	0...40	0...60	0...100	0...160	0...250				

	General points
Measuring principle	Bourdon tube measuring element with an inductive pickup system (see function chart)
Measuring media	Gases, vapours, fluids
Overload limit	1.5 x upper range value (momentary)
Measuring ranges	0 ... 1.0 bar to 0 ... 250 bar (customer-specific measuring ranges are possible *)
Measuring span	Can be set steplessly from 20% ... 100% of the max. measuring range
Measuring start	Can be set steplessly from 0% to 100% of the measuring range when the characteristic curve falls (switchable) can be set steplessly from 100% to 0% of the measuring range
	Ambient conditions
Ambient temperature:	-10 °C ... +70 °C
Storage temperature	-25 °C ... +80 °C
Humidity	≤95% annual mean value, moisture condensation permissible
Electromagnetic compatibility	DIN EN 61000-6-2 (interference resistance in the industrial field) DIN EN 61000-6-4 (emitted interference in the industrial field)
	Electrical data
Technology	Analogue
Electrical connection type	4-conductor, electrically isolated
Auxiliary energy	24V DC +50 % / -25 % 5 W
Output signal	0/4 ... 20 mA
Test socket	Checking the output signal
Admissible resistance	0 ... 750 Ohm
Characteristic curve	Linear, rising or falling (switchable)
Rising time (damping module)	0.3; 0.6; 1.0; 1.5; 3; 5 and 10s (pluggable)

Technical data (cont'd)

<p>Device structure Housing (amplifier housing) Protection class as per EN 60 529/IEC 529 Assembly type Nominal position, installation position colour</p>	<p>Housing Compact design Copper-free aluminium (AlMgSiPb) IP65 Wall and pipe mounting, material 1.4301 (AISI 304) Vertical, amplifier in front position 2K-epoxy coloured paint RAL 5021 sliik-gloss</p>
<p>Measuring element Process connection</p>	<p>Materials that come into contact with the measuring media Bourdon tube chromium nickel steel 1.4404 (AISI 316L) Chromium nickel steel 1.4571 (AISI 316 Ti)</p>
<p>Device connection Process connection</p>	<p>Ports Plug / plug connection Harting HAN 7D G1/2" B outer thread vertical downwards, DIN EN 837</p>
<p>Differential pressure transducer Assembly parts</p>	<p>Weight ≤ 2.2 kg ≤ 0.6 kg (wall mount)</p>

Technical data (cont'd)

Error tolerances according to DIN EN 60770

	Characteristic curve conformity¹
	Linear characteristic curve
Measurement deviation (Non-linearity, hysteresis, non-repetitive)	≤ 0.75 %
Non-linearity/noncompliance	≤ 0.4 %
Hysteresis	≤ 0.4 %
Non-repetitive	≤ 0.3 %
	Temperature influence¹
on the zero-point	≤ 0.2 % / 10 K
on the measuring span	≤ 0.2 % / 10 K
	Impact of range overstepping by 50% of the measuring range on the zero-point in both directions¹
on the zero-point	≤ 0.2 %
on the measuring span	≤ 0.2 %
	Electrical influences
Power supply influence	≤ 0.01% / V
Output load influence	≤ 0.01 % / 100 Ohm
Output ripple	≤ 3 %
Grounding influence	≤ 0.1 %
Energy input	≤ 5 W
Insulation resistance	> 1 MΩ
Withstand voltage	≤ 500 V AC
	Jump response
Without attenuation module	Time constants (0...63 %): < 0.4 s Rising time (0...90 %): < 0.6 s
	Other influences¹
Long-term stability (long-term drift)	≤ 0.2% every six months
Behaviour in case of system-related pressure oscillations (at a max. amplitude of ±10 % FS and a frequency of 10 ... 80 Hz)	The constant component of the output signal is not impacted on impermissibly by the superimposed pressure oscillations.
	Position dependency for ±10⁻¹
All measuring ranges	< 0.15 %

¹ All deviations do not refer to the non-spread measuring range. These deviations increase proportionally to the set spread.

Technical data (cont'd)

for the scope, power station KTA 3505'

	Design 'K'
Product qualification	in compliance with KTA 3505
Area of application	Reactor protection system "KMV incident - ring room leak 1"
Safety-relevant classification	according to DIN IEC 61226 in category A
Manufacturer qualification	KTA 1401
Assembly type	Assembly in compliance with operating equipment installation plan
allowed deviation during mechanical load in compliance with KTA3505 Sec. 5.8	$\leq 3\%$ ² Test was carried out in compliance with the operating equipment installation plan ME05 (09.005.00.35146.3)
	Measurement deviation for KMV incident loss of coolant³
Behaviour in case of pressure, temperature and moisture stress in the transient range	$\leq 8\%$ ⁴
Behaviour in case of pressure, temperature and moisture stress in the stationary range	$\leq 5\%$ ⁵
Measuring deviation after pressure, temperature and moisture load	$\leq 2\%$
Behaviour in case of radiation load	$\leq 5\%$ ⁶

Unique allowed incident load

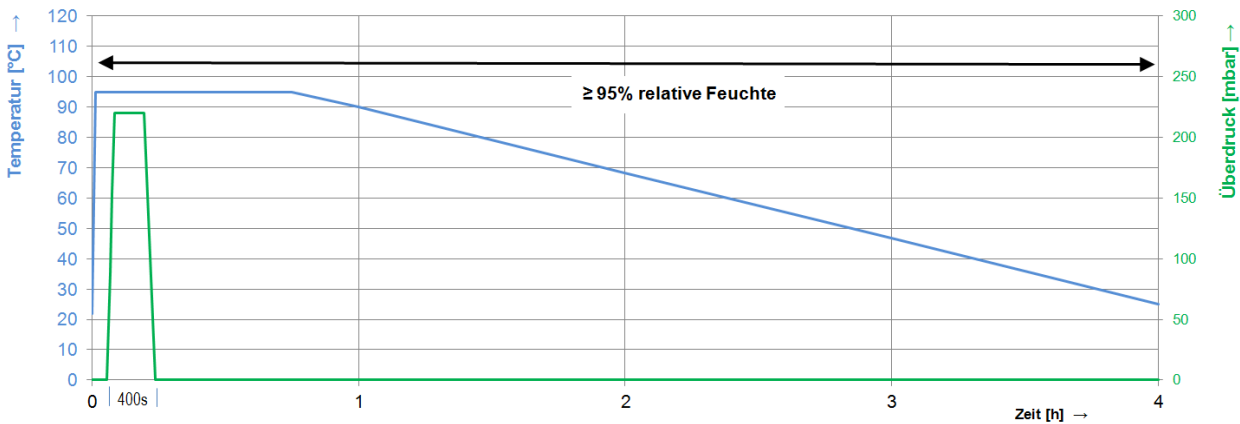

² Deviation after the load: see information under measuring deviation page 13

³ All deviations do not refer to the non-spread measuring range. These deviations increase proportionally to the set spread.

⁴ Maximum deviation in the transient range during fast temperature change like at the start of the incident load or under great ambient pressure changes through to pressure equalisation in the housing

⁵ Maximum deviation in the stationary range after the measuring system has stabilised during the incident load.

⁶ Behaviour in case of a dosing output $5\text{Gy/h} < \dot{D} \leq 25\text{Gy/h}$ up to a total dose of 1000 kGy.

12 Dimensional drawings (all dimensions in mm unless otherwise specified)

Process connection design below

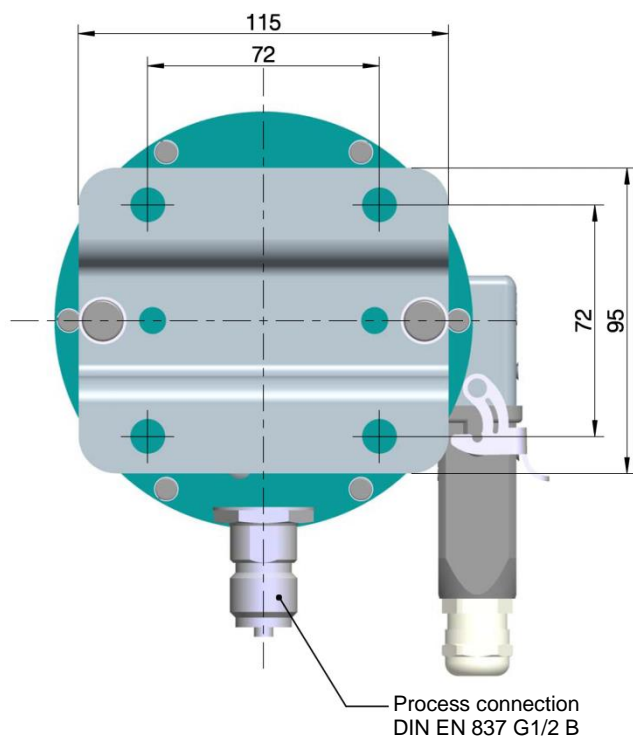
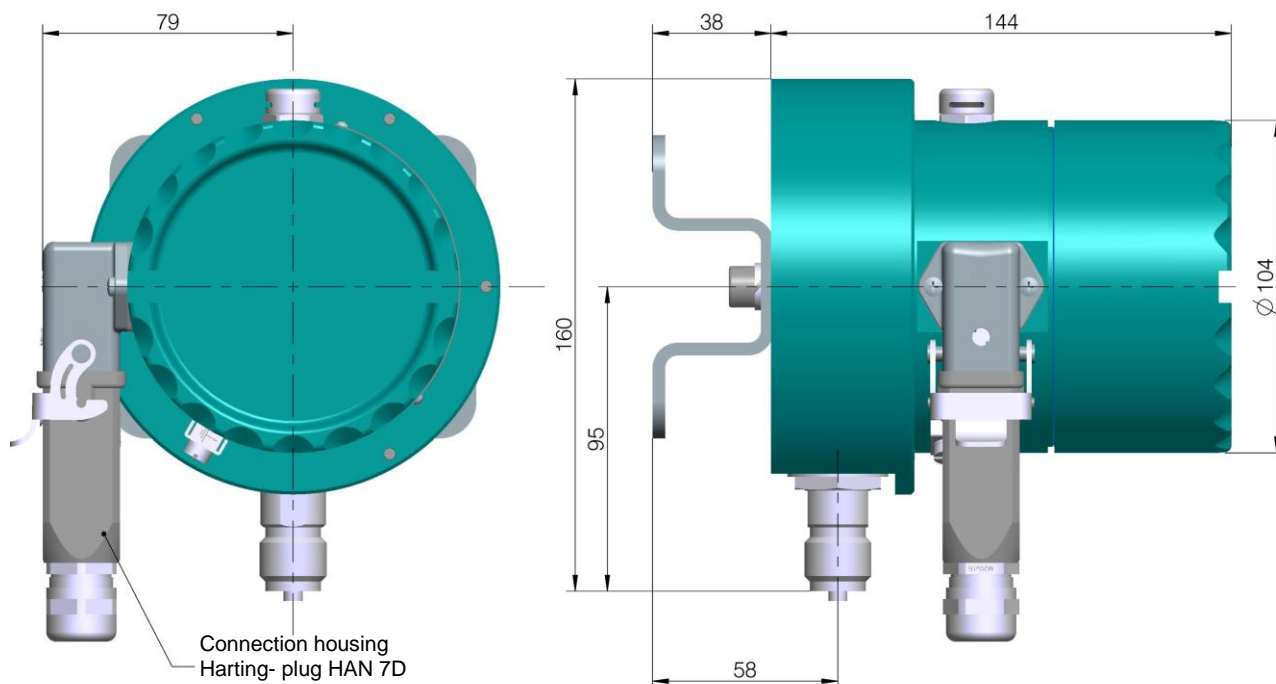

13 Order Codes

Pressure transducer

Type ME05

			0	8	7		9		0			U####
--	--	--	---	---	---	--	---	--	---	--	--	-------

Measurement range

- 0.....1 bar.....> 0 2
- 0...1.6 bar.....> 0 3
- 0...2.5 bar.....> 0 4
- 0.....4 bar.....> 0 5
- 0.....6 bar.....> 0 6
- 0.....10 bar.....> 0 7
- 0.....16 bar.....> 0 8
- 0.....25 bar.....> 0 9
- 0....40 bar.....> 1 0
- 0....60 bar.....> 1 1
- 0...100 bar.....> 1 2
- 0...160 bar.....> 1 3
- 0...250 bar.....> 1 4

Area of application

- Industry.....> 0
- Power station KTA 3505.....> K

Pressure connection

- Connection shanks with external thread G ½ B, 1.4571.....> 8 7

Electrical output signal

- 0–20 mA linear, 4-conductor.....> A
- 4–20 mA linear, 4-conductor.....> P

Operating voltage

- 24 V DC (18 - 36 V DC).....> 9

Assembly

- Direct assembly.....> 0
- Wall mounting.....> W

Electronic attenuation

- without.....0
- 0.3 s.....1
- 0.6 s.....2
- 1.0 s.....3
- 1.5 s.....4
- 3.0 s.....5
- 5.0 s.....6
- 10.0s.....7

AKZ (Please clearly state the system code in plain text on the order!)

- without system code.....> 0
- with system code on the type plate.....> 1

Special customer-specific measuring range:

When a customer-specific measuring range is ordered, the next largest standard measuring range is selected.

The customer-specific measuring range must be stated in plain text on the order.

The order code is supplemented with an attached code ex works to securely identify the device.

Example: ME05020087A9W000

U####



09005340 BA_EN_ME05 Rev.I 08/15