

# Instruction Manual

## MA12 || Pressure Gauge

### Table of Contents

1. Safety Instructions
2. Intended Applications
3. Product Description and Functions
4. Installation
5. Commissioning
6. Maintenance
7. Transport
8. Service
9. Accessories
10. Disposal
11. Specifications
12. Dimensions
13. Ordering Code



## 1. Safety Instructions

### 1.1. General



This manual contains detailed information about the product and instructions for its installation, operation and maintenance. Operators and other technical personnel responsible for the equipment must read this thoroughly before attempting to install or operate this equipment. A copy of this manual must always be kept accessible at the place of work for reference by concerned personnel.

Chapter 1 (sections 1.2 through 1.7) contains general as well as specific safety instructions. Chapters 2 through 10, covering topics ranging from intended purpose of the equipment to its final disposal, also include important points relating to safety. Overlooking or ignoring any of these safety points can endanger humans and animals, and possibly cause damage to other equipment.

### 1.2. Personnel Qualification

Personnel responsible for installation, operation, maintenance and inspection of this product must have the qualifications, training and experience necessary to carry out such work on this type of equipment.

### 1.3. Risks of Disregarding Safety Instructions

Disregarding safety instructions, use of this product for purposes for which it is not intended, and/or operation of this product outside the limits specified for any of its technical parameters, can result in harm to persons, the environment, or the plant on which it is installed. Fischer Mess- und Regeltechnik GmbH will not be responsible for consequences in such circumstances.



### 1.4. Safety Instructions for Operators

Safety instructions for the proper use of this product must be followed. This information must be available at all times to personnel responsible for installation, operation, maintenance and inspection of this product. Adequate steps must be taken to prevent the occurrence of hazardous conditions that can be caused by electric energy and the convertible energy of the process media. Such conditions can, for example, be the result of improper electrical or process connections. Detailed information is available in relevant published norms (DIN EN, UVW in Germany; and equivalents in other countries), industrial standards such as DVWG, Ex-, GL-, VDE guidelines, as well as regulations of the local authorities (e.g., EVUs in Germany).

### 1.5. Modifications Forbidden

Modification or other technical alteration of the product is not permissible. This also applies to the use of unauthorized spare parts for repair / maintenance of the product. Any modifications to this product, if and as necessary, should be done only by Fischer Mess- und Regeltechnik GmbH.

### 1.6. Operational Restrictions

The operational reliability of the product is guaranteed only when used for intended purposes. The product must be selected and configured for use specifically with defined process media. The limiting values of operating parameters, as given in the product specification sheet, must never be crossed.

### 1.7. Safety Considerations during Installation and Maintenance

The safety instructions given in this manual, existing national regulations relating to accident prevention and the internal safety rules and procedures of the user organization regarding safety during installation, operation and servicing must all be followed meticulously.

It is the responsibility of the users to ensure that only suitably qualified and experienced technical personnel are used for installation, operation and servicing of this equipment.

## 2. Intended Applications

Pressure gauge, especially suited for heavy measuring conditions, e.g. in case of pressure shocks, vibrations or high demands on breaking capacity. The overpressure safe measuring system guarantees high operation safety. The product must be used only for applications and under conditions specified by Fischer Mess- und Regeltechnik GmbH.

Please confer with Fischer Mess- und Regeltechnik GmbH prior to using this instrument along with polluted or aggressive media. For use with this media it needs to be adapted in every part with direct contact to the media.

## 3. Product Description and Functions

### 3.1. Schematic Diagram

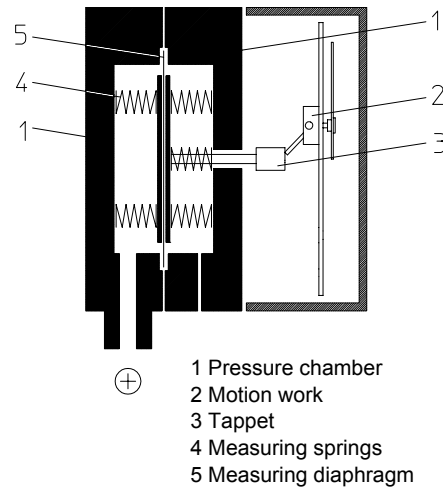

### 3.2. Principles of Operation

This pressure instrument is based on a rugged and uncomplicated diaphragm movement, suitable for overpressure and partial vacuum pressure measurements.

In non-operative state, forces of the springs on both sides of the diaphragm are balanced. Pressure or vacuum to be measured creates an unbalanced force of the springs until a new balance is reached. When subjected to excessive pressure, the diaphragm rests on metal supporting plates. A centre-mounted tappet transfers motion of the diaphragm system to indicator movement and operating elements of micro switches.

## 4. Installation

The instrument is intended for pipework mounting using a pressure connection shank per DIN EN 837 by default. Optional it can be wall-mounted by 3 fastening elements casted on housing. The instrument is factory calibrated while mounted upright, pressure port downward.

To ensure safety during installation and maintenance integrate adequate shut-off valves. By recommended accessories (see 9.) the instrument can be

- depressurized or shut down,
- cut off a plant to enable controlling or repairing,
- operational checked on site.

### 4.1. Process Connection

- Only qualified technicians authorized for this type of work should undertake installation.
- Only for intended mechanical process connection (for model information see ordering code on type plate of instrument).
- Ensure that process equipment and pressure lines are at atmospheric pressure before making pressure

connections.

- The instrument should be provided with suitable protection against pressure surges (e.g., snubber or pulsation damper).
- Ensure that the mechanical configuration and materials of construction of the instrument are compatible with the process media.
- Ensure that process pressure is always less than the specified safe pressure rating.

## 5. Commissioning

- All lines to the instrument must be correctly selected to meet operational requirements, and installed in a way that does not cause physical stress to the instrument.
- The pressure line must have a downward gradient throughout, from the pressure instrument to the process vessel / pipe. This is to prevent formation of air / gas pockets (for liquid applications) and liquid plugs (for air / gas applications). If this continuous downward gradient cannot be provided for any reason, then suitable water and / or air separation devices must be inserted in the pressure line.
- The instrument and lines must be protected against frost when used with water.
- The pressure line must be kept as short as possible and must not have short bends to avoid measurement errors induced by pressure line delays.
- Carefully check the pressure-tightness of pressure connection before start-up.

### 5.1. Pressure Connection

Pressure connection must be installed in a way that does not cause physical stress to the instrument.

### 5.2. Shock Pressure Moderation

During pulsating pressure on the plant mechanical wear and disturbances in functional capability may occur. To avoid this we recommend installing absorbers into the pressure line.

### For Liquid Media

Adjustable attenuator valve **MZ41**

During operating condition adjust needle valve that way, that the indicator follows changes of pressure delayed.

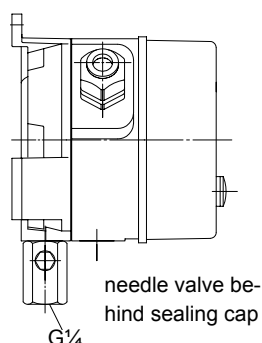

### For Gaseous Media

Capillary reactive coil **MZ400**

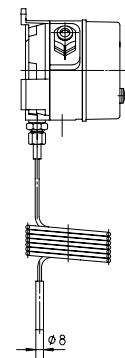

### 5.3. Adjustment of Zero Point

- Vent pressure lines to atmosphere.
- Remove cover.
- Set measuring indicator to zero by zero point adjustment screw (see 5.4.).
- Mount cover.

#### 5.3.1. Location of Zero Point Adjustment Screw

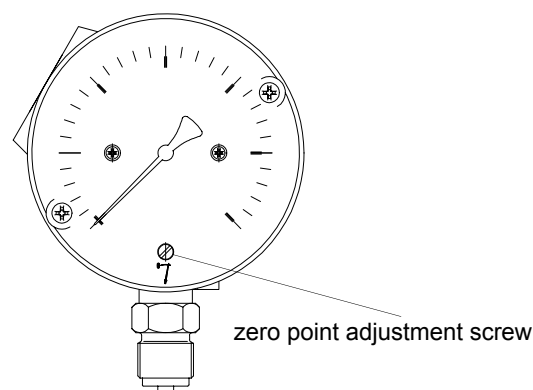

## 6. Maintenance

The instrument is inherently maintenance-free.

However, to ensure reliable operation and maximize the operating life of the instrument, it is recommended that the instrument, its external electrical and process connections and external connected devices be regularly inspected, e.g.:

- Check the display.
- Check all pressure connections for leak-tightness.

Inspection and test schedules depend on operating and site conditions. The operating manuals of other equipment to which the instrument is connected must be read thoroughly to ensure that all of them work correctly when connected together.

## 7. Transport

The product must be protected against shock and vibration during transport. It must therefore be properly packed, preferably in the original factory packaging, whenever it is to be transported.

## 8. Service

Any defective devices or devices with missing parts should be returned to Fischer Mess- und Regeltechnik GmbH. For quick service contact our service department.



Remaining medium in and on dismantled measuring instruments may cause danger to persons, environment and equipment. Take reasonable precautions! Clean the instrument thoroughly if necessary.

## 9. Accessories

- Accessory for manometer per datasheet MZ..., i.e. manometer valve
- Wall mounting kit acc. to DIN 16281
- Panel installation kit DZ11

## 10. Disposal



*Protect your environment!*

Use the product in accordance with relevant regulations. Please be aware of environmental consequences of disposal at the end of the product's life, and take care accordingly.

## 11. Specifications

Measuring range	0..400 mbar to 0..25 bar (see Ordering Code)
Nominal pressure rating	25 bar
Max. overpressure	overpressure safe up to nominal pressure rating for all ranges, vacuum safe
Perm. ambient temperature	-10..+70°C (max. 55°C for SEV-approbations)
Perm. medium temperature	70°C
Protection class	IP54 acc. to DIN EN 60529
Mounting position	vertical, pressure port downward (rear)
Accuracy	± 1.6 % FS
Zero adjustment	located in the dial
Pressure connection	G1/2 male thread acc. to DIN EN 837
<b>Measuring System</b>	
ranges ≤ 16 bar	diaphragm measuring system, diaphragm of reinforced elastomer
range 0-25 bar only	diaphragm measuring system, diaphragm of DURATHERM®
<b>Materials</b>	
Pressure chamber	aluminium GkAlSi10Mg, varnished black; aluminium GkAlSi10Mg with HART-COAT® surface protection chrome-nickel-steel 1.4305
Measuring diaphragm	diaphragm and gaskets of NBR or Viton®; diaphragm of DURATHERM® NiCrCo-alloy
Materials, media	stainless steel 1.4310, 1.4305
Materials, housing	macrolon
Weight	with aluminium pressure chamber 1.2 kg, with 1.4305 pressure chamber 3.5 kg
<b>Mounting / Installation</b>	
Pipe mounting	male thread acc. to DIN EN 837; bottom or rear pressure connection
Wall mounting	3 fastening elements; bottom pressure connection
Panel mounting	with front ring 132 mm Ø; bottom or rear pressure connection (accessory DZ11)

**12. Dimensions** (all units in mm unless otherwise stated)

**MA12  
(standard)**

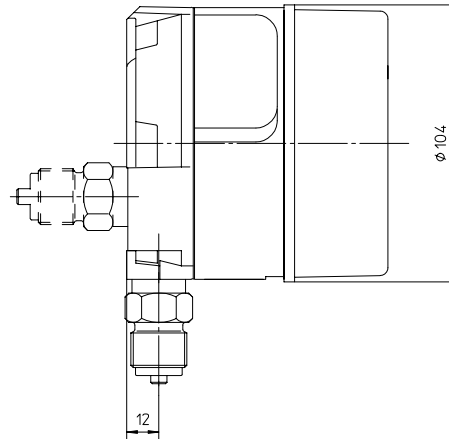
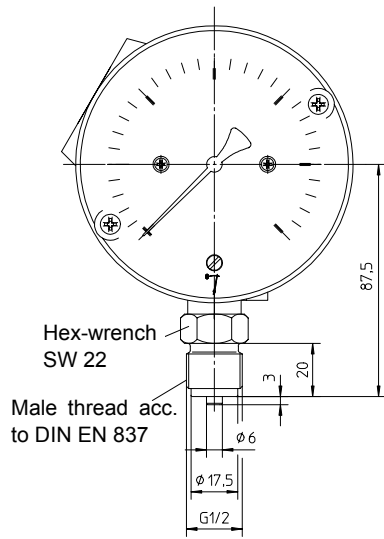

**MA12 Wallmounting**

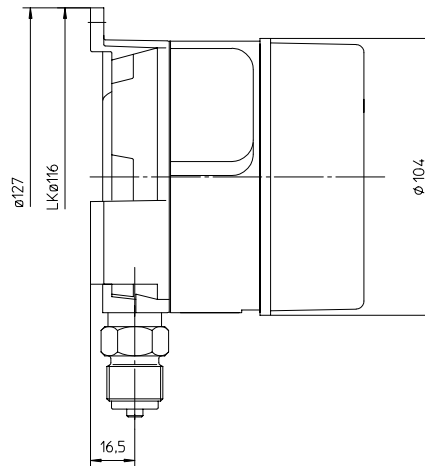
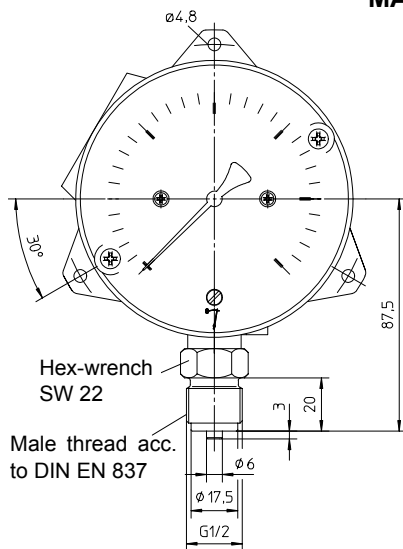

**MA12 Panel mounting**

