

Data sheet

DA01 VUW (ATEX)

Differential pressure measuring device
Pressure levels PN250/PN400

Models for use in
explosive areas

DA01 ... 0A
DA01 ... 1B
DA01 ... 1C

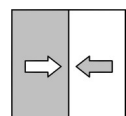

1 Product and functional description

1.1 Performance features

Typical applications

- Chemical, petrochemical industry
- Process technology
- Marine and offshore technology
- Power plant technology
- Mechanical and plant engineering

Important features

- Highly corrosion resistant
- CrNi-steel model
- Use with aggressive media
- Highly durable
- Variable connection technology
- With fluid filling as an option
- Optional additional equipment such as contact element

1.2 Equipment versions

The following illustrations depict typical combinations of the measuring cell, measured value display and contact elements. However, these can be freely combined according to the order code. Wherever this is not possible, this is clearly stated.

For instance, a small measuring cell with an NG160 display and a contact element is also available.

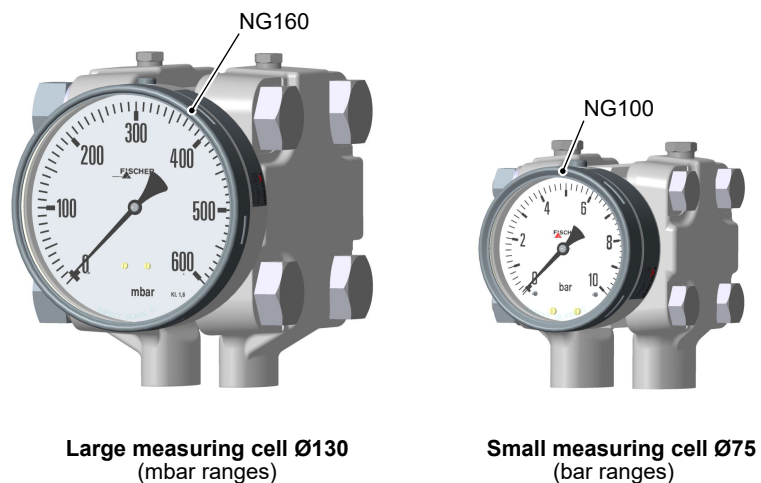

Fig. 1: Device overview

1.2.1 Process connection

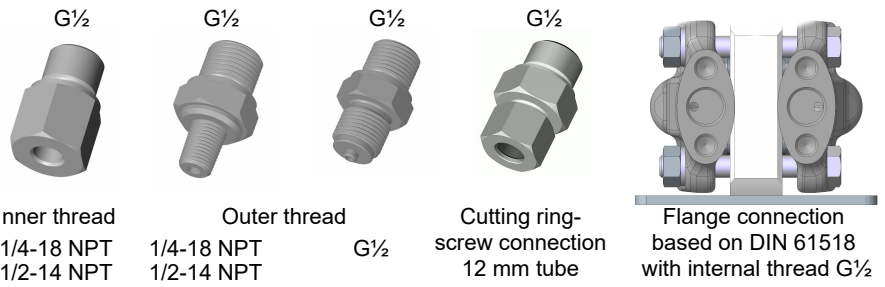

Fig. 2: Options for the process connection

1.2.2 Contact devices



Limit switch in accordance with data sheet KE##
for ATEX devices
<ul style="list-style-type: none"> • Snap-action contacts • Inductive contacts

Fig. 3: Contact devices

1.2.3 Special functions

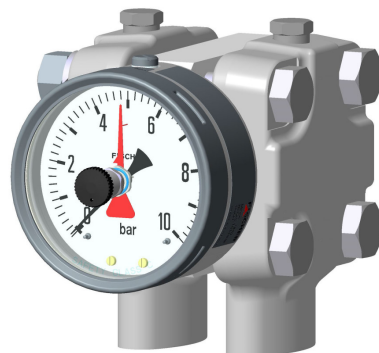

<ul style="list-style-type: none"> • Marker needle • Trailing needle 	Fluid fillings <ul style="list-style-type: none"> • Unit without contacts <i>glycerine, silicon oil</i>
----------------------------------------------------------------------------------------------	-----------------------------------------------------------------------------------------------------------------------------------

Fig. 4: Special functions

1.2.4 Assembly

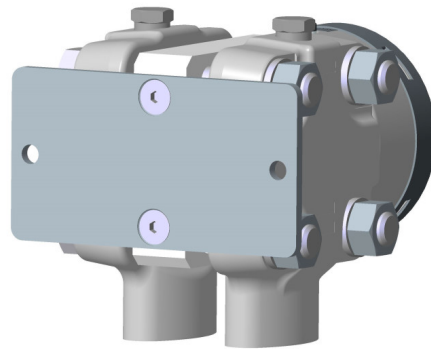

Wall mounting

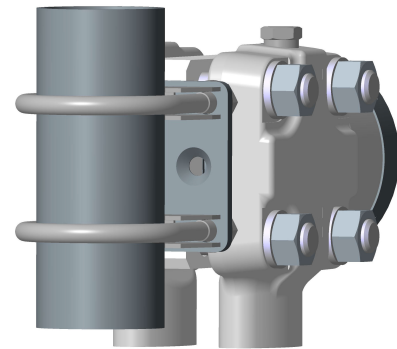

Pipe mounting

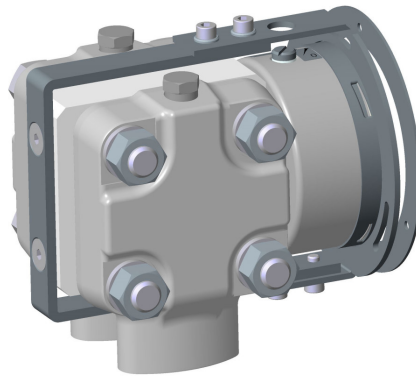

Panel mounting set type 1
with panel mounting set



Panel mounting set type 2
with front ring

Fig. 5: Assembly

The panel installation fittings can only be used in devices with a small measuring cell ($\varnothing 75$) and a display in the NG100 bayonet ring casing.



WARNING

Panel mounting set

Due to the heavy weight, the operator needs to install a support construction for installation of the front panel.

1.2.5 Equipment features (overview)

In the following, the equipment options of the DA01 are shown depending on the measuring cell used and the pressure stage.

NOTICE! Only single contacts, no changeover contacts possible.

Legend

- available
- on request

Small measuring cell Ø75

Measuring range	Measured value display Ø100	Low-action contacts			Snap-action contacts			Inductive contacts		Trailing needle	Marker needle	Remote seal	Pressure level
		1	2	3	1	2	3	1	2				
0 ... 0.6 bar	●				●			●		□	●	●	PN250/PN400
0 ... 1 bar	●				●			●		□	●	●	
0 ... 1.6 bar	●				●			●		□	●	●	
0 ... 2.5 bar	●				●			●		□	●	●	
0 ... 4.0 bar	●				●			●		□	●	●	
0 ... 6bar	●				●			●		□	●	●	
0 ... 10 bar	●				●			●		□	●	●	
0 ... 16 bar	●				●			●		□	●	●	
0 ... 25 bar	●				●			●		□	●	●	

Fig. 6: Small measuring cell Ø75 Measured value display Ø100

Measuring range	Measured value display Ø160	Low-action contacts			Snap-action contacts			Inductive contacts		Trailing needle	Marker needle	Remote seal	Pressure level
		1	2	3	1	2	3	1	2				
0 ... 0.6 bar	●				●			●		□	●	●	PN250/PN400
0 ... 1 bar	●				●			●		□	●	●	
0 ... 1.6 bar	●				●			●		□	●	●	
0 ... 2.5 bar	●				●			●		□	●	●	
0 ... 4.0 bar	●				●			●		□	●	●	
0 ... 6bar	●				●			●		□	●	●	
0 ... 10 bar	●				●			●		□	●	●	
0 ... 16 bar	●				●			●		□	●	●	
0 ... 25 bar	●				●			●		□	●	●	

Fig. 7: Small measuring cell Ø75 Measured value display Ø160

Large measuring cell Ø130

Measuring range	Measured value display Ø100	Low-action contacts			Snap-action contacts			Inductive contacts		Trailing needle	Marker needle	Remote seal	Pressure level
		1	2	3	1	2	3	1	2				
0 ... 40 mbar	●										●		PN250
0 ... 60 mbar	●										●		
0 ... 100 mbar	●									□	●		
0 ... 160 mbar	●				□			●		□	●	●	
0 ... 250 mbar	●				□			●		□	●	●	
0 ... 400 mbar	●				□			●		□	●	●	

Fig. 8: Große Messzelle Ø130 Messwertanzeige Ø100

Measuring range	Measured value display Ø160	Low-action contacts			Snap-action contacts			Inductive contacts		Trailing needle	Marker needle	Remote seal	Pressure level
		1	2	3	1	2	3	1	2				
0 ... 40 mbar	●										●		PN250
0 ... 60 mbar	●										●		
0 ... 100 mbar	●									□	●		
0 ... 160 mbar	●				□			●		□	●	●	
0 ... 250 mbar	●				□			●		□	●	●	
0 ... 400 mbar	●				□			●		□	●	●	

Fig. 9: Large measuring cell Ø130 Measured value display Ø160

1.3 Function diagram

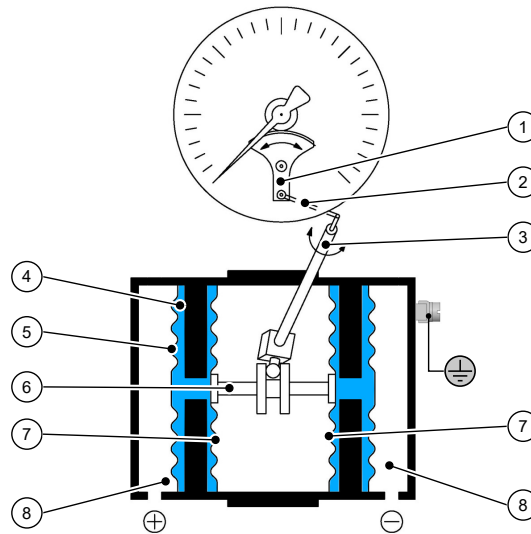

Fig. 10: Function diagram

1	Motion train	2	Transfer lever
3	Measuring shaft	4	Pressure transfer fluid
5	Separating membrane	6	Connecting rod
7	Measuring diaphragm	8	Pressure chamber

1.4 Design and mode of operation

The pressures in the pressure chambers that are to be compared are each exerted onto a measuring membrane that can be rigidly connected using a connection rod. To compensate the static pressure, the space between the separating and measuring membrane is filled with a pressure transfer fluid.

During pressure equalisation, the two measuring membranes are in an idle position. In case of pressure difference, the force acting on the membranes causes it to be moved towards the side of the lower pressure.

The connecting rod transfers the deflection of the measuring membranes onto the transfer lever mounted to the measuring shaft. Proportional to the current differential pressure, the measurement shaft makes a rotational movement that the indicator translates into a rotation angle between 0 and 270°.

In the case of one-sided pressure by the measuring system above and beyond the measuring range, the over-pressure guard will be activated which supports the overloaded membrane.

2 Technical Data

2.1 Allgemeines

EXECUTION	Nominal pressure	Measuring cell	Application information
DA01 V ...	PN250	Ø75	<p>Measuring ranges: 0...0.6 bar to 0...25 bar</p> <p>Remote seals: It is possible to attach remote seals for all measuring ranges. The remote seals need to be designed for the displacement volume, the length of the cable and the application temperature.</p>
DA01 U ...	PN400	Ø75	<p>Measuring ranges: 0...0.6 bar to 0...25 bar</p> <p>Remote seals: It is possible to attach remote seals for all measuring ranges. The remote seals need to be designed for the displacement volume, the length of the cable and the application temperature.</p>
DA01 W ...	PN250	Ø130	<p>Measuring ranges: 0...40 mbar to 0...400 bar</p> <p>Limitations: Drag indicator measuring ranges ≥ 60 mbar Contacts / Transmitter measuring ranges ≥ 100 mbar</p> <p>Remote seals: It is possible to attach remote seals for measuring ranges ≥ 160 mbar. The remote seals need to be designed for the displacement volume, the length of the cable and the application temperature.</p>

2.2 Input variables

Measuring variable

Differential pressure in gaseous and fluid aggressive media.

General

Rated pressure of the measuring system	Max. static operating pressure
Durability	One-sided over-pressure-proof up to the rated pressure of the measuring system resistance to under-pressure on the (+) and (-) side
Measurement accuracy	±1.6 % of the measuring range (without contacts)
Temperature sensor	0.3 % / 10 °C
Zero-point adjustment	±25 % of the measuring range

Measuring ranges

Small measuring cell Ø75

Measuring range	Device model		
	V	U	W
0 ... 0.6 bar	•	•	
0 ... 1 bar	•	•	
0 ... 1.6 bar	•	•	
0 ... 2.5bar	•	•	
0 ... 4.0 bar	•	•	
0 ... 6 bar	•	•	
0 ... 10 bar	•	•	
0 ... 16 bar	•	•	
0 ... 25 bar	•	•	

Large measuring cell Ø130

Measuring range	Device model		
	V	U	W
0 ... 40 mbar			•
0 ... 60 mbar			•
0 ... 100 mbar			•
0 ... 160 mbar			•
0 ... 250 mbar			•
0 ... 400 mbar			•

2.3 Operating conditions

Permissible ambient temperature	-20 ... +60 °C
Admissible storage temperature	-40 ... +80 °C
Admissible media temperature	< 85 °C
Type of protection:	IP 65 acc. to EN 60529

2.4 Construction design

Materials

Measured value display	Material	Material no.	
		EU	AISI
Bayonet ring housing NG100, NG160	CrNi steel	1.4301	304
Process connection (all models)	CrNi steel	1.4404	316L
Intermediate plate	AlMgSiPb	HARD-COAT®	
Seals (O-rings)	FKM		
Motion train	CrNi steel		
Dial face and needle	Aluminium, painted, printed		
Inspection disk	Safety laminated glass		

MB = Measurement range

Materials (media-contacting)

Design of the measuring system (R)	Material	Material no.	
		EU	AISI
Pressure caps	CrNi steel	1.4404	316L
Separation membranes	CrNi steel	1.4571	361Ti

Design of the measuring system (G)	Material	Material no.	
		EU	AISI
Pressure caps	CrNi steel	1.4404	316L
Separation membranes	Hastelloy® C276		

Process connection	Material	Material no.	
		EU	AISI
Connecting piece and port	CrNi steel	1.4404	316L
Cutting ring screw connections	CrNi steel	1.4571	

Assembly

Wall mounting	Flanged assembly plate
Pipe mounting	Flanged assembly plate and attachment bracket
Panel mounting set type 1	Panel installation fittings for units with a small measuring cell (Ø75) and NG100 bayonet ring casing.
Panel mounting set type 2	Front ring and support construction

2.4.1 Additional Attachments

2.4.1.1 Contact elements

Limit signal transmitters (contacts) can be fitted into a housing augmented by a corresponding bayonet ring connector.

A certain minimum pressure level is required to operate this kind of contact element, which is why there is a lower limit for the mbar measuring ranges. This limit depends on the model type and is stated in the section 'General'.

CAUTION! By driving and switching the contacts, the measuring deviation increases to a total of $\pm 2.5\%$ of the measuring range.

For more information and the order key, please refer to the data sheet:

- for limit switch in data sheet KE

2.4.1.2 Liquid filling

NOTICE! Only devices without contact device

Under difficult operating conditions such as vibrations, extreme pressure fluctuations or to prevent condensation in open-air installations, the housing can be filled with the following liquids:

- Glycerine
- Silicon oil

2.4.1.3 Marker needle

A settable red marker can be attached to the scale to clearly show a certain pressure (limit value).

2.4.1.4 Trailing needle

The trailing needle is 'dragged' with the measured value indicator. As there is no fixed connection between the two needles, one-off maximum values are stored. The trailing needle can be reset using an adjusting dial in the window. Trailing needles cannot be used in conjunction with contacts. A certain minimum pressure level is required to move the drag indicator, which is why there is a lower limit for the mbar measuring ranges. This limit depends on the model type and is stated in the section 'General'.

2.4.1.5 Shut-off fitting

3-spindle valve block PN 100, DN 5, can be directly flanged

- Type DZ3600SV2700
- Material 1.4571
- Functions: Shut-off, pressure compensation

2.4.2 Electrical connection

In the case of devices with auxiliary electronic equipment, the connection is realised using a cable socket attached to the side and/or with a Han 7D connector on the power plant models. The pin assignment depends on the version ordered and can be found in the KE data sheet.

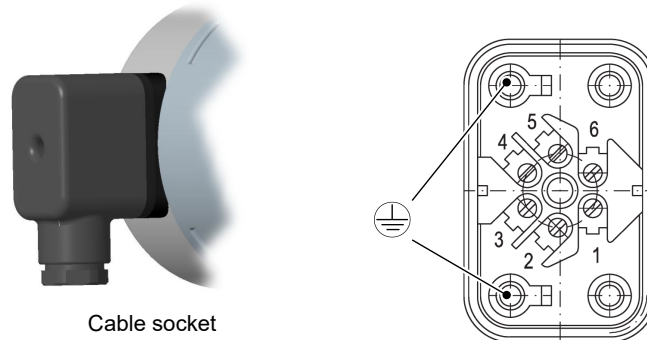

Cable socket

Fig. 11: Cable socket

Cable socket

Number of screw terminals	6 + 2PE
Rated current	See data sheet KE
Rated voltage	250 V
Conductor cross-section	up to 1.5 mm ² with wire protection
Cable gland	M20 x 1.5
Terminal range	7 ... 13 mm
Tightening torque	3 Nm
Key width	21
Protection class acc. to IEC 529	IP65 (when screwed in)

2.4.3 Dimensional drawings

All dimensions in mm unless otherwise stated

Small measuring system (Ø75)

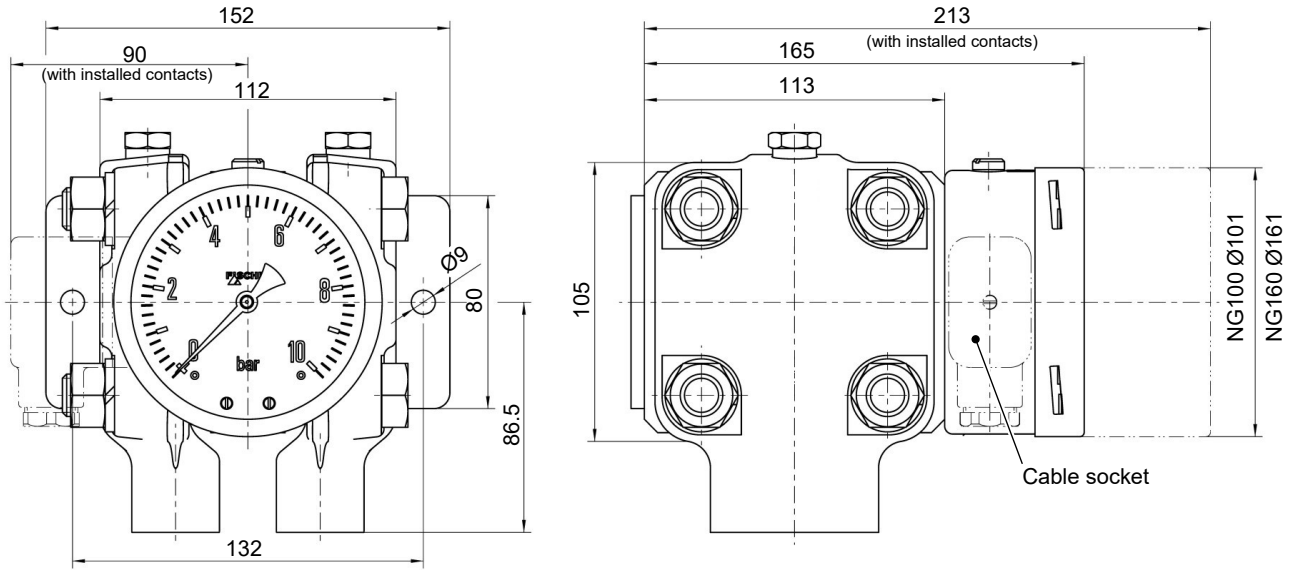

Flange based on DIN EN 61518

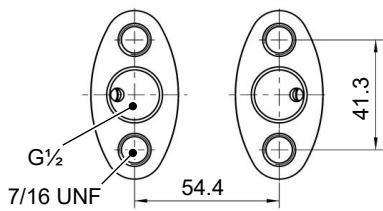

Wall mounting plate

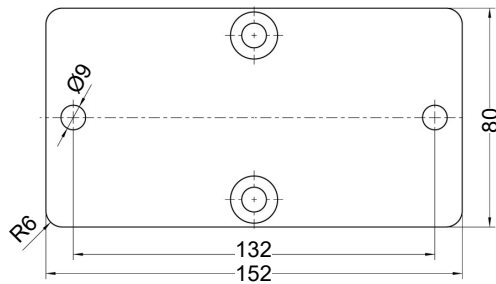

Fig. 12: Dimensional drawing (Small measuring system Ø75)

2" pipe mounting (possible for all models)

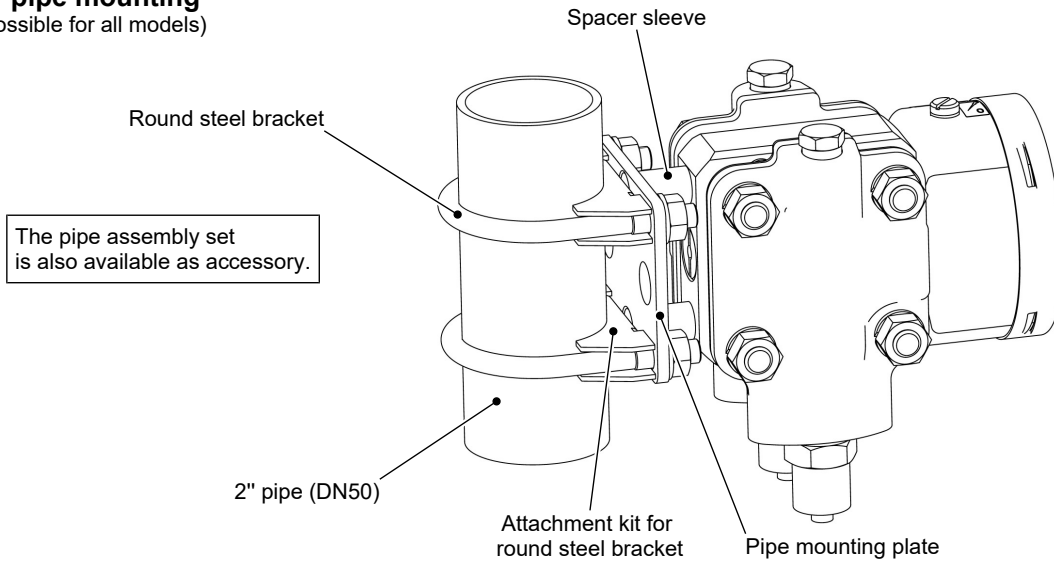
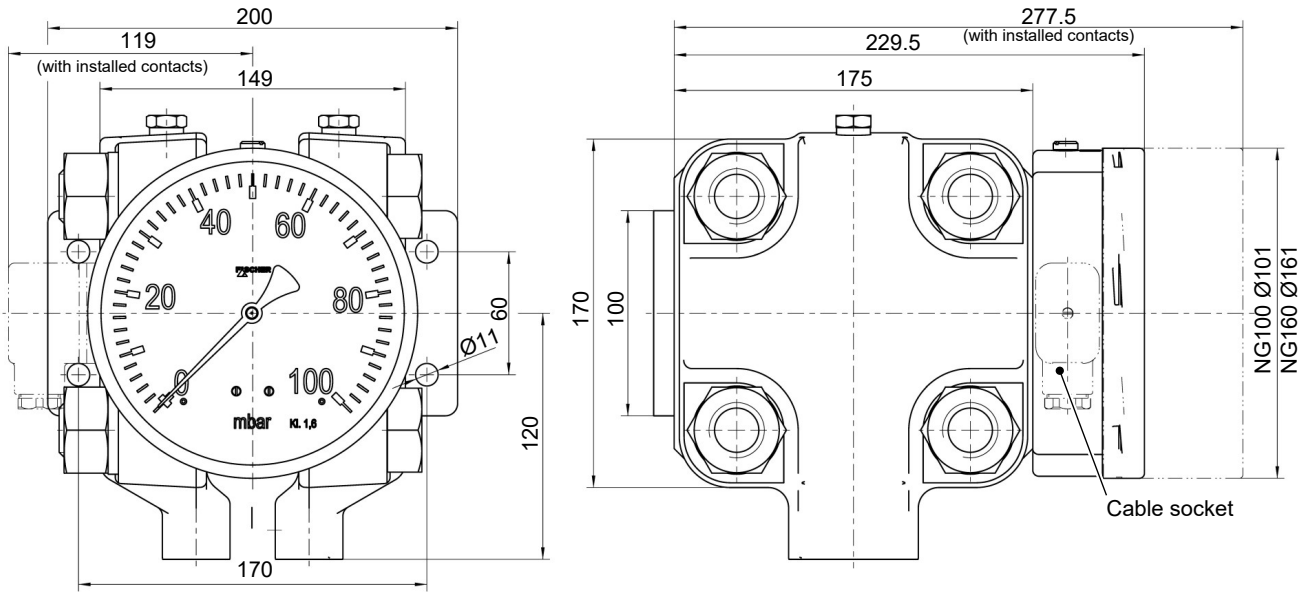
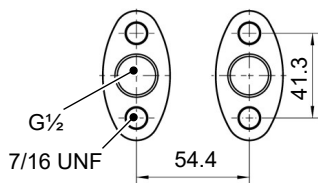

Fig. 13: Pipe mounting

Large measuring system (Ø130)



Flange based on DIN EN 61518



Wall mounting plate

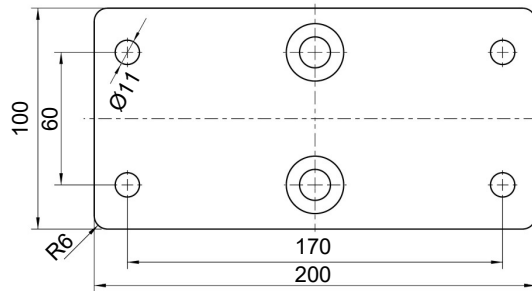
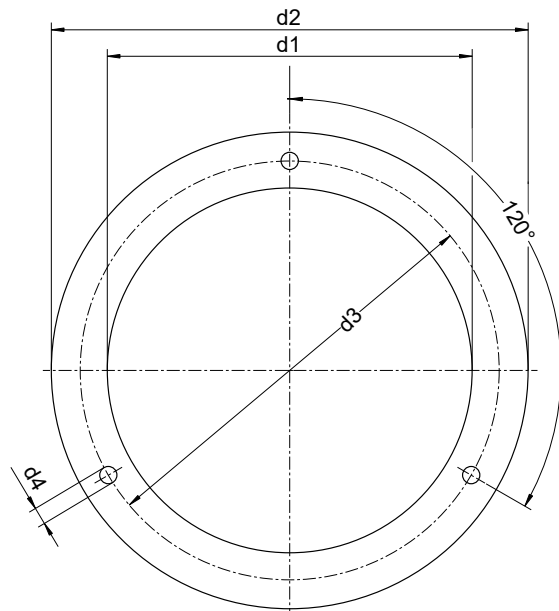
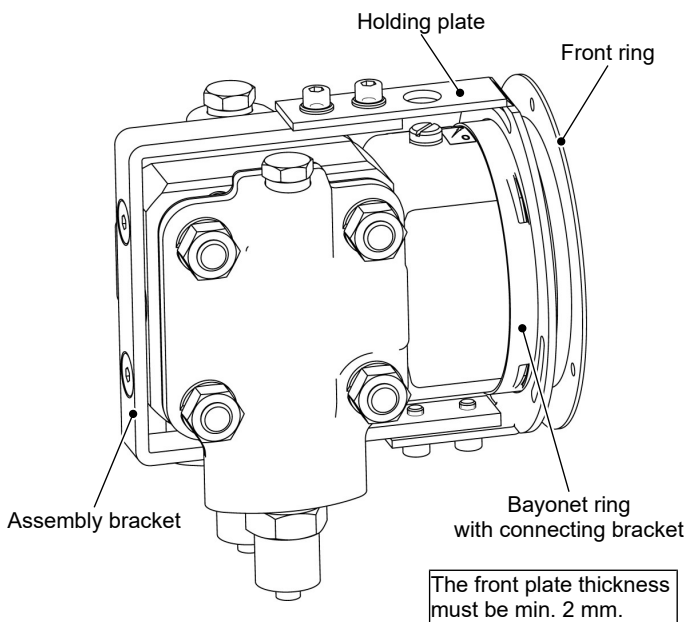

Fig. 14: Dimensional drawing (Large measuring system Ø130)

Installation of front panel type 1

(only small measuring system Ø75 and NG100 display)



	d1	d2	d3	d4
NG100	101	132	116	4.8

Fig. 15: Installation of front panel with panel fittings

Installation of front panel type 2

The front plate thickness must be min. 2 mm.

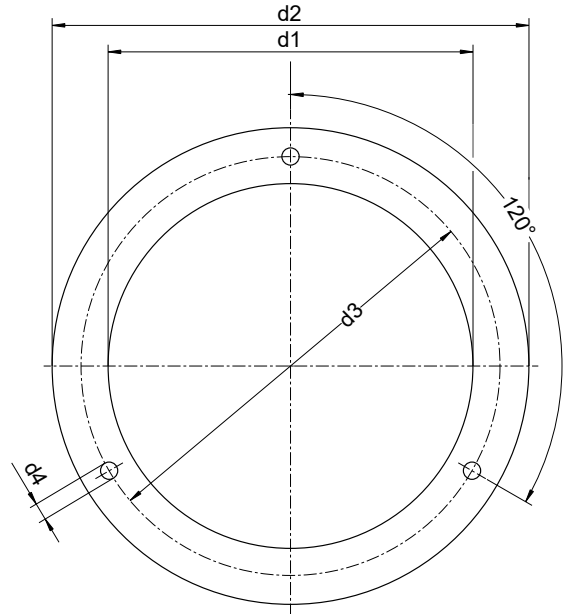
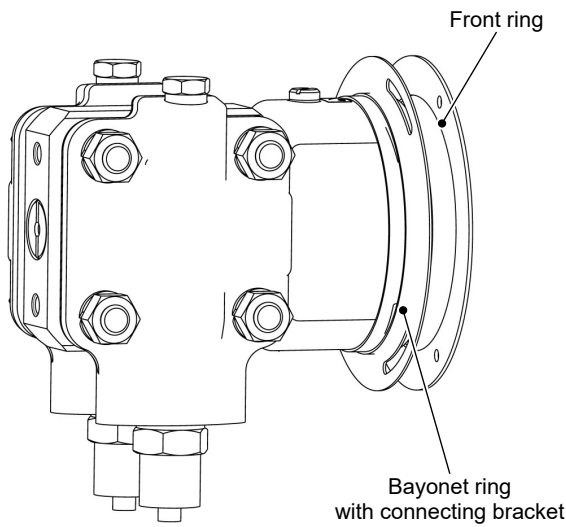

	d1	d2	d3	d4
NG100	101	132	116	4.8
NG160	161	196	178	5.8

A suitable steel construction must be used to ensure that the front plate can bear the weight of the device.

Examples:

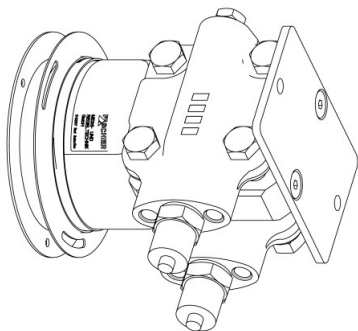

Assembly on a mounting plate

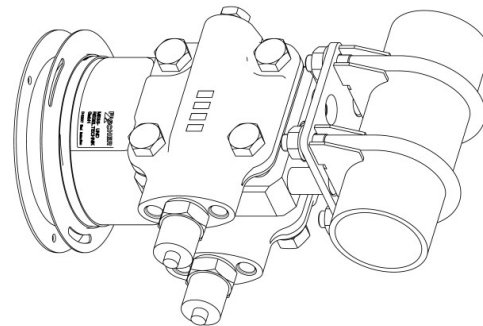

Mounting to a 2" pipe

Fig. 16: Installation of front panel with front ring

Contact elements

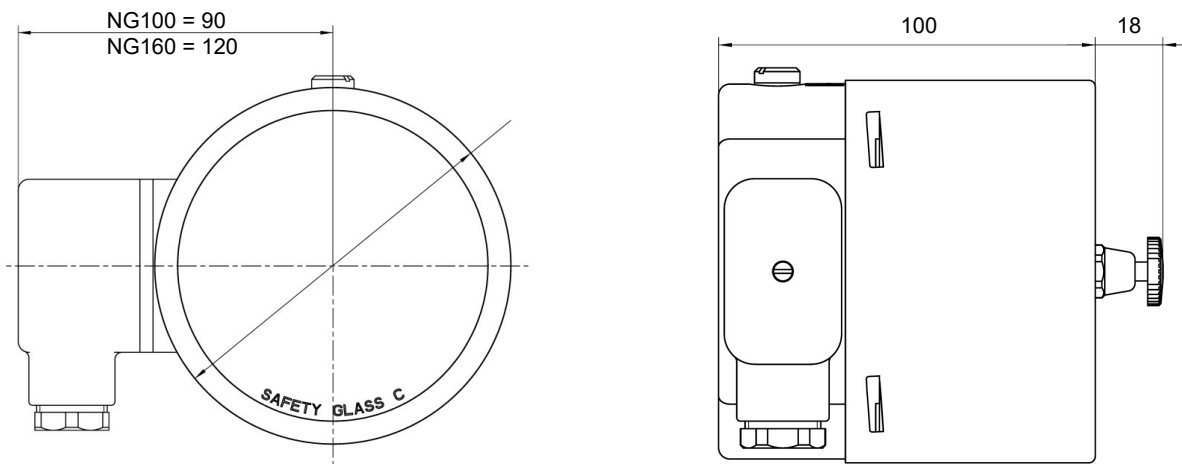

Fig. 17: Dimensional drawing of contact device

Shut-off fitting

with inner spindle thread

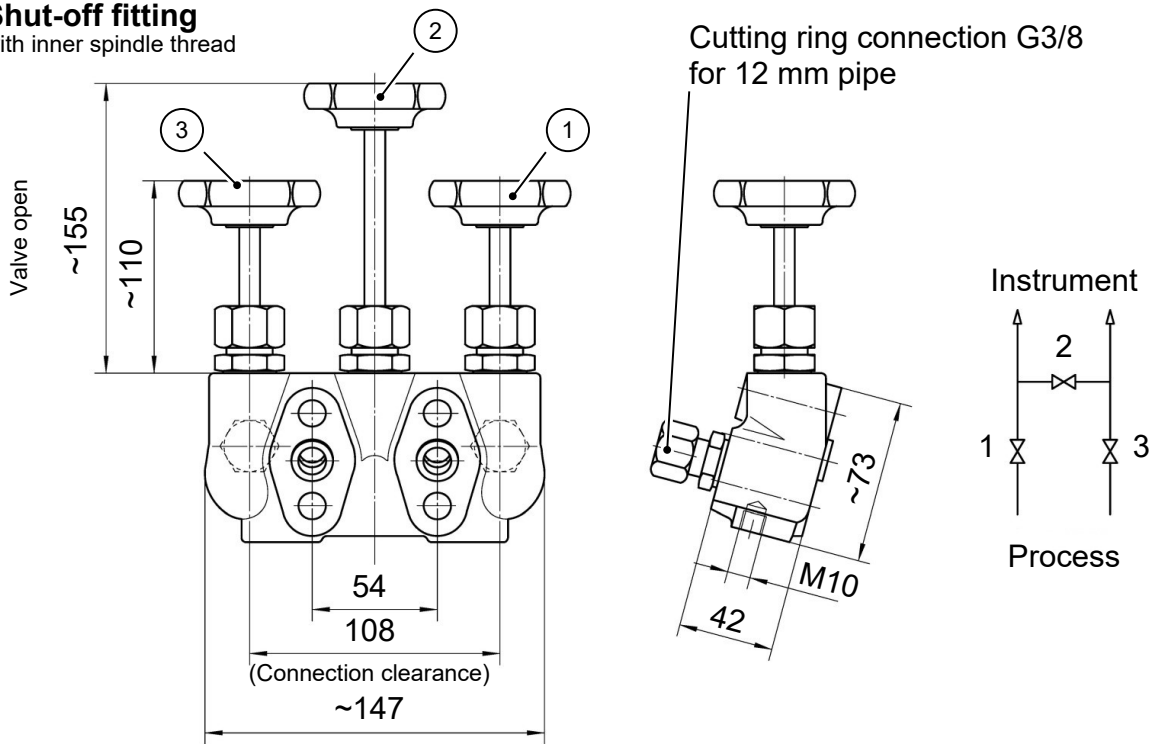
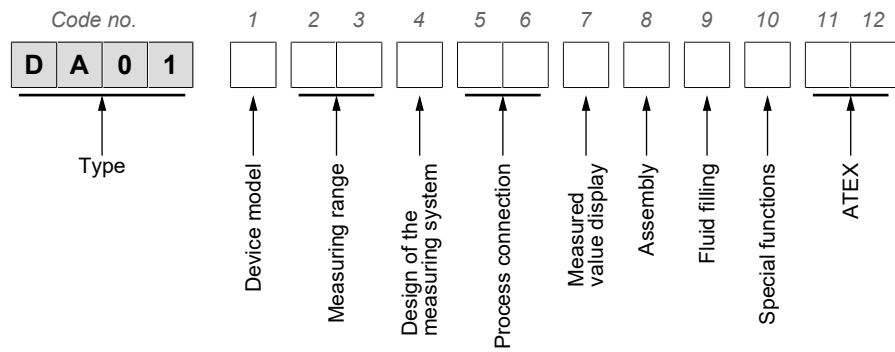

Fig. 18: Shutoff valve DZ3600SV2700

3 Order Codes



Device model:

[1]	Pressure level	Measuring cell
V	PN250	Ø75
U	PN400	Ø75
W	PN250	Ø130

Measuring range:

Small measuring system
Ø75

[2.3]	Measuring range	Device model		
		V	U	W
01	0 ... 0.6 bar	•	•	
02	0 ... 1 bar	•	•	
03	0 ... 1.6 bar	•	•	
04	0 ... 2.5bar	•	•	
05	0 ... 4.0 bar	•	•	
06	0 ... 6 bar	•	•	
07	0 ... 10 bar	•	•	
08	0 ... 16 bar	•	•	
09	0 ... 25 bar	•	•	
99	Special measuring ranges	•	•	

Large measuring system
Ø130

[2.3]	Measuring range	Device model		
		V	U	W
57	0 ... 40 mbar			•
58	0 ... 60 mbar			•
59	0 ... 100 mbar			•
60	0 ... 160 mbar			•
82	0 ... 250 mbar			•
83	0 ... 400 mbar			•
99	Special measuring ranges			•

Design of the measuring system:

[4]	
R	Pressure chamber CrNi steel 1.4404 (AISI 316L) Measuring membrane standard
G	Pressure chamber CrNi steel 1.4404 (AISI 316L) Measuring membrane Hastelloy C276

Process connection:

[5.6]	
03	Flange connection based on DIN EN 61518 with internal thread G $\frac{1}{2}$
04	Connecting piece G $\frac{1}{2}$ with inside thread 1/4 -18 NPT
05	Connecting piece G $\frac{1}{2}$ with inside thread 1/2 -14 NPT
13	Connection shanks G $\frac{1}{2}$ with external thread G $\frac{1}{2}$
14	Connecting port G $\frac{1}{2}$ with outer thread 1/4-18 NPT
15	Connecting port G $\frac{1}{2}$ with outer thread 1/2-14 NPT
27	Cutting ring connection in brass for 12 mm pipe

Measured value display:

[7]	
L	Bayonet ring housing NG100
M	Bayonet ring housing NG160

Assembly:

[8]	
W	Wall mounting
R	Pipe mounting
T	Panel installation fittings (only a small measuring system Ø75, NG100 measured value display without contact elements)
G	Front ring for panel mounting

Fluid filling:

[9] Only devices without contact device	
0	Without fluid filling
1	Glycerine
4	Paraffin oil
5	Silicon oil

Special functions:

[10]	
0	Without special function
1	Adjustable marker needle
2	Resettable drag needle

Contacts/transmitters/ATEX:

[11.12] ATEX model		
0A	Non-electrical unit (without switch contacts)	II 2G Ex h IIC T4 Gb II 2D Ex h IIIC T95°C Db
1B	Unit with magnetic spring contacts KE##M##0B4H2 Simple electrical operating equipment acc. to DIN EN 60079-11	II 2G Ex h IIC T4 Gb
1C	Unit with inductive contacts KE###0C0H2	II 2G Ex h IIC T4 Gb II 2D Ex h IIIC T95°C Db

Limitations

A minimum operating pressure, which not all measuring ranges achieve, is required to activate a contact element or a drag indicator. Please also note the information about the equipment features.

3.1 Accessories

Order no.	Planned measures	Material
DZ3600SV2700	Triple valve block DN5 PN420 <ul style="list-style-type: none"> • Flange connection acc. to DIN EN 61518 • Cutting ring screw connections 12 mm pipe • Including assembly set 	1.4571

Order no.	Planned measures	Type
05003065	Isolating unit amplifier 1-channel 24 V DC	TS500Ex-ia-1R-5
05003066	Isolating unit amplifier 2-channel 24 V DC	TS500Ex-ia-2R-5
05003083	Isolating unit amplifier 1-channel 230 V AC	TS500Ex-ia-1R-0
05003084	Isolating unit amplifier 2-channel 230 V AC	TS500Ex-ia-2R-0
05003070	Universal supplier isolator	ST500Ex-10-5
05003086	Universal supplier isolator	ST500Ex-10-0

3.2 Information about the document

This document contains all technical data about the device. Great care was taken when compiling the texts and illustrations; Nevertheless, errors cannot be ruled out.

Subject to technical amendments.



FISCHER Mess- und Regeltechnik GmbH

Bielefelder Str. 37a
D-32107 Bad Salzuflen

Tel. +49 5222-974-0

Fax. +49 5222-7170

web : www.fischermesstechnik.de

eMail : info@fischermesstechnik.de

