

CE
RoHS III
COMPLIANT
UK
CA
EAC



Data sheet

DE39

Digital differential pressure transmitter
with colour-change LCD

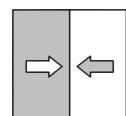

1 Product and functional description

1.1 Performance features

Typical applications

- Differential pressure measurements in heavily soiled media
- Filter monitoring
- Simple pump control systems
- Pump and compressor monitoring

Important features

- 4-digit colour change LCD
- Selectable operating mode
 - Differential pressure measurement
 - 2-channel relative pressure measurement.
- Selectable pressure unit (bar, mbar, Pa, kPa, MPa, psi, InWc, mmHg)
- Selectable measured value display
 - Single-line presentation (channel 1 or channel 2)
The respective other channel can be shown using the button ▲
 - Two-line presentation (both channels)
- Zero point correction
- Signal damping
- 2 programmable output signals (current/voltage)
- Characteristic curve spread (max. 10:1) with freely selectable offset
- Characteristic curve implementation via table (with max. 30 measuring points)
- Full parameter setting and measuring point protocol possible thanks to optionally available transmitter PC interface

1.2 Intended use

The devices of the series DE39 can be used as display and switching device for measuring differential pressure of gaseous and fluid media. Its sturdy design also allows heavily contaminated media to be used. Always check the medium compatibility [► 5].

1.3 Design and mode of operation

The pressure is measured by two integrated ceramic sensor elements whose measuring signals P+ and P- are analysed by a digital measuring transducer. The analysis allows two independent switching points to be set and makes two programmable output signals available. The measurements can be shown together, separately or alternately. The nominal pressures of the integrated sensors and the differential pressure measuring range are set permanently ex-works and stated on the type plate.

The unit works in two operating modes:

(a) Differential pressure

In this operating mode, both channels can be independently assigned to the input signals (P+) and (P-). In addition, the differential pressure (dP) or a function (Fct.) can also be assigned as desired. With the function, each output signal can be square rooted or a characteristic curve can be defined by means of a table.

(b) 2-channel

In this operating mode, the output (Sig1) is permanently assigned to the pressure (P+) and the output (Sig2) to the pressure (P-). The function is used to square root both output signals or to define a characteristic curve by means of a table.

1.4 Function diagram

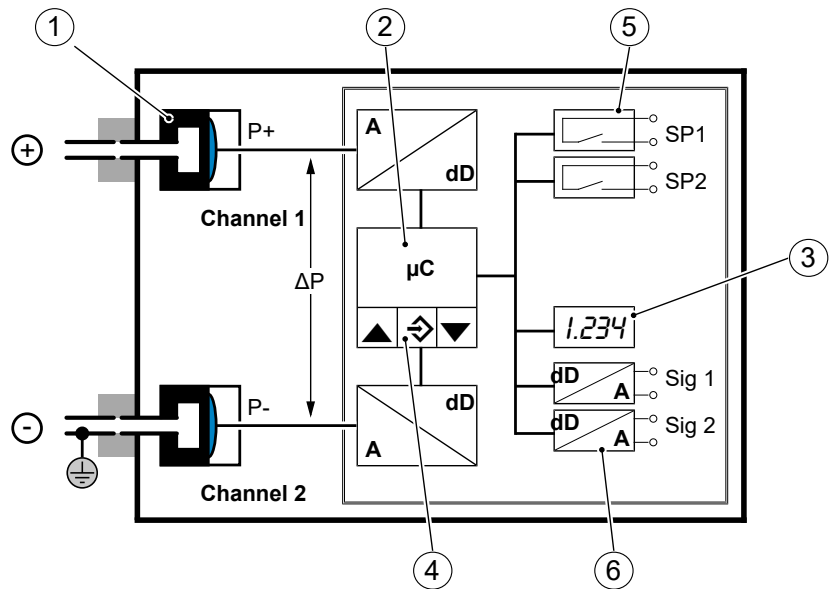

Fig. 1: Function diagram

1	Ceramic sensor element	2	Micro-controller
3	Advertisement	4	Keyboard
5	Switching outputs	6	Analogue outputs

1.5 Equipment versions

The appearance of the various models differs in terms of the process connection.

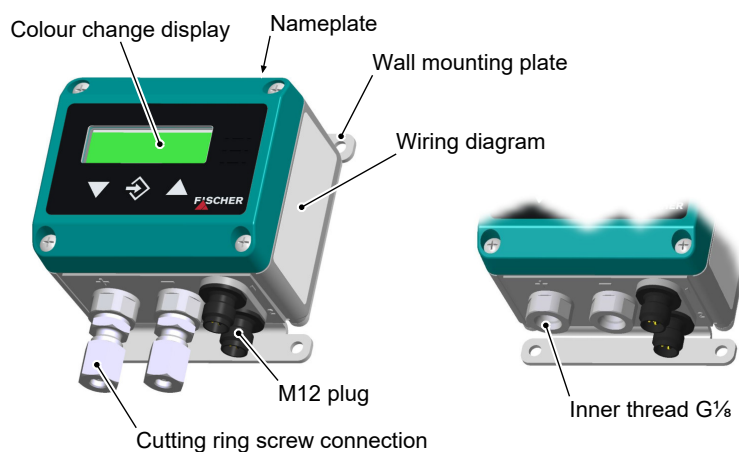

Fig. 2: Equipment versions

2 Technical data

2.1 Input variables

Measuring variable

Differential and relative pressure

Measuring range

Measuring range		Stat. operating pressure max.	Overpressure	Bursting pressure
bar	MPa	bar	bar	bar
0...6	0...0.6	6	20	35
0...10	0...1.0	10	40	70
0...16	0...1.6	16	40	70
0...25	0...2.5	25	100	150
0...40	0...4.0	40	100	150

2.2 Output sizes

Analogue output signal

Connection type: Three-wire

Max. Spread: 10:1

Outlet	Signal range	Apparent ohmic resistance
0 ... 20 mA	0.0 ... 21.0 mA	$U_b \leq 26 \text{ V} : R_L \leq (U_b - 4 \text{ V})/0.02 \text{ A}$
4 ... 20 mA		$U_b > 26 \text{ V} : R_L \leq 1100 \Omega$
0 ... 10 V	0.0 ... 11.0 V	$R_L \geq 2 \text{ k}\Omega$

Switching outputs

2 potential-free relay contacts

2 potential-free semiconductor switches (MOSFET)

	Relay	MOSFET
Progr. switching function	Open contact (NO) Break contact (NC)	One-pin activator (NO) One-pin deactivator (NC)
Max. switching voltage	32 V AC/DC	3...32 V AC/DC
Max. switching current	2 A	0.25 A
Max. switching output	64 W / 64 VA	8 W / 8 VA $R_{ON} \leq 4 \Omega$

2.3 Measurement accuracy

Non-linearity	Max	0.5 % FS
	Typical	0.2 % FS
Hysteresis	Max	0.5 % FS
	Typical	0.2 % FS
Characteristic curve deviation ¹⁾	Max	1.0 %
Temperature drift	Zero point	0.07 % FS/K
	Measuring range	0.05 % FS/K

¹⁾ incl. non-linearity and hysteresis

2.4 Auxiliary energy

Rated Voltage	24 V AC/DC
Allowed operating voltage	12 ... 32 V AC/DC
Power input	approx. 2 W (VA)

2.5 Operating conditions

Increase ambient temperature	-10 ... +70 °C
Media temperature	-10 ... +80 °C
Storage temperature	-20 ... +70 °C
Enclosure protection class	IP65 as per EN 60529
EMC	EN 61326-1:2013 EN 61326-2-3:2013
RoHS	EN IEC 63000:2018

2.6 Display and operating interface

Advertisement

4...6-digit LCD, full graphic, colour backlighting

Programming

Attenuation	0.0 ... 100.0 s (jump response time 10 / 90 %)
Switch output	Switch-off point, switch-on point, response time (0...1800s), function (NC / NO contact), channel assignment
Measuring range unit	bar, mbar, Pa, kPa, MPa, psi, InWc, mmWs, mmHg, 'free unit', starting value, end value and decimal point for 'free unit'
Output signal	User-definable within the basic measuring range ⁽¹⁾
Zero-point window	0... $\frac{1}{3}$ of the basic measuring range ⁽²⁾
Offset correction	$\pm\frac{1}{3}$ of the basic measuring range ⁽³⁾
Implementation of characteristic curve	linear, square rooted, table with 3...30 support points
Password	001 ... 999 (000 = no password protection)
Language (can be switched)	DE, EN, FR, ES, IT, PT, and HU

(1) Max. effective spread 10:1

(2) measured values around zero are set to zero.

(3) To compensate different installation positions.

2.7 Construction design

Process connection

Type	the material.	Size
Inner thread	1.4404	G $\frac{1}{8}$
Cutting ring screw connection	1.4571	6 mm tube
Cutting ring screw connection	1.4571	8 mm tube
Cutting ring screw connection	Nickel-plated brass	6 mm tube
Cutting ring screw connection	Nickel-plated brass	8 mm tube

Materials

Housing	Polyamide (PA) 6.6
Media-contacting material	CrNi steel 1.4404, FKM, Rubalit® 708 + Process connection (see above)

Assembly

Attachment boreholes on the rear side for attachment to mounting plates.

Wall mounting using wall mounting plate

Panel mounting set for installing the panel

Assembly of the mounting rails using an adapter

Dimensional drawings

Wall mounting

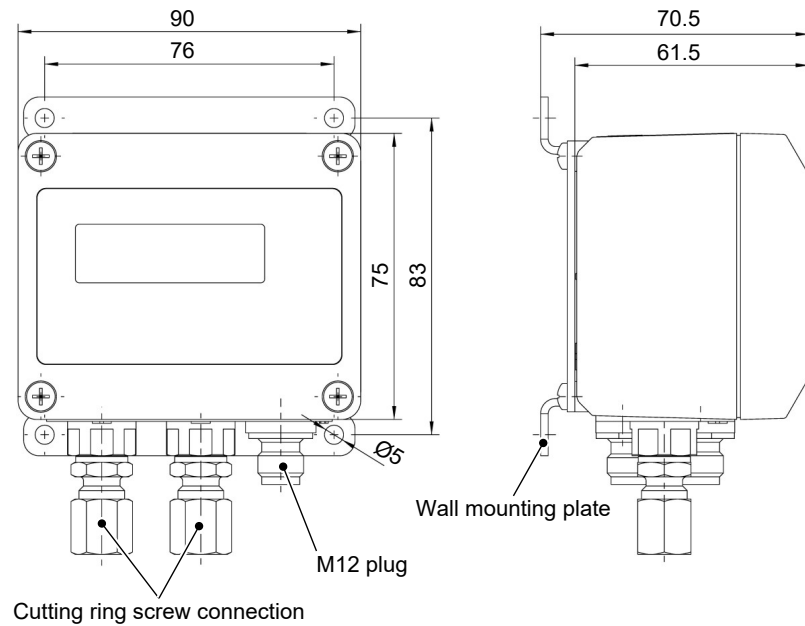

Fig. 3: Dimensional picture

Attachment boreholes on rear side

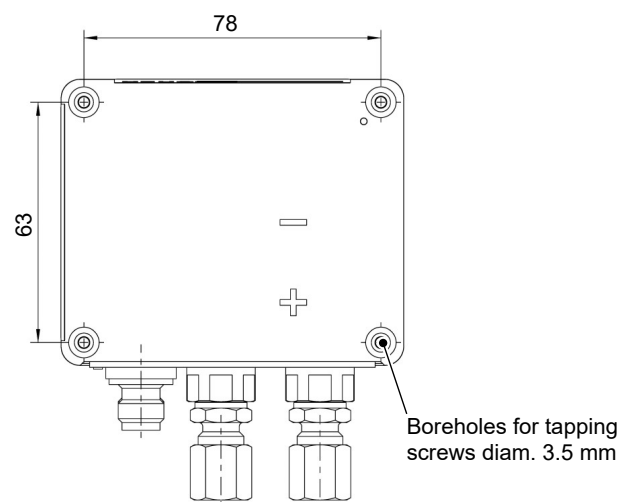
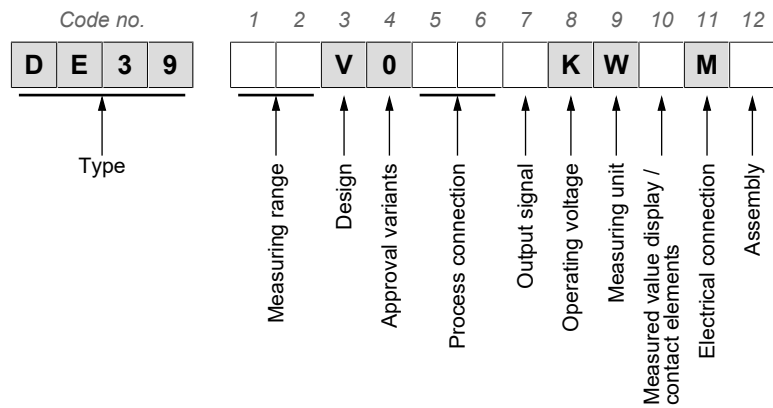

Fig. 4: Rear view of dimensional picture

3 Order Codes



Measuring range:

[1.2] (Code no.)	
06	0...6 bar
07	0...10 bar
08	0...16 bar
09	0...25 bar
10	0...40 bar

Design:

[3] (Code no.)	
R	CrNi Steel 1.4404

Approval variants:

[4] (Code no.)	
0	Default

Process connection:

[5.6] (Code no.)		
00	Inner thread G $\frac{1}{8}$	
24	Cutting ring screw connection made of 1.4571	for 6 mm tube
25	Cutting ring screw connection made of 1.4571	for 8 mm tube
28	Cutting ring connection made of brass galvanised	for 6 mm tube
29	Cutting ring connection made of brass galvanised	for 8 mm tube

Output signal:

[7] (Code no.)	
0	without output signal
4	0 ... 20 mA
5	0 ... 10 V
6	4 ... 20 mA

Operating voltage:

[8] (Code no.)	
K	24 V AC/DC

Measuring unit:

[9]	(Code no.)
W	Selectable pressure units

Measured value display / contact elements:

[10]	(Code no.)	
C	4-digit colour change LCD	2 relay contacts
dD	4-digit colour change LCD	2 semiconductor switches

Electrical connection

[11]	(Code no.)
M	M12 plug connection

Assembly:

[12]	(Code no.)
0	Attachment boreholes on rear side (standard)
W	Wall mounting

3.1 Accessories

Order no.	Designation	No. of Poles	length
06401993	M12 Connection cable for switching outputs	4-pin	2m
06401994	M12 Connection cable for switching outputs	4-pin	5m
06401563	M12 Connection cable for switching outputs	4-pin	7m
06401572	M12 Connection cable for switching outputs	4-pin	10m
06401995	M12 Connection cable for supply/signal	5-pin	2m
06401996	M12 Connection cable for supply/signal	5-pin	5m
06401564	M12 Connection cable for supply/signal	5-pin	7m
06401573	M12 Connection cable for supply/signal	5-pin	10m

Remote configuration

Order no.		
EU05 0000	Transmitter PC interface incl. PC software	without battery
EU05 0001	Transmitter PC interface incl. PC software	With battery
EU03 F300	Transmitter PC interface incl. PC software	

A data sheet is available on our website www.fischermesstechnik.de or on request.

3.2 Information about the document

This document contains all technical data about the device. Great care was taken when compiling the texts and illustrations. nevertheless, errors cannot be ruled out.

Subject to technical amendments.

Notes

Notes

Notes



FISCHER Mess- und Regeltechnik GmbH

Bielefelder Str. 37a
D-32107 Bad Salzuflen

Tel. +49 5222 974-0

Fax +49 5222 7170

www.fischermesstechnik.de
info@fischermesstechnik.de