

II 3G Ex nA IIC T4 Gc
II 3D Ex tc IIIB T125°C Dc

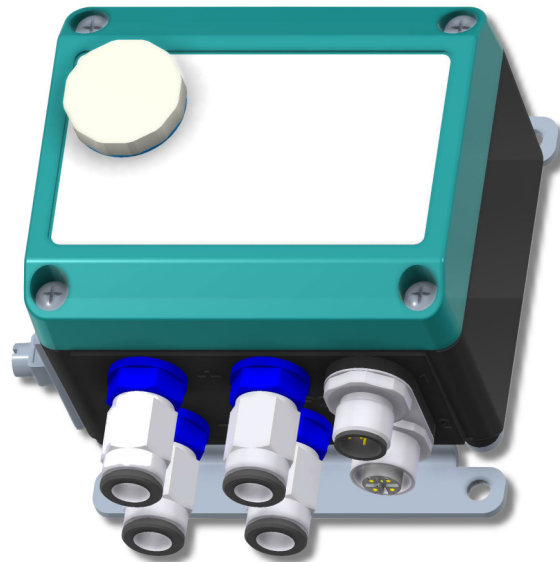

Data sheet

DE43 ... R####

Digital 2-channel transmitter
for direct connection to bus-capable automation devices

Version for potentially explosive areas
Gas explosion protection Zone 2, Gases and vapours
Dust explosion protection Zone 22, dry dusts

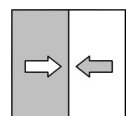

1 Product and functional description

1.1 Performance characteristics

Typical applications

- Air-conditioning technology
- Ventilation technology
- Environmental technology
- Monitoring of automatic roll filters, extraction systems etc.
- Metering at cowls
- Flow and control pressure measurements
- Surface technology

Important features

- Durable and resistant to overpressure
- Maintenance-free
- Two independent differential pressure sensors
- Bus-capable via RS-485 with Modbus-RTU protocol
- Optional connection for external contacts
- Address setting and configuration mechanical via coding switch
- Calibrated and configured ex-works
- Use in areas at risk of explosion

Zone 2 ⓧ II 3G Ex nA IIC T4 Gc

Zone 22 ⓧ II 3D Ex tc IIIB T125°C Dc

1.2 Equipment versions

Assembly

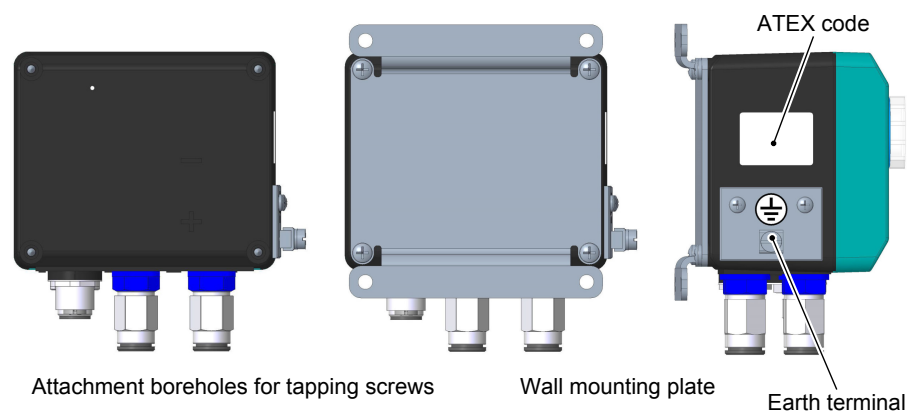
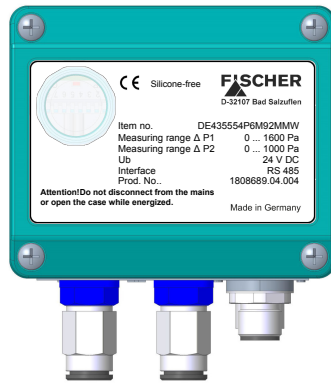
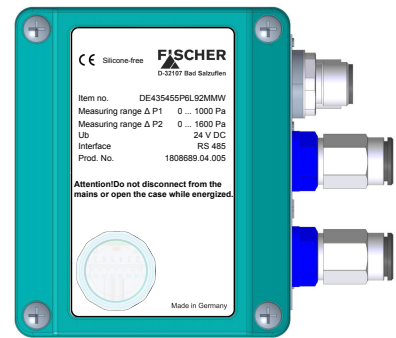

Fig. 1: Wall mounting



Standard version



90° rotated

Fig. 2: Type plate

Process connection

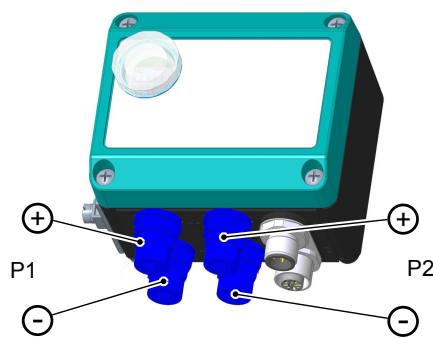

Stainless steel CK screw connection for 6/4 or 8/6 mm hose

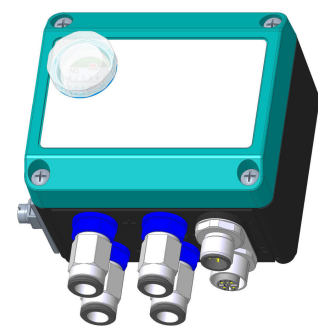

Pneumatic plug connection for 6/4 or 8/6 mm hose

Fig. 3: Process connection

Electrical connections

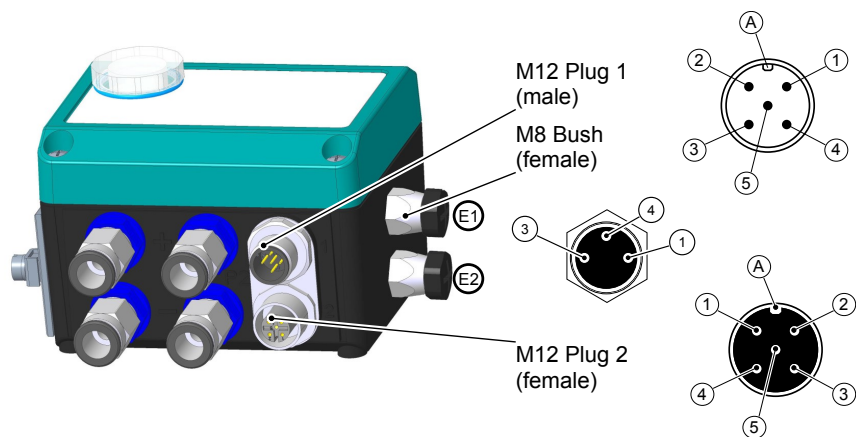

Fig. 4: Electrical connections

1.3 Function diagram

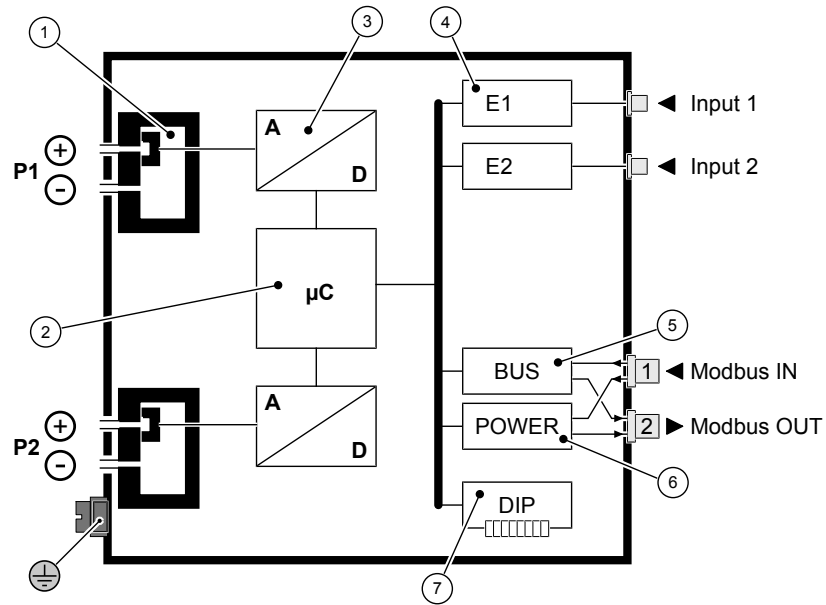

Fig. 5: Function diagram

1	Sensor element	2	Micro-controller
3	AD converter	4	Digital inputs
5	Modbus interface	6	Power Supply
7	Modbus configuration	⊕	Electrostatic earthing

1.4 Design and mode of operation

The basis of the DE43 transmitter comprises two piezoresistive sensor elements.

The pressure that is to be measured acts upon a silicone membrane that is equipped with a resistor bridge. The acting pressure causes the membrane to move and therefore a change in resistance. The bridge signal is analysed by the integrated electronics and converted to a pressure value.

The DE43 transmitter communicates with an overriding control system via an RS 485 interface and a Modbus RTU protocol. The currently measured value is forwarded by the overriding control system on request.

The device also has a connecting slot for two or four proximity switches whose signals can also be queried through the Modbus by the overriding control system.

2 Technical data

2.1 General

General information	
Type designation	DE43
Pressure type	Differential pressure, relative pressure
Measurement principle	Piezo-resistive
Reference conditions (acc. to IEC 61298-1)	
Temperature	+15 ... +25 °C
Relative humidity	45 ... 75 %
Air pressure	86 ... 106 kPa 860 ... 1060 mbar
Installation position	User-defined

2.2 Input variables

Measuring variable	Pressure, under-pressure and differential pressure for neutral gaseous media
Damping (P=10...90%)	1 sec

		Unit	+ ranges (0 ... +p)					+ ranges (-p ... +p)				
Measuring range (p)		PA	400	600	1000	1600	2500	±250	±400	±600	±1000	±1600
		kPa	0.4	0.6	1	1.6	2.5	±0.25	±0.4	±0.6	±1	±1.6
		mbar	4	6	10	16	25	±2.5	±4	±6	±10	±16
Max. stat. operating pressure		mbar	50	50	100	100	100	50	50	50	100	100
Bursting pressure		mbar	150	150	300	300	300	150	150	150	300	300
Characteristic curve deviation ^(*)	Max.	%FS						1.0				
	Type	%FS						0.5				
TK Span ^{**)}	Max.	%FS/10K	1.0	1.0	0.3	0.3	0.3	1.0	0.5	0.3	0.3	0.3
	Type	%FS/10K						0.3				
TK zero-point ^{**)}	Max.	%FS/10K	1.0	1.0	0.4	0.4	0.4	1.0	0.5	0.4	0.4	0.4
	Type	%FS/10K						0.2				

^{*)} Characteristic curve deviation (non-linearity and hysteresis) at 25°C

^{**)} Compensation range 0...60 °C

2.3 Communication parameter

interface	RS 485
Report	Modbus RTU
Modbus specification	Application Protocol Specification V1.1b3 (April 26, 2012)
Address	1 ... 127
Baud rate	1200 ... 57600 Baud
Parity	Even, uneven, parity
Stopbits	1...2

Pre-set data format

Baud rate	9600 Baud
Parity	None
Stopbit	1

Supported Modbus functions

0x02	Read Discrete Inputs
0x03	Read Holding Registers
0x04	Read Input Registers
0x2B / 0x0E	Read Device Identification

For more information about this, please refer to the operating instructions and online http://www.modbus.org/docs/Modbus_Application_Protocol_V1_1b3.pdf.

2.4 Auxiliary energy

nominal voltage	24 V DC
Admissible operating voltage	18 ... 30 V DC
Absorbed power	Max. 2 W

2.5 Operating conditions

Ambient temperature range	-10 ... +60 °C
Storage temperature range	-20 ... +70 °C
Medium temperature range	-10 ... +70 °C
Protection	IP65
ATEX	EN 60079-0:2012 + A11:2013 EN 60079-15:2010 EN 60079-31:2014
EMC	EN 61326-1:2013 EN 61326-2-3:2013
RoHS	EN 50581:2012

3 Order codes

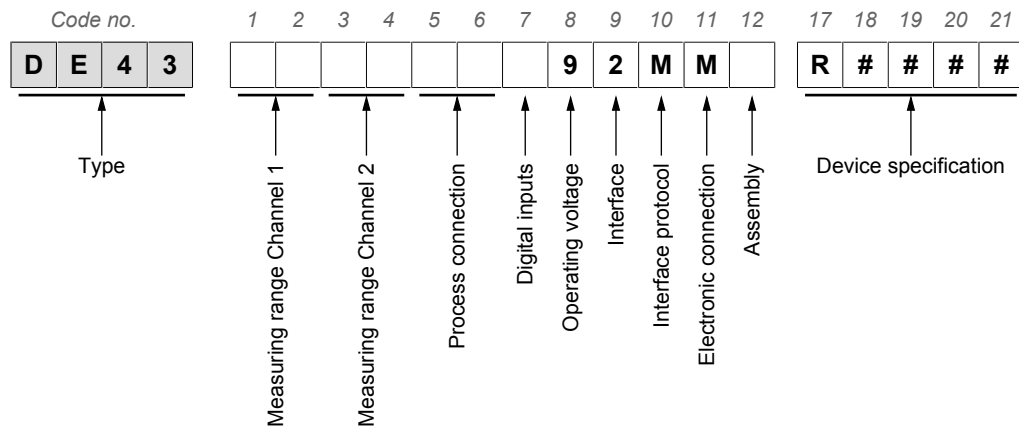

Measuring range channel 1:

[1.2]	[Pa]
D7	0 ... 400
D8	0 ... 600
D9	0 ... 1000
E1	0 ... 1600
E2	0 ... 2500 Pa
S6	-250 ... +250
R1	-400 ... +400
R2	-600 ... +600
R3	-1000 ... +1000
R4	-1600 ... +1600

Measuring range channel 2:

[1.2]	[Pa]
D7	0 ... 400
D8	0 ... 600
D9	0 ... 1000
E1	0 ... 1600
E2	0 ... 2500 Pa
S6	-250 ... +250
R1	-400 ... +400
R2	-600 ... +600
R3	-1000 ... +1000
R4	-1600 ... +1600

Process connection:

[5.6]	
40	CK aluminium screw connection for 6/4 mm hose
41	CK aluminium screw connection for 8/6 mm hose
P6	Pneumatic plug connector MS nickel-plated for 6/4 mm hose
P8	Pneumatic plug connector MS nickel-plated for 8/4 mm hose

Digital inputs:

[7]	M8 round plug connector 3-pin, female
0	Without digital inputs
K	Two digital inputs (E1, E2) right

Operating voltage:

[8]	
9	24 V DC

Interface:

[9]	
2	RS 485

Interface protocol:

[10]	(Code no.)
C	Modbus RTU Protocol



Electrical connection:

[11]	
C	M12 round plug connector (Modbus, power supply) M8 round plug connector (Digital inputs, optional→[7])

Assembly:

[12]	
0	Standard (attachment boreholes on rear side)
W	Horizontal wall mounting
V	Vertical wall mounting

Device specification

[17-21]	Device specification
R####	Version for use in areas at risk of explosion Zone 2 and Zone 22
	CE  II 3G Ex nA IIC T4 Gc
	CE  II 3D Ex tc IIIB T125°C Dc

3.1 Information about the document

This document contains all technical data about the device. Great care was taken when compiling the texts and illustrations; Nevertheless, errors cannot be ruled out.

Subject to technical amendments.

**FISCHER Mess- und Regeltechnik GmbH**

Bielefelder Str. 37a
D-32107 Bad Salzuffen
Tel. +49 5222-974-0
Fax. +49 5222-7170

web : www.fischermesstechnik.de
eMail : info@fischermesstechnik.de