



II 3G Ex nA IIC T4 Gc
II 3D Ex tc IIIB T125°C Dc



Data sheet

ME12 ... R/S

Remotely configurable digital pressure transducer
for use in explosive areas

Gas explosion protection Zone 2
Dust explosion zone 22

09005485 • DB_EN_ME12_ATEX • Rev. ST4-E • 10/22

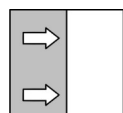

1 Product and functional description

1.1 Performance characteristics

Important features

- Can be configured
- Robust device model
- Highly precise
- Low hysteresis

Typical applications

- Relative pressure measurements
- Absolute pressure measurements

Application areas

- Procedural engineering
- Process technology
- Environmental technology

1.2 Product overview

The following provide an overview of the possible connectors and process connections. The code stated corresponds to the respective code in the order code.

Electrical plug

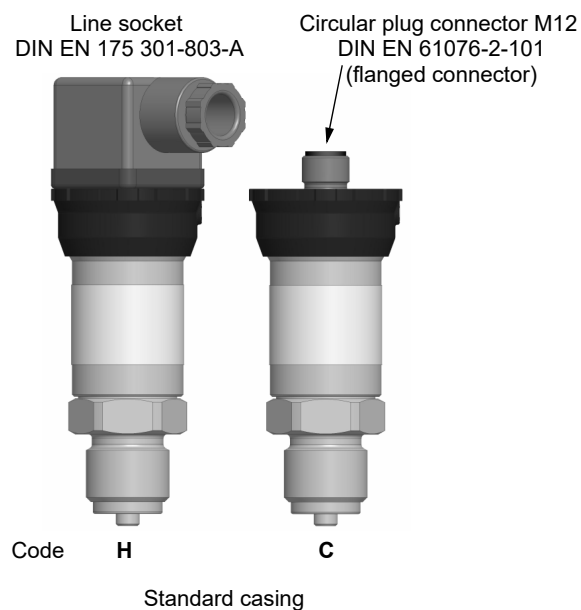
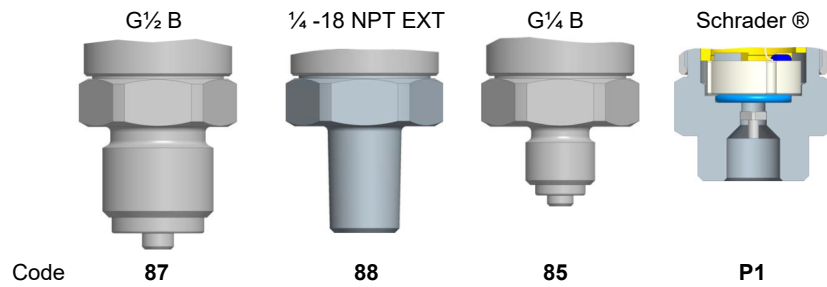
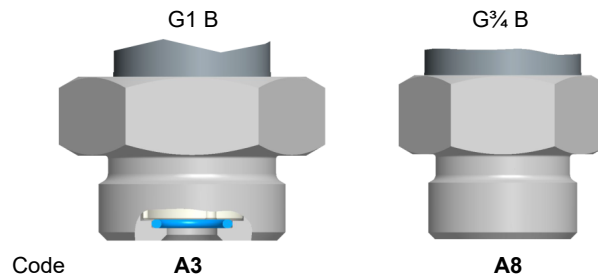

Fig. 1: Electrical plug

Process connections



Near flush-mounted front sensor



Code **A3** **A8**
 Fig. 2: Process connections

1.3 Use as intended

The ME12 is a pressure transmitter with a ceramic measuring cell for over-pressure and under-pressure and can be used for both relative and also absolute pressure measurements. The pressure transmitter can be used with non-aggressive liquid and gaseous media. Please see the technical data for the respective measuring ranges.

ATEX classification

Zone 22

ME12 pressure transmitters are suitable for use as 'Electrical equipment for use in areas with combustible dust', zone 22 - dry dust.
 The units are identified with

CE UK Ex II 3D Ex tc IIIB T125°C Dc

Zone 2

ME12 pressure transmitters are suitable for use as 'Electrical equipment for use in areas with combustible gases', zone 2.
 The units are identified with

CE UK Ex II 3G Ex nA IIC T4 Gc

1.4 Function diagram

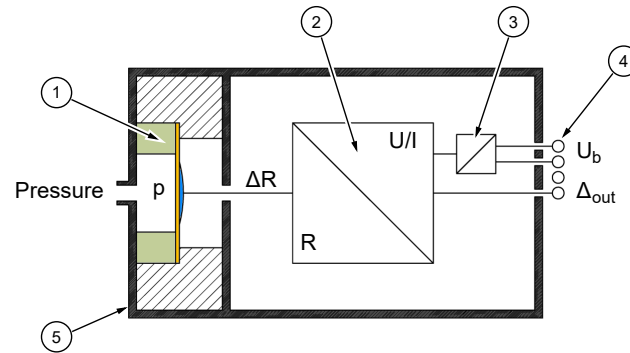

Fig. 3: Function diagram

1	Ceramic sensor	2	Electronics
3	Auxiliary energy	4	Electrical connection
5	Process connection		

1.5 Design and mode of operation

The pressure sensor works on the thick layer technology DMS principle. The measured pressure acts directly onto a ceramic membrane that deforms when under pressure. This changes the resistance of the attached DMS bridge. Electronics integrated into the device convert this bridge signal into an electronic output signal.

Every pressure transmitter is programmed according to the code in the order code on delivery. Also, the electrical connections can be used to configure the pressure transmitter, adapting it ideally to suit the process conditions. You will need a Transmitter PC Interface available as an accessory.

2 Technical data

2.1 Generalities

Reference conditions (acc. to IEC 61298-1)		
Temperature error	+15 ... +25 °C	
Relative humidity	45 ... 75 %	
Air pressure	86 ... 106 kPa	860 ... 1060 mbar
Auxiliary energy	24 V DC	
Installation position	User-defined	

2.2 Input variables

Messgröße

Relative pressure

Pressure in non-aggressive liquid and gaseous media.

Measuring		Pressure safety		Characteristic curve deviation	
[bar]	[kPa]	Overpres- sure	Bursting pressure	Option	Standard
0 ... +0.6	0 ... 60	4 bar	7 bar	---	1.0 %FS
0 ... +1	0 ... 100	4 bar	7 bar	0.5%FS	1.0 %FS
0 ... +1,6	0 ... 160	4 bar	7 bar	0.5%FS	1.0 %FS
0 ... +2.5	0 ... 250	10 bar	15 bar	0.5%FS	1.0 %FS
0 ... +4	0 ... 400	10 bar	15 bar	0.5%FS	1.0 %FS
0 ... +6	0 ... 600	20 bar	35 bar	0.5%FS	1.0 %FS
0 ... +10	0 ... 1000	40 bar	70 bar	0.5%FS	1.0 %FS
0 ... +16	0 ... 1600	40 bar	70 bar	0.5%FS	1.0 %FS
0 ... +25	0 ... 2500	100 bar	150 bar	---	1.0 %FS
0 ... +40	0 ... 4000	100 bar	150 bar	---	1.0 %FS
0 ... +60	0 ... 6000	200 bar	250 bar	---	1.0 %FS

Absolutdruck

Measuring		Pressure safety		Characteristic curve deviation	
[bar]	[kPa]	Overpres- sure	Bursting pressure	Option	Standard
0 ... +1	0 ... 100	4 bar	7 bar	0.5%FS	1.0 %FS
0 ... +1.6	0 ... 160	4 bar	7 bar	0.5%FS	1.0 %FS
0 ... +2.5	0 ... 250	10 bar	15 bar	0.5%FS	1.0 %FS
0 ... +4	0 ... 400	10 bar	15 bar	0.5%FS	1.0 %FS
0 ... +6	0 ... 600	10 bar	15 bar	0.5%FS	1.0 %FS
0 ... +10	0 ... 1000	20 bar	35 bar	0.5%FS	1.0 %FS
0 ... +16	0 ... 1600	20 bar	35 bar	0.5%FS	1.0 %FS

**Vakuum und
± Measuringe**

Measuring		Pressure safety		Characteristic curve deviation	
[bar]	[kPa]	Overpres- sure	Bursting pressure	Option	Standard
0 ... -1	0 ... -100	4 bar	7 bar	---	1.0 %FS
-1 ... 0	-100 ... 0	4 bar	7 bar	---	1.0 %FS
-1 ... +0.6	-100 ... +60	4 bar	7 bar	---	1.0 %FS
-1 ... +1.5	-100 ... +150	4 bar	7 bar	---	1.0 %FS
-1 ... +3	-100 ... +300	10 bar	15 bar	---	1.0 %FS
-1 ... +5	-100 ... +500	20 bar	35 bar	---	1.0 %FS
-1 ... +9	-100 ... +900	40 bar	70 bar	---	1.0 %FS
-1 ... +15	-100 ... +1500	40 bar	70 bar	---	1.0 %FS
-1 ... +24	-100 ... +2400	100 bar	150 bar	---	1.0 %FS

2.3 Output parameters

2-Conductor	
Output range	4 ... 20 mA
Limits	ca. 26 mA
Apparent ohmic resistance	$(U_b - 6V)/0.02A$

2.4 Measurement accuracy

Non-linearity	Maximum	0.5 % FS
	Typical	0.2 % FS
Hysteresis	Maximum	0.5 % FS
	Typical	0.2 % FS
Characteristic curve deviation ²⁾	Standard	1.0 %
	Option ¹⁾	0.5 %
Temperature drift	Zero point	0.07 % FS/K
	Measuring range	0.05 % FS/K

¹⁾ only possible for certain measuring ranges

²⁾ incl. non-linearity and hysteresis

2.5 Auxiliary energy

2-Conductor	
Rated Voltage	24 V DC
Admissible operating voltage	6 ... 30 V DC
Power consumption	≤ 1 W

2.6 Application conditions

Ambient temperature range	-10 °C ... +70 °C
Storage temperature range	-20 °C ... +85 °C
Medium temperature range	-10 °C ... +85 °C
ATEX	EN 60079-0:2012 + A11:2013 EN 60079-15:2010 EN 60079-31:2014
EMV	EN 61326-1:2013 EN 61326-2-3:2013
RoHS	EN IEC 63000:2018
Protection type	IP 65 acc. to EN 60529

Materials of the parts that come into contact with the surroundings	
Housing	CrNi Steel 1.4305
Device plug screw lid	Polypropylene, black
Device plug	Polyamide, brass, zinc
Cable socket	Polyamide, polycarbonate, brass, zinc

Materials of the parts that come into contact with the measuring medium	
Process connection	CrNi Steel 1.4404
Sensor membrane	Ceramic Al ₂ O ₃
Seal ¹⁾	FKM Fluorinated rubber, Viton®
	CR Chloroprene rubber, Neopren®
	EPDM Ethylene propylene diene rubber
	H-NBR Hydrogenated acrylonitrile butadiene rubber
	FFPM Perfluorinated rubber, Kalrez®

¹⁾ see order code

2.7 Parameters

The ME12 pressure transmitter is fully configured on delivery, however it can also be remotely configured on site. A PC, an interface, which is available as an accessory and the PC software **transmitter programmer** are required for configuration.

The EU13 with a USB interface is used for pressure transmitters with 2-line connections.

The following parameters can be set

Characteristic curve	Increasing / decreasing
Attenuation	0 ... 200 s
Offset correction	±25 %FS
Margin correction	±25 %FS

Signal limits	Current output (settable)
Upper limit	3.5 ... 22.5 mA
Lower limit	3.5 ... 22.5 mA
Error signal	3.5 ... 22.5 mA

2.8 Construction design

2.8.1 Dimensional picture

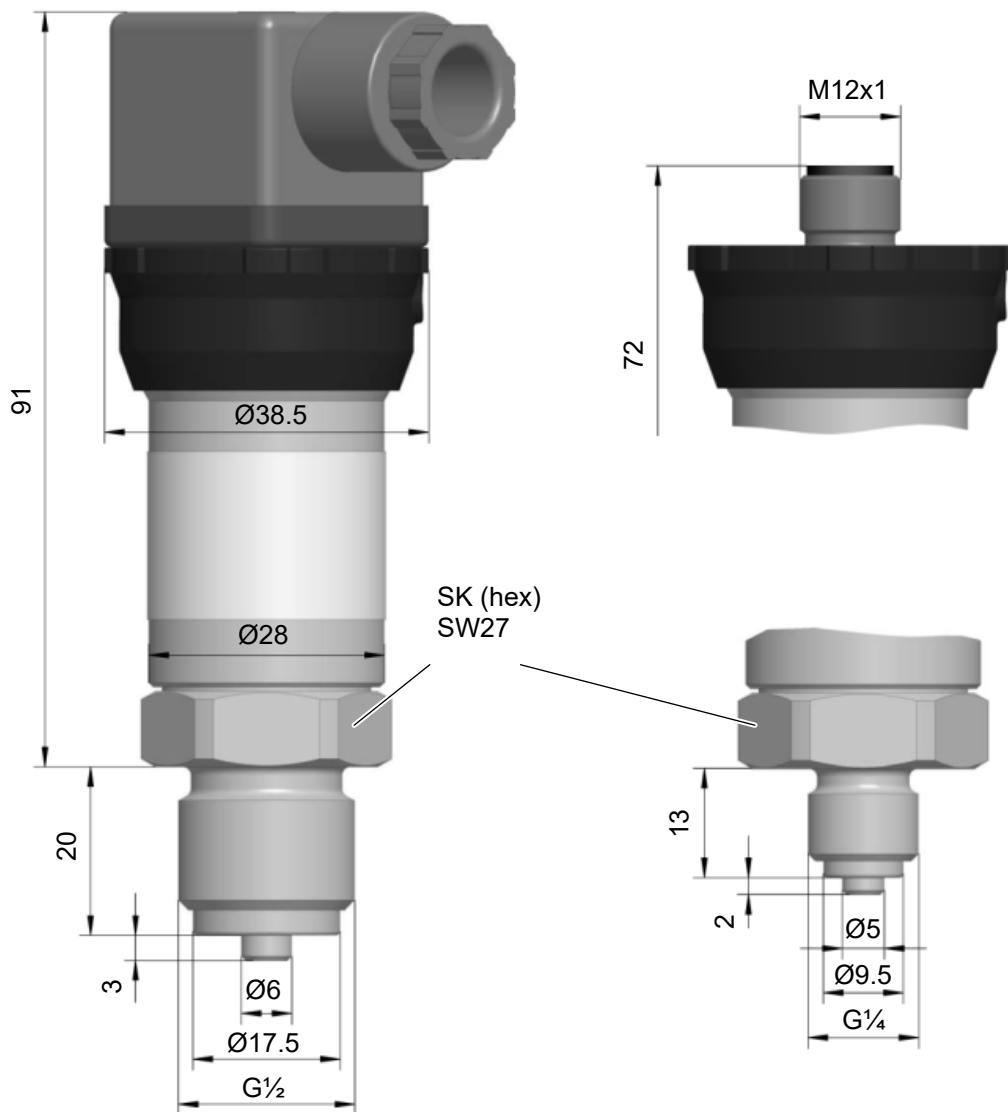

Fig. 4: Standard casing dimensional drawing

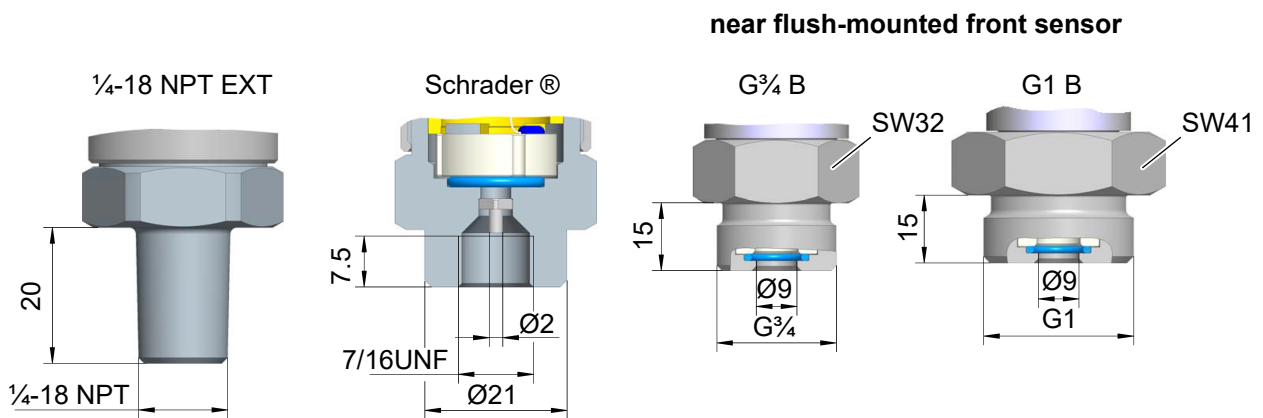

Fig. 5: Process connections dimensional drawing

2.8.2 Process connection

Port		Material
G½ B	Connection shanks with external thread	1.4404
G¼ B	Connection shanks with external thread	1.4404
¼-18 NPT EXT	Connection shanks with external thread	1.4404
7/16 UNF	Connection with inner thread for the Schrader®- screw connection >	1.4404
G¾ B	Connection shanks with external thread near flush-mounted front sensor	1.4404
G1 B	Connection shanks with external thread near flush-mounted front sensor	1.4404

2.8.3 Electrical connection

Unit connector and cable socket DIN EN 175 301-803 Form A, 4 pin

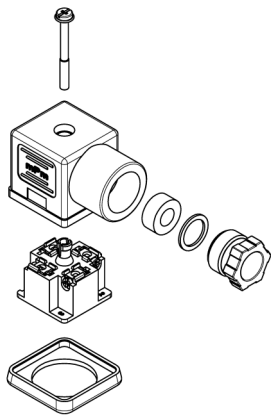
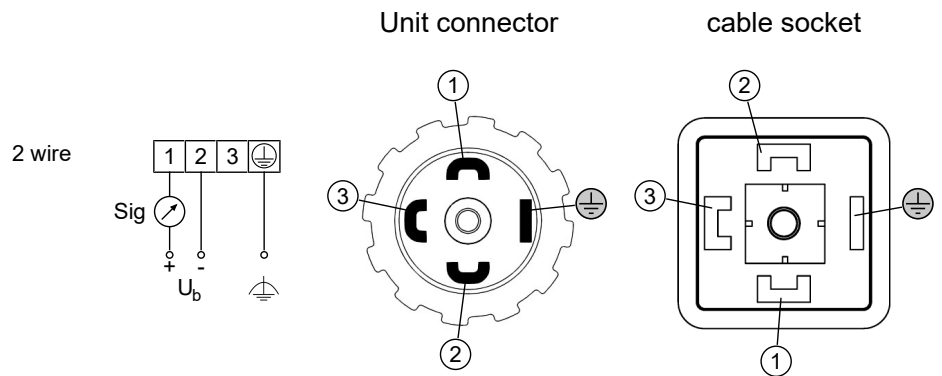

Fig. 6: Cable socket DIN EN 175 301-803A



M12 flanged connector DIN EN 61076-2-101 coding A, 5 pin

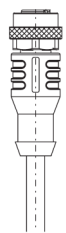
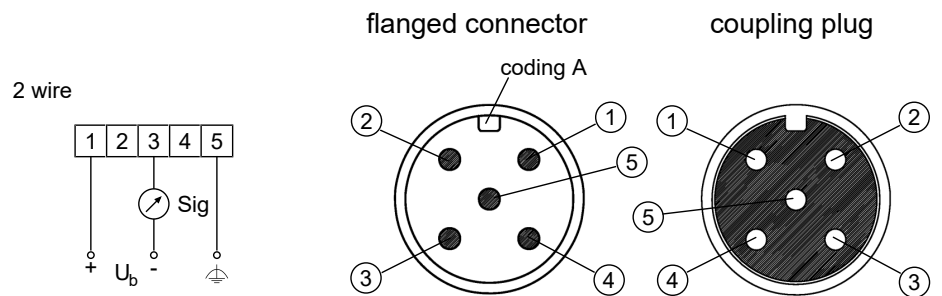
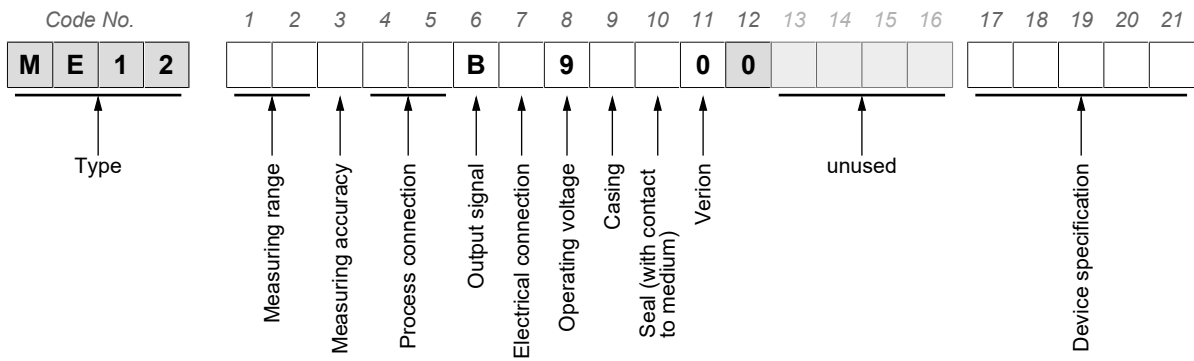

Fig. 7: M12 coupling plug DIN EN 61076-2-101



3 Order Codes



[1.2]	Measuring range	[1,2]	Messbereich	Abs.	Rel.
01	0...0.6 bar	F1	0 ... 60 kPa		•
02	0...1 bar	F2	0 ... 100 kPa	•	•
03	0...1.6 bar	F3	0 ... 160 kPa	•	•
04	0...2.5 bar	F4	0 ... 250 kPa	•	•
05	0...4 bar	F5	0 ... 400 kPa	•	•
06	0...6 bar	F6	0 ... 600 kPa	•	•
07	0...10 bar	F7	0 ... 1000 kPa	•	•
08	0...16 bar	F8	0 ... 1600 kPa	•	•
09	0...25 bar	G1	0 ... 2500 kPa		•
10	0...40 bar	G2	0 ... 4000 kPa		•
11	0...60 bar	G3	0 ... 6000 kPa		•
31	-1...0 bar				•
32	-1...0.6 bar				•
33	-1...1.5 bar				•
34	-1...3 bar				•
35	-1...5 bar				•
36	-1...9 bar				•
37	-1...15 bar				•
38	-1...24 bar				•
39	0...-1 bar				•

Abs. = Absolute pressure measurement

Rel. = relative pressure measurement.

[3]	Measurement accuracy
M	1.0 % Characteristic curve deviation during relative pressure measurement
0	0.5 % Characteristic curve deviation during relative pressure measurement
S	1.0 % characteristic curve deviation for absolute pressure measurement
T	0.5 % characteristic curve deviation for absolute pressure measurement

[4.5] Process connection		Material
85	Connection shanks with external thread G $\frac{1}{4}$ B	1.4404
87	Connection shanks with external thread G $\frac{1}{2}$ B	
88	Connecting port with outer thread $\frac{1}{4}$ -18 NPT EXT	
P1	Schrader® screw connection inner thread 7/16 UNF	
A3	Near flush-mounted front sensor outer thread G1 B	
A8	Near flush-mounted front sensor outer thread G $\frac{3}{4}$ B	

[6] Output signal		
B	4 ... 20 mA	2-wire version

[7] Electrical connection	
H	Cable socket DIN EN 175 301-803
M	M12 coupling device DIN EN 61076-2-101

[8] Operating voltage		
9	24 V DC	2-wire version

[9] Casing	Protection class (DIN EN 60 529)	
0	Standard casing	
V	Standard casing, cast version	IP65

[10] Seal (with contact to medium)		
V	FKM	Fluororubber, Viton®
C	CR	Chloroprene rubber (Neopren®)
E	EPDM	Ethylene propylene diene rubber
H	H-NBR	Hydrogenated acrylonitrile butadiene rubber
K	FFPM	Perfluorinated rubber (Kalrez®)

[11] Version	
0	Standard

[17] Device specification	
S	Dust explosion protection Zone 22; dry dusts
R	Gas explosion protection zone 2, flammable gases

[18 ... 21] Device specification	
####	Ser. no. (Customer-specific model)

3.1 Accessories

Order no.	Planned measures	No. of Poles	Length
06401993	PUR cable with M12-coupling	4-pin	2m
06401994	PUR cable with M12-coupling	4-pin	5m
06401563	PUR cable with M12-coupling	4-pin	7m
06401572	PUR cable with M12-coupling	4-pin	10m
MZ1###	Siphons		
MZ400#	Capillary throttle coil		
MZ410#	Settable damping reactor		
MZ5###	Manometer shutoff valve acc. to DIN 16270/16271		
MZ6###	Manometer shutoff valve acc. to DIN 16272		
EU03	3-wire transmitter PC Interface incl. PC software		
EU13	2-wire transmitter PC Interface incl. PC software		

A data sheet is available on our website www.fischermesstechnik.de or on request.

3.2 Information about the document

This document contains all technical data about the device. Great care was taken when compiling the texts and illustrations. nevertheless, errors cannot be ruled out.

Subject to technical amendments.

Notes

Notes

Notes



FISCHER Mess- und Regeltechnik GmbH

Bielefelder Str. 37a
D-32107 Bad Salzuflen

Tel. +49 5222 974-0

Fax +49 5222 7170

www.fischermesstechnik.de

info@fischermesstechnik.de