

EA14D || Differential Pressure Indicator

The EA14D consists of an electronic module and a pair of separated pressure transmitters. It is an intelligent multi-function instrument that measures and displays differential pressure and (optionally) transmits the measured value as a standardized 3-wire electrical signal. Its programmable limit detection functions enables it also to act as an accurate and versatile differential pressure switch.

Principles of Operation

The electronic module converts the analog signals from the pressure sensors and then digitally processes the input values. Its microcontroller provides a high degree of user programmability and tremendous versatility. The electronic module computes the pressure difference, controls the module's digital display and limit signaling on-off outputs, and (optionally) produces a new analog signal output. The readings can be filtered, scaled, inverted, or linearized through a user-defined look-up table.

The external pressure transmitters are connected to the electronic module through flexible signal cables terminated by plug-in connectors. Only the pressure transmitters supplied as part of the instrument set can be used. The pressure ratings of the pressure transmitters and the measuring range of the instrument are matched and factory calibrated and marked accordingly on the product identification label.



Features

- Large bright LED display
- Selectable pressure units
- 2 independent limits with a choice of logic modes
- Digitally programmable zero adjustment and filtering
- Optional analog signal output, with user-programmable scaling, linearization, inversion, and offset adjustment.
- User-defined signal conversion look-up table (up to 30 points)
- Fully programmable from a PC, using the optional Model EU03 PC Adaptor
- Separate display of each pressure possible

Typical Applications

- Differential pressure measurement of highly contaminated media
- Filter condition monitoring
- Hydrostatic level measurement
- Simplified pump control
- Monitoring of pumps and compressors

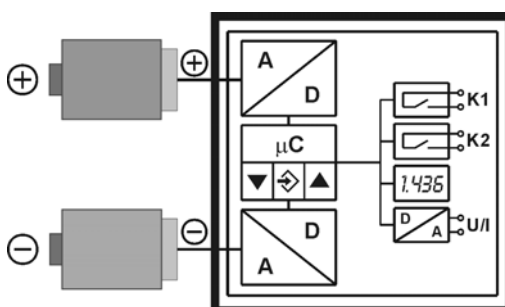

Schematic Diagram



Specifications

General

Measuring range	bar	6.0	10.0	16.0	25.0	40.0	60.0	100.0
Nominal transmitter pressure range	bar	6	10	16	25	40	60	100
Straight line error (max.)°	%FS	0.1						
Straight line error (typ.)°	%FS	<0.05						
Tc span (max.)°	%FS 10K	<0.1						
Tc span (typ.)°	%FS 10K	<0.025						
Tc zero point (max.)°	%FS 10K	<0.1						
Tc zero point (typ.)°	%FS 10K	<0.025						

Shown values characterize the electronic module only, values of the attached pressure transmitter are not included (see data sheet of pressure transmitter).

°: Straight line error = nonlinearity + hysteresis; at 25°C; pressure within specified range (characteristic linear, not spreaded)

°°: Pressure within specified range (characteristic linear, not spreaded)

Operating temp. (ambient)	-10 ... 70°C
Operating temp. (media)	See data sheet pressure transmitter
Storage temperature	-20 ... 70°C
Protection class (housing)	IP 65 per DIN EN 60529
Electrical	
Nominal supply voltage	24 V DC / AC
Operating supply voltage	12 ... 32 V DC / AC
Output signal	0 ... 20 mA, 4 ... 20 mA, or 0 ... 10 V DC (3-wire)
Output signal load	For current output $R_L \leq (U_B - 4 \text{ V}) / 0,02 \text{ A}$ ($U_B \leq 26\text{V}$), else $R_L \leq 1100 \Omega$ For voltage output $R_L \geq 2 \text{ K}\Omega$ ($U_B \geq 15 \text{ V}$), $R_L \geq 10 \text{ K}\Omega$ ($U_B = 12 \dots 15\text{V}$)
Power consumption	Approx. 2 W / VA (without external pressure transmitters)
Switching contacts	2 sets of programmable voltage free contacts: N/O or N/C $U_{\text{max}} = 32 \text{ V DC / AC}$; $I_{\text{max}} = 2 \text{ A}$; $P_{\text{max}} = 64 \text{ W / VA}$ Optional, instead of relay outputs: 2 programmable voltage free MOSFET switch outputs; NO/NC, $U = 3 \dots 32 \text{ V DC/AC}$, $I_{\text{max}} = 0,25 \text{ A}$, $P_{\text{max}} = 8 \text{ W/VA}$, $R_{\text{ON}} \leq 4 \Omega$
Display	3½ digit LED
Connections	
External transmitter supply	Supply of EA14D, fused via PTC (approx. 8 Ω)
Max. current	≤ 250 mA for the external pressure transmitter (limited by PTC)
Electrical connections	Two round-shell multi-pin connector sockets (M12, male) Connector 1: 5-pin: power input and analog signal output Connector 2: 4-pin: relay contacts / solid-state switch outputs
External pressure transmitters	Two round-shell multi-pin connector sockets (M12, female) or square-shell 4-pin connector (female), acc. to DIN EN 175 301-803-A, 1m cable
Materials, mounting	
Materials, housing	Polyamide PA6,6
Materials, media contact	See data sheet pressure transmitter
Mounting	Mounting holes at rear for panel mounting Wall mountable using adaptor plate If the instrument is intended for outdoor application, we highly recommend using an adequate protective housing (or at least a big enough shelter) as protection against UV-radiation on the membrane keyboard and against exposure of the instrument to rain or snow.

Dimensions (all units in mm unless stated otherwise)

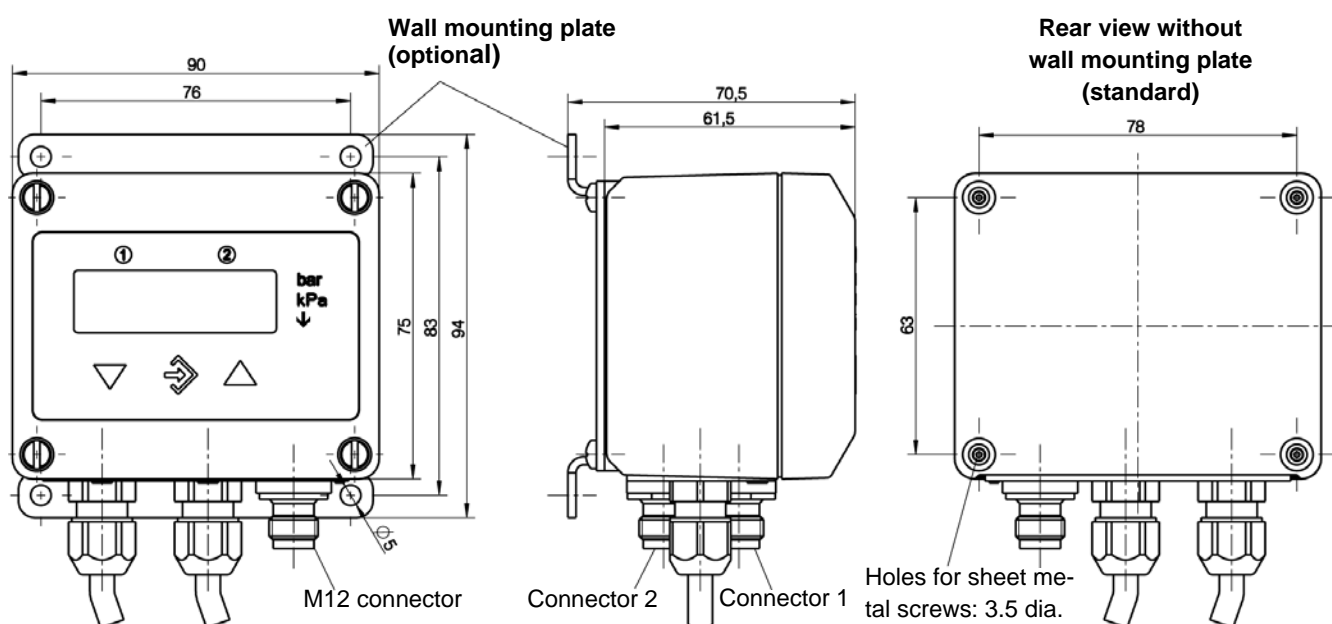

Square-shell 4-pin connector (female) acc. to DIN EN 175 301-803, 1m cable

Electrical connections

The pinning of connector 1 is also used for the M12 connector for the external pressure transmitter.

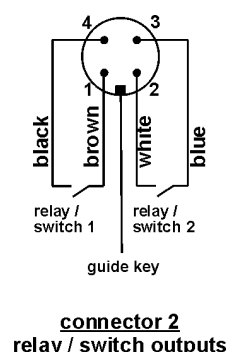
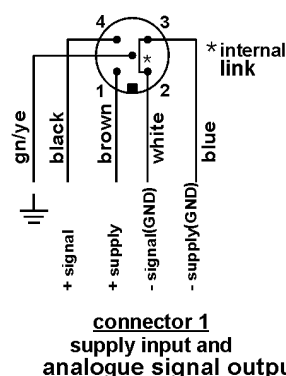
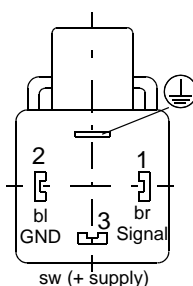
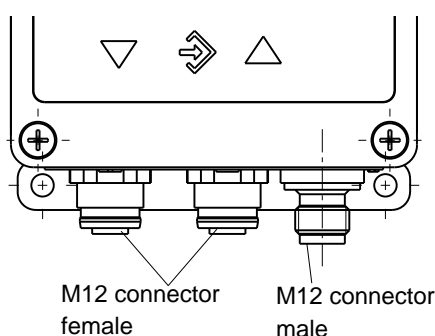

Programming

Via membrane key-switches or by using PC-programming interface (accessory).

Programming mode can be password protected.

	Settings
Offset	Cancellation of input pressure difference
Displayed pressure	P1, P2, ΔP (3)
Input filtering	0.0...100.0s (10/90% step response time) for signal output, display separated
Relay / switch 1/2	Activation point, de-activation point, response time delay (0...100 s), logic (N/O or N/C)
Measurement unit selection	bar, kPa, „free unit“ start value, end value and decimal place for „free unit“
Output signal start/end value	can be set at any point measuring range (2)
Zero suppression	0...100 counts (1)
Output characteristic	linear, square rooted, horizontal cylindr. tank, table (3...30 entries)
Password range	001 ... 999 (000 = password protection disabled)

- (1) Measured value deviations up to 100 counts, symmetric about zero, are set to zero. Used for zero drift suppression.
- (2) Maximum effective turn-down ratio = 10:1. Only the output signal is affected. Transfer function is inverted if start value > end value.
- (3) Display of P1 or P2 is for inspecting purpose only. All settings refer to ΔP .

Ordering Code

Differential Pressure Indicator

EA14

D	0						K	0		M	
---	---	--	--	--	--	--	---	---	--	---	--

Differential pressure	>	D										
Measuring range												
6.0 bar	>	0	6									
10 bar	>	0	7									
16 bar	>	0	8									
25 bar	>	0	9									
40 bar	>	1	0									
60 bar	>	1	1									
100 bar	>	1	2									
Electrical connection transmitter												
two M12 round-shell multi-pin connectors	>						M					
two Square-shell 4-pin connectors (f) acc. to DIN EN 175 301-803, 1m cable	>						H					
Signal input (only equal signals are allowed)												
0 - 20 mA linear, 3-wire	>						A					
4 - 20 mA linear, 2-wire	>						B					
0 - 10 V DC linear, 3-wire	>						C					
Signal output												
no signal output	>						0					
0 - 20 mA linear, 3-wire	>						A					
0 - 10 V DC linear, 3-wire	>						C					
4 - 20 mA linear, 3-wire	>						P					
Supply voltage												
24 V DC/AC (12-32 V DC/AC operating)	>						K					
Display and limit switching outputs												
3½ digit LED display; 2 sets of voltage free relay contacts	>									3		
3½ digit LED display; 2 solid-state switch outputs	>									6		
Electrical connection												
M12 round-shell multi-pin connector	>										M	
Mounting												
Standard (rear fastening holes)	>											0
Wall mounting	>											W

Accessories

Ordering code	Designation	Pins	Application	Length
06401993	cable with M12 connector	4-pin	for relay / switch	2 m
06401994	cable with M12 connector	4-pin	for relay / switch	5 m
06401995	cable with M12 connector	5-pin	for supply / signal	2 m
06401996	cable with M12 connector	5-pin	for supply / signal	5 m
04005144	wall mounting adapter set			
EU03.F300	PC-programming interface with SW			