



IEC 61508
IEC 61511

SIL

ISO 13849

PLd



Ex II 3G Ex ec IIC T4 Gc

Ex II 3D Ex tc IIIB T125°C Dc



RoHS III
COMPLIANT



Safety manual

DE90

Differential pressure transmitter

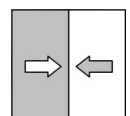

Masthead

Manufacturer:**FISCHER Mess- und Regeltechnik GmbH**Bielefelderstr. 37a
D-32107 Bad SalzuflenTelephone: +49 5222 974 0
Telefax: +49 5222 7170eMail: info@fischermesstechnik.deweb: www.fischermesstechnik.de**Technical editorial team:**

Documentation representative: T. Malischewski

Technical editor: R. Kleemann

All rights, also those to the translation, reserved. No part of this document may be reproduced or processed, duplicated or distributed using electronic systems or any other form (print, photocopy, microfilm or another process) without the written consent of the company FISCHER Mess- und Regeltechnik GmbH, Bad Salzuflen.

Reproduction for internal use is expressly allowed.

Brand names and procedures are used for information purposes only and do not take the respective patent situation into account. Great care was taken when compiling the texts and illustrations; Nevertheless, errors cannot be ruled out. The company FISCHER Mess- und Regeltechnik GmbH will not accept any legal responsibility or liability for this.

Subject to technical amendments.

© FISCHER Mess- und Regeltechnik 2020

Version history

Rev. ST4-A 03/20	Version 1 (first edition)
Rev. ST4-B 06/20	Version 2 (Change cover picture, DIN EN IEC 60079-7)
Rev. ST4-C 01/22	Version 3 (Manufacturer approval SIL/PL added)
Rev. ST4-D 01/23	Version 4 (Assembly and installation: drawings revised)
Rev. ST4-E 06/23	Version 5 Operational reliability according to IEC 61511

Table of contents

1 Scope and standards	4
2 Description of the Device and Field of Application	5
2.1 Safety function.....	5
2.1.1 Parameterization.....	5
2.1.2 Model with current output.....	6
2.1.3 Model with voltage output	7
2.1.4 Model with switch output.....	8
3 Notes on Planning	9
3.1 Intended use.....	9
3.2 Parameters	9
3.3 Functional security (IEC 61508/IEC 61511).....	9
3.3.1 Operation mode	9
3.3.2 Inspection intervals	9
3.3.3 Lifetime	9
3.3.4 Assembly and installation	10
3.3.4.1 Devices with one channel.....	10
3.3.4.2 Devices with two channels	12
3.4 Performance Level (EN ISO 13849-1)	14
3.4.1 Operation mode	14
3.4.2 Inspection intervals	14
3.4.3 Lifetime	14
3.4.4 Assembly and installation	14
3.4.4.1 Devices with one channel.....	14
3.4.4.2 Devices with two channels	16
4 Repeat tests	18
4.1 Maintenance.....	18
4.2 Function test (proof test)	18
4.2.1 Analog output.....	19
4.2.2 Switch output	20
4.2.3 Assessment	20
5 Safety-relevant variables	21
5.1 Sensor type A.....	21
5.1.1 Model with analogue output.....	21
5.1.2 Model with switch output.....	23
5.2 Sensor type B.....	25
5.2.1 Model with analogue output.....	25
5.2.2 Model with switch output.....	27
6 Attachments	29
6.1 Manufacturer's declarations SIL/PL.....	29
6.2 Glossary	33
6.3 Failure rates	36
6.4 Unit types	36

1 Scope and standards

WARNING! This Safety Manual should only be used in conjunction with the operating instructions of the respective unit. Pay attention to the safety instructions in the operating instructions.

This documentation contains information and safety instructions required for the use of the differential pressure transmitter DE90 in safety-related systems.

It is designed for persons that mount, configure and commission the device, and also for project developers and operators.

This safety manual applies for all models of the differential pressure transmitter DE90 of the series PRO-LINE® with the following restrictions.

- Firmware from version 1.12.
- Models with a Modbus interface are not allowed.
- Both channels may not be used for the same safety function.
- The safety coefficients were determined based on FMEAs. These apply under the condition that the output signals are monitored and analysed by a downstream control system.

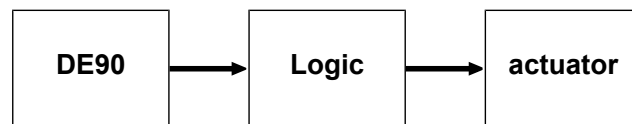

Fig. 1: Processing chain

The following norms are referenced for the calculations.

Functional security	IEC 61508: 2010 Functional safety of safety-related electrical/ electronic/programmable electronic systems
	IEC 61511: 2016 Functional safety - PLT safety devices for the process industry
Safety of Machinery	EN ISO 13849-1:2015 Safety of machinery - Safety-related parts of control systems - Part 1: General design prin- ciples
Part failure rate	SN 29500: 2010 Failure rates (Siemens)

2 Description of the Device and Field of Application

2.1 Safety function

The differential pressure transmitter transfers the input signal (pressure) into a standardised analogue output signal. Also, it can be used to monitor the limit value (overstepping or undercutting) using the switch outputs.

2.1.1 Parameterization

Analogue outputs

Depending on the version, the device has one or two analog outputs. Devices without analog output do not need to be parameterized. The outputs can be designed as current or voltage outputs. Both outputs must be parameterized as follows:

Analog output 1	Parameter	Value
	An.output 1 assignmt	channel 1
	Limit C1	Off
Analog output 2	Parameter	Value
	An.output 1 assignmt	channel 2
	Limit C2	Off
Signal limits (Channel, Channel 2)	Parameter	Value
Current output	Limit I min.	0 mA
	Limit I max.	21.5 mA
	I error signal	0 mA or 21.5 mA
Voltage output	Limit U min.	0 V
	Limit U max.	10.5 V
	U error signal	0 V or 10.5 V

Switching outputs

The device has two or four switching outputs depending on the version. Two switching outputs each must be connected in inverting fashion. Both switching outputs switch at the same limit value (SP1=SP2) or (SP3=SP4) and must be parameterised as follows.

Switching output 1	Value	Switching output 2	Value
SP1 Assignment	channel 1	SP2 assignment	channel 1
SP1 on	P _{SP}	SP2 on	P _{SP}
SP1 off	P _{SP}	SP2 off	P _{SP}
SP1 delay on	0 s	SP2 delay on	0 s
SP1 delay off	0 s	SP2 delay off	0 s
SP1 Function	Normally open	SP2 function	Normally closed
Switching output 3	Value	Switching output 4	Value
SP3 assignment	channel 2	SP4 assignment	channel 2
SP3 on	P _{SP}	SP4 on	P _{SP}
SP3 off	P _{SP}	SP4 off	P _{SP}
SP3 delay on	0 s	SP4 delay on	0 s
SP3 delay off	0 s	SP4 delay off	0 s
SP3 function	normally open	SP4 function	normally close

P_{SP}: Programmed switching point (pressure value)

2.1.2 Model with current output

The following signal is allowed for the current output:

- 4 ... 20 mA

Definition of a safe state

Single channel structure (HFT=0)

0 ... 20 mA Not allowed

4 ... 20 mA $(4 \text{ mA} - \Delta I) \leq I_{\text{out}} \leq (20 \text{ mA} + \Delta I)$

Two-channel structure (HFT=1)

Unit 1

0 ... 20 mA Not allowed

4 ... 20 mA $(4 \text{ mA} - \Delta I) \leq I_{\text{out1}} \leq (20 \text{ mA} + \Delta I)$

Unit 2

0 ... 20 mA Not allowed

4 ... 20 mA $(4 \text{ mA} - \Delta I) \leq I_{\text{out2}} \leq (20 \text{ mA} + \Delta I)$

Condition $|I_{\text{out1}} - I_{\text{out2}}| < 2 \Delta I$

The following applies to the evaluation by the safety control:

All values that meet the specified conditions can be considered correct. All other values must be considered as dangerous.

Calculation of the measurement uncertainty

The uncertainty of measurement (ΔI) is calculated from the data sheet data and the operating temperature (ϑ) using the following formula:

e_{max} [%] : Maximum measuring deviation
 TK_{Zero} [%/10K] : Maximum temperature coefficient at zero point
 TK_{Span} [%/10K] : Maximum temperature coefficient of the span

$$\Delta I = \Delta I_{\text{max}} = 16 \text{ [mA]} \cdot \left[e_{\text{max}} + (|\vartheta - 20 \text{ [}^\circ\text{C]}|) \cdot (TK_{\text{Zero}} + TK_{\text{Span}}) \right]$$

2.1.3 Model with voltage output

Two signals are permitted for the voltage output:

- 2 ... 10 V
- 1 ... 5 V

The voltage output is set to 0 ... 10 V in the factory. However, this signal cannot be used for the safety function and must be parameterized to one of the permissible signals.

Definition of the safe state

Single channel structure (HFT=0)			
0 ... 10 V	Not allowed		
		U_{\min}	U_{\max}
2 ... 10 V	$(U_{\min} - \Delta U) \leq U_{\text{out}} \leq (U_{\max} + \Delta U)$	2 V	10 V
1 ... 5 V		1 V	5 V
Two-channel structure (HFT=1)			
0 ... 10 V	Not allowed		
		U_{\min}	U_{\max}
2 ... 10 V	Gerät 1: $(U_{\min} - \Delta U) \leq U_{\text{out1}} \leq (U_{\max} + \Delta U)$	2 V	10 V
1 ... 5 V	Gerät 2: $(U_{\min} - \Delta U) \leq U_{\text{out2}} \leq (U_{\max} + \Delta U)$	1 V	5 V
Condition	$ U_{\text{out1}} - U_{\text{out2}} < 2 \Delta U$		

The following applies to the evaluation by the safety control:

All values that meet the specified conditions can be considered correct. All other values must be considered as dangerous.

Calculation of the measurement uncertainty

The uncertainty of measurement (ΔU) is calculated from the data sheet information and the operating temperature (ϑ) using the following formula:

e_{\max}	[%]	: Maximum measuring deviation
TK_{Zero}	[%/10K]	: Maximum temperature coefficient at zero point
TK_{Span}	[%/10K]	: Maximum temperature coefficient of the span
U_{\max}	[V]	: Maximum signal value of the analog output
U_{\min}	[V]	: Minimum signal value of the analog output

$$\Delta U = \Delta U_{\max} = (U_{\max} - U_{\min}) \cdot \left[e_{\max} + (|\vartheta - 20 \text{ [}^\circ\text{C]}|) \cdot (TK_{\text{Zero}} + TK_{\text{Span}}) \right]$$

2.1.4 Model with switch output

Definition of the safe state

The operator has to decide whether, from the point of view of the installation, an undercut or an overcut is considered safe. The states of the switching outputs can be assumed to be correct as long as they differ from one another.

Single channel structure (HFT=0)		
Two switching outputs	Undercut	Exceed
	SP1 = 0 and SP2 = 1	SP1 = 1 and SP2 = 0
Four switching outputs		
	SP1 = 0 and SP2 = 1	SP1 = 1 and SP2 = 0
	SP3 = 0 and SP4 = 1	SP3 = 1 and SP4 = 0
Two-channel structure (HFT=1)		
Unit 1	Undercut	Exceed
Two switching outputs	SP1 = 0 and SP2 = 1	SP1 = 1 and SP2 = 0
Four switching outputs	SP1 = 0 and SP2 = 1	SP1 = 1 and SP2 = 0
	SP3 = 0 and SP4 = 1	SP3 = 1 and SP4 = 0
Device 2	Undercut	Exceed
Two switching outputs	SP1 = 0 and SP2 = 1	SP1 = 1 and SP2 = 0
Four switching outputs	SP1 = 0 and SP2 = 1	SP1 = 1 and SP2 = 0
	SP3 = 0 and SP4 = 1	SP3 = 1 and SP4 = 0

1: low impedance (through-switched) switching output

0: high-impedance (blocked) switching output

3 Notes on Planning

3.1 Intended use

The device can be used as part of a safety function to monitor differential pressure.

In the corresponding version, the device can be used in areas at risk of explosion Zone 2 and 22.

3.2 Parameters



⚠ WARNING

Parameter change

The device is configured in the factory before delivery. Only the operator of the system or personnel he names and briefs may carry out the configuration work.

The set default limits for the output signal may not be changed.

The parameterization can be changed in two ways.⁽¹⁾

- By keyboard input on the device
- By remote parameterization via transmitter PC interface

Please also note the specifications in the section Parameterization [▶ 9].

3.3 Functional security (IEC 61508/IEC 61511)

3.3.1 Operation mode

The unit is used with a low demand rate operating mode. The demand rate is less than once a year and no more than twice the frequency of the repeat test. The associated reference variable is the PFD value.

3.3.2 Inspection intervals

A Proof Test must be carried out after commissioning and then, at the latest, after the end of the defined test interval.

The tables in the section Safety performance indicators [▶ 21] state the mean probability of a malfunction in the requirement case depending on the test interval and the system architecture.

3.3.3 Lifetime

The lifetime starting from the production date is 10 years.

If the lifetime is exceeded, the error rates can gradually increase due to wear and aging, and the calculated PFD values can no longer be used. In worst cases, this leads to a loss of the SIL classification.

⁽¹⁾Please observe the information in the operating instructions.

3.3.4 Assembly and installation

Please also observe the installation instructions in the operating manual.

NOTICE! Note that the evaluation and monitoring of the signals must be carried out by the downstream safety control (SRP/CS). In the event of a deviation, the safe state must be assumed.

The following legend applies to the following connection diagrams:

Legend

- i_m connecting equipment
- c Cross check
- I1, I2 Differential pressure transmitter (DE90)
- L1...L4 Logic
- m Monitoring
- O1...O4 Output units
- OUT1...OUT4 Output (DE90)
- SF1, SF2 Safety function 1, Safety function 2

3.3.4.1 Devices with one channel

3.3.4.1.1 Architecture 1oo1 (HFT=0)

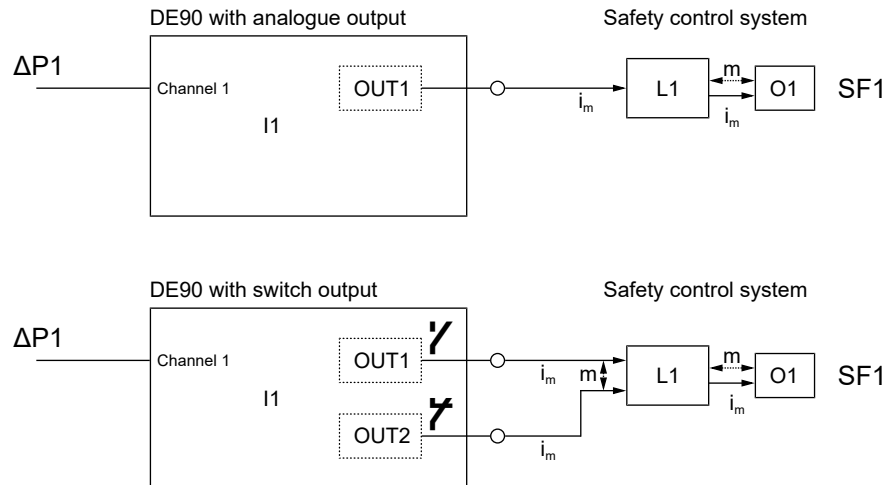

3.3.4.1.2 Architektur 1oo2 (HFT=1)

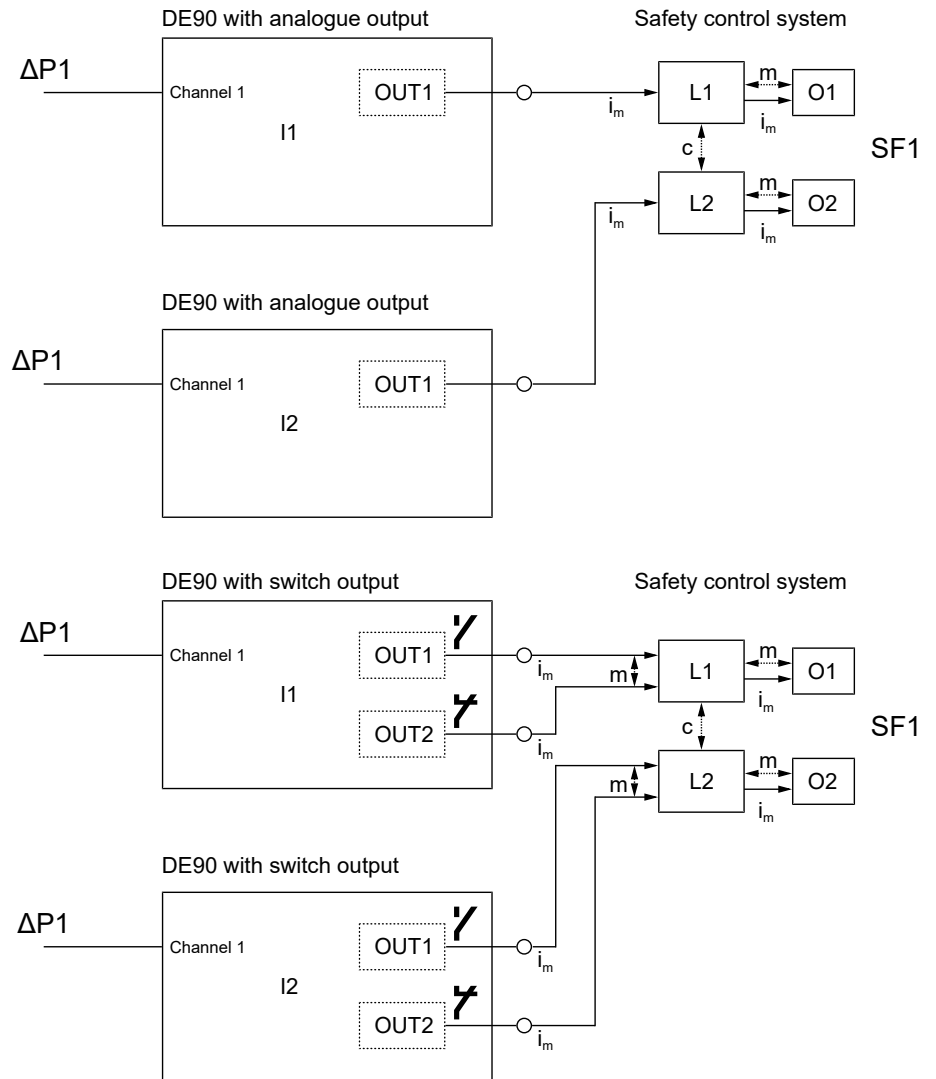

3.3.4.2 Devices with two channels

3.3.4.2.1 Architecture 1oo1 (HFT=0)

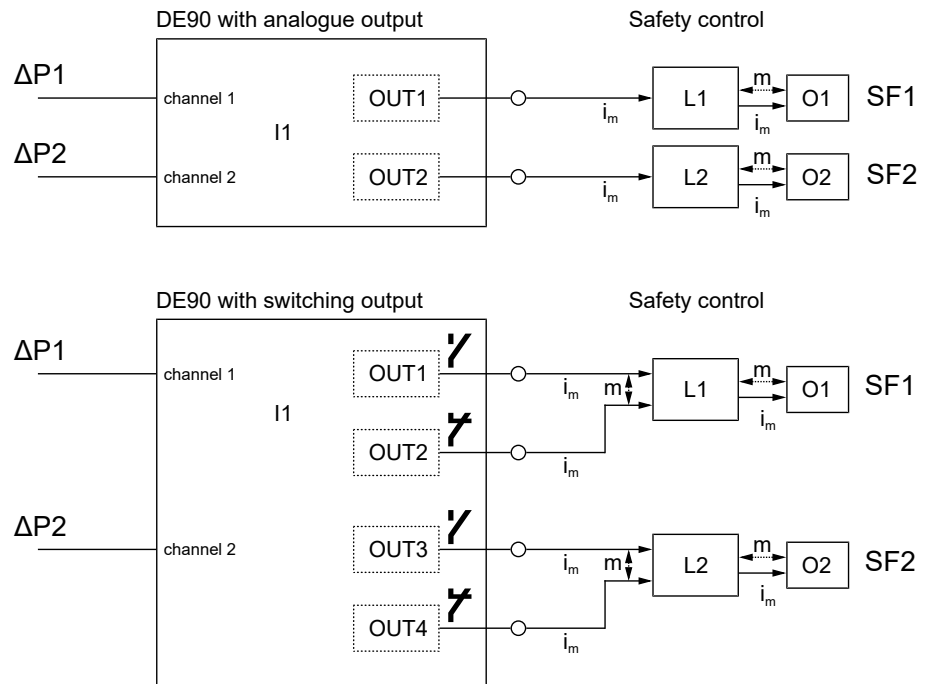

3.3.4.2.2 Architecture 1oo2 (HFT=1)

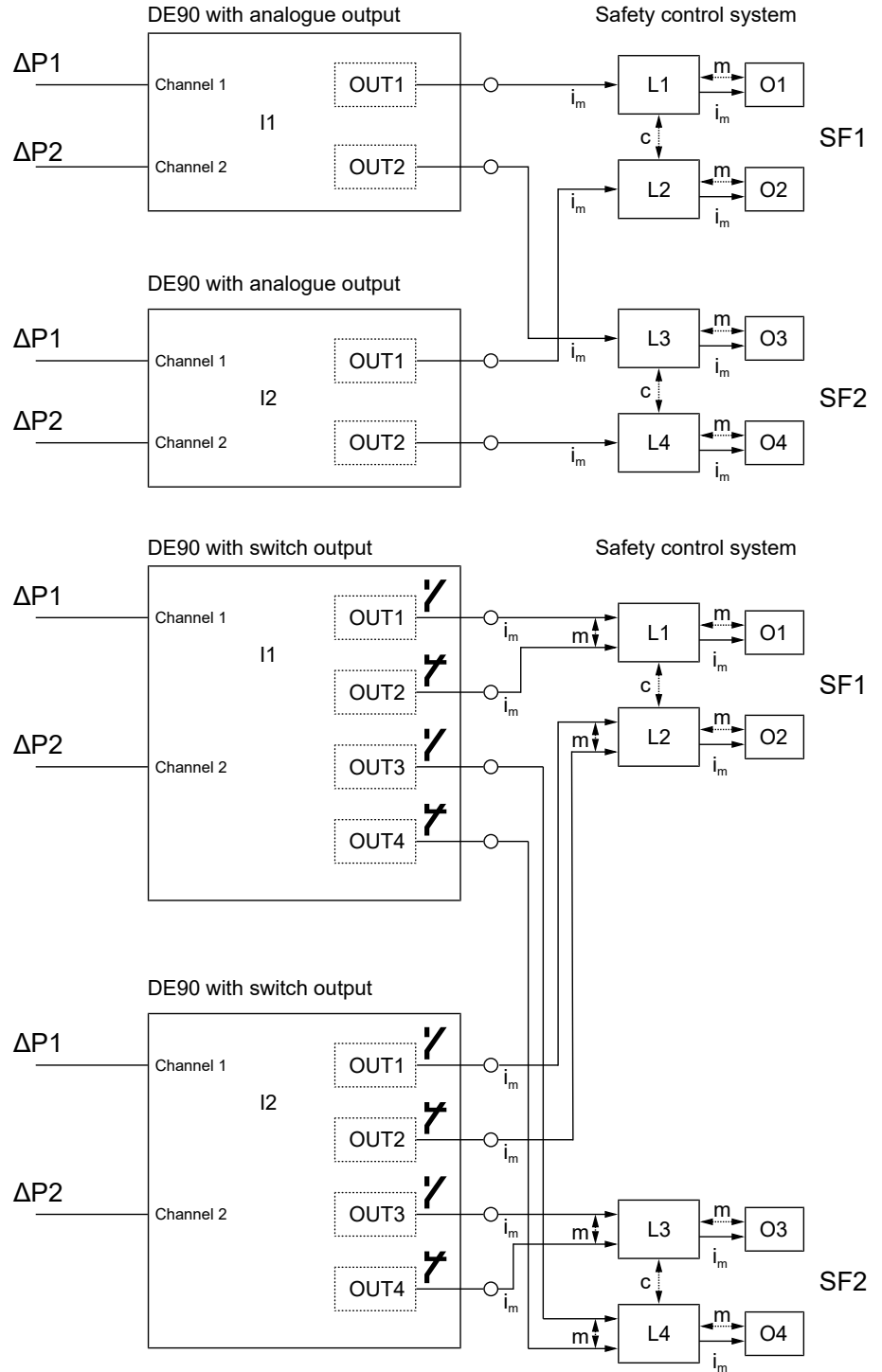

3.4 Performance Level (EN ISO 13849-1)

3.4.1 Operation mode

The unit is used with a high demand rate operating mode. Maximum one requirement per year allowed.

3.4.2 Inspection intervals

Conduct a proof test after commissioning and then after 5 years at the latest.

3.4.3 Lifetime

The lifetime starting from the production date is 20 years.

If the lifetime is exceeded, the error rates can gradually increase due to wear and aging.

3.4.4 Assembly and installation

Please also observe the installation instructions in the operating manual.

NOTICE! Please note that the evaluation and monitoring of the signals must be carried out by the downstream safety controller (SRP/CS). If there is a deviation, the safe state must be assumed.

The following legend applies to the following connection diagrams:

Legend

- i_m connecting equipment
- c Cross check
- I1, I2 Differential pressure transmitter (DE90)
- L1...L4 Logic
- m Monitoring
- O1...O4 Output units
- OUT1...OUT4 Output (DE90)
- SF1, SF2 Safety function 1, Safety function 2

3.4.4.1 Devices with one channel

3.4.4.1.1 Category 1

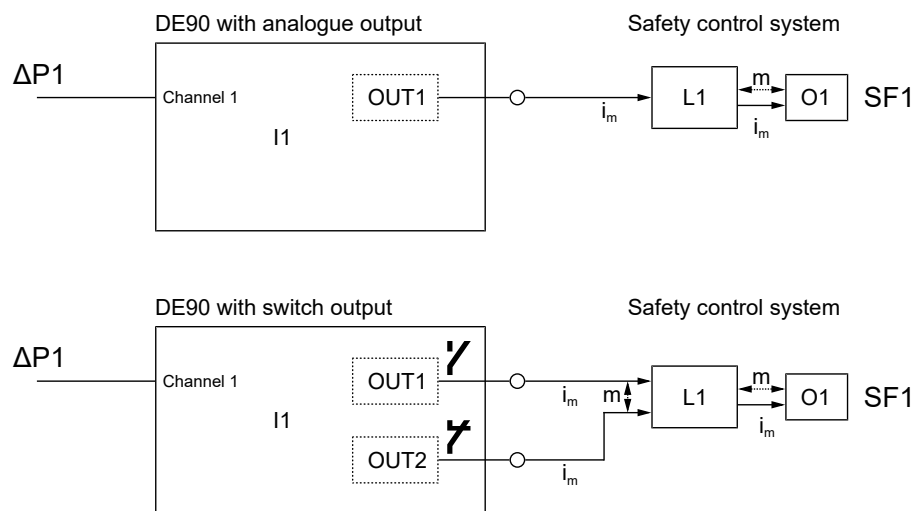

3.4.4.1.2 Category 3

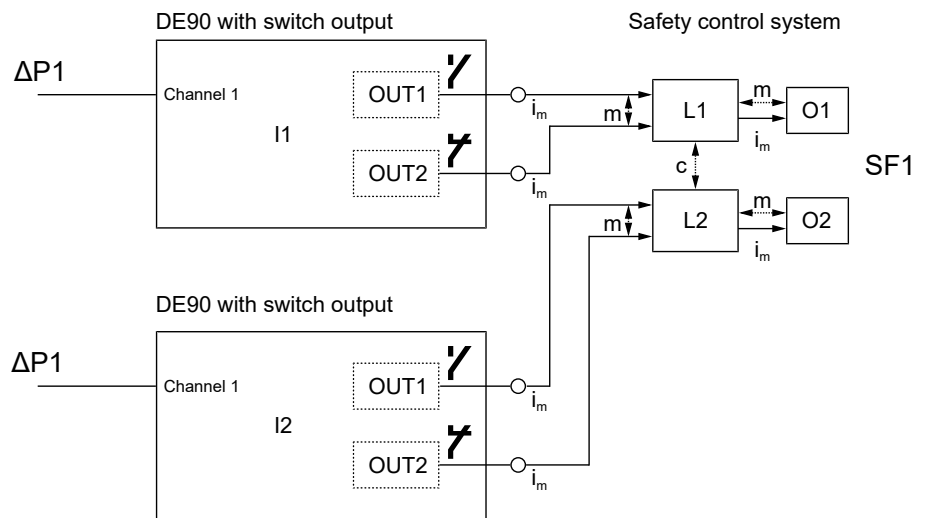
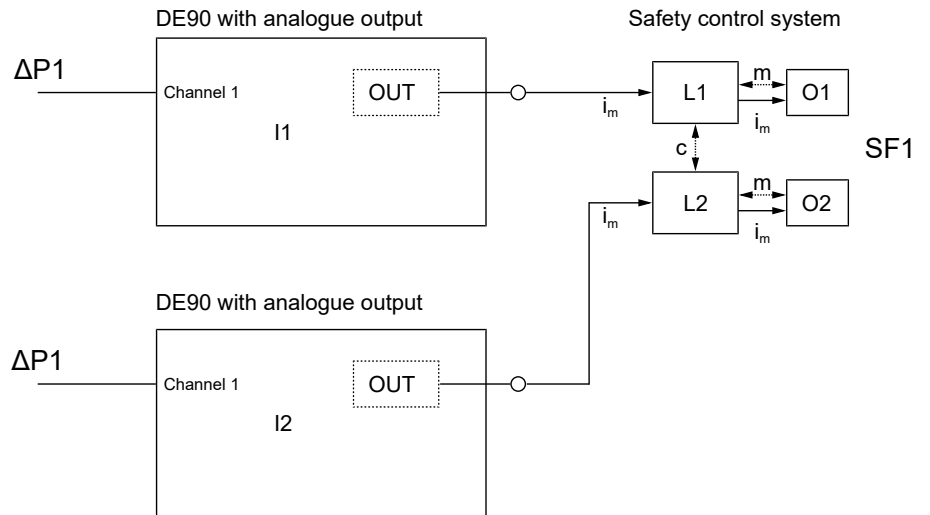

3.4.4.2 Devices with two channels

3.4.4.2.1 Category 1

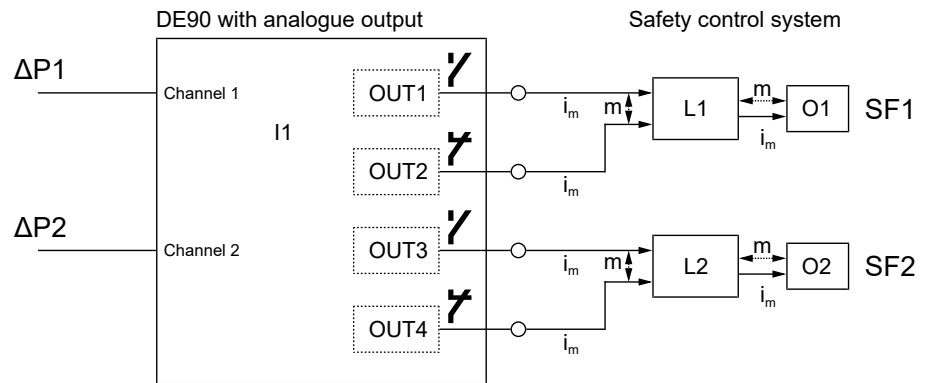
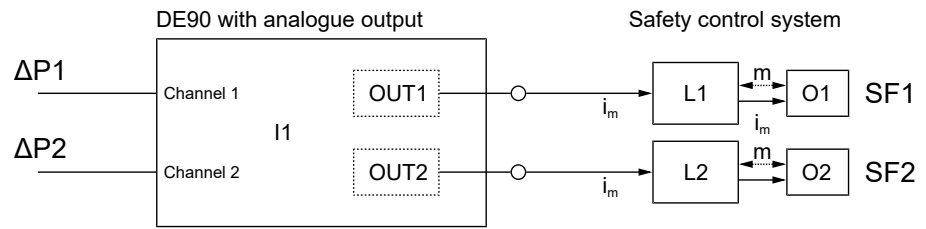

3.4.4.2.2 Category 3

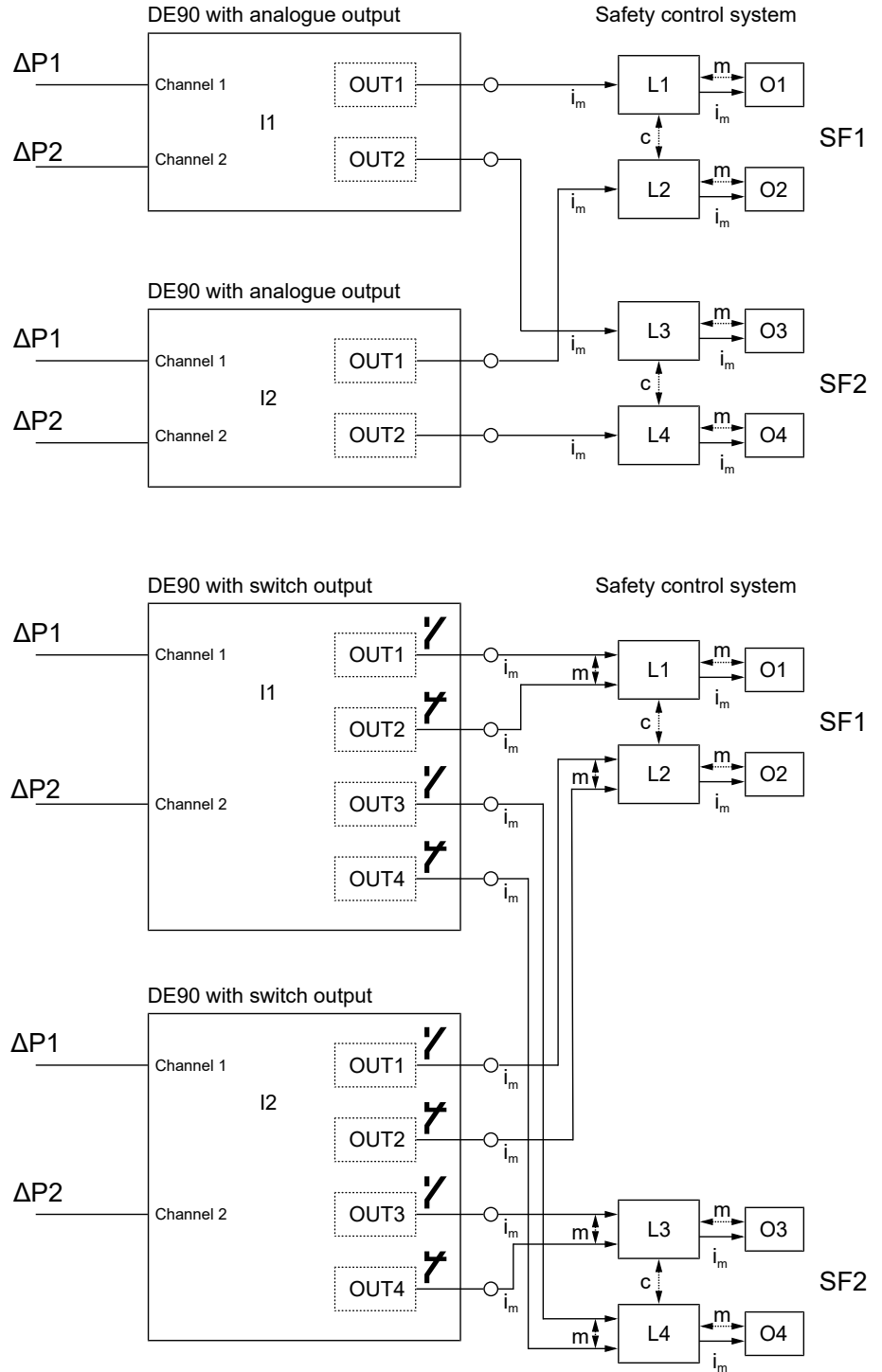

4 Repeat tests

4.1 Maintenance

Proof tests are an integral part of the safety concept to detect dangerous failures. The proof test checks the following aspects of a safety-critical component:

- Functionality
- do the components satisfy the prevailing application conditions
- are the interfaces to other components OK

All critical parts need to be tested with the proof test. Spot checks are sufficient for parts that are not critical for safety.

4.2 Function test (proof test)

NOTICE! The EMC and environmental conditions must correspond to the tested levels of the EMC Directive 2014/30/EU.

The determination of the proof-test procedure for the entire safety engineering system is the responsibility of the operator.

The following functional test must be carried out for the DE90 safety component.

1. Checking the functionality for input values within the measuring range
2. Checking the switching points

If possible, the test pressure should be generated by the Safety Engineering System (SIS) itself. In this case, it can be checked at the same time whether the signals are correctly processed by the higher-level safety control system and forwarded via the actuator.

Otherwise the DE90 must be removed and connected as follows. Please note that some versions do not have an analogue output.

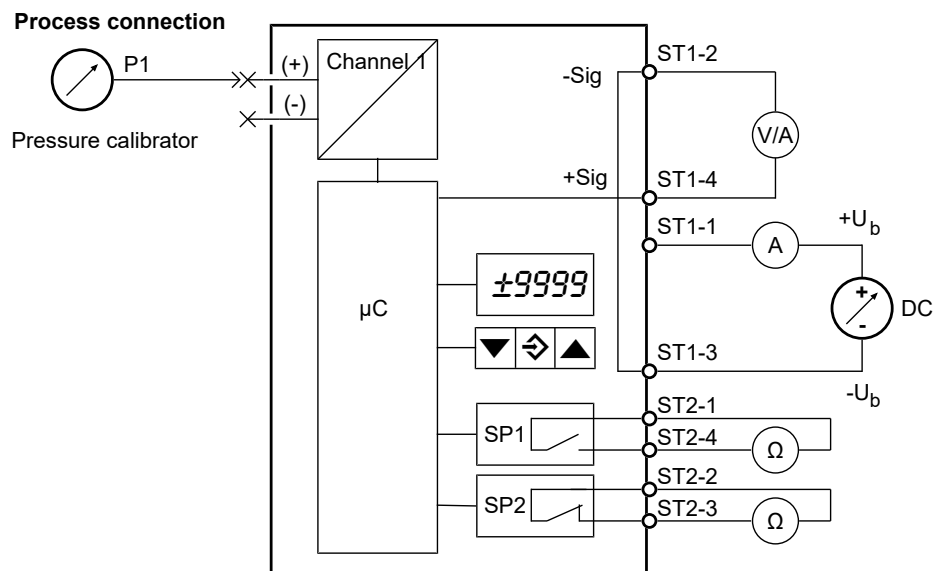

Fig. 2: Functional test

4.2.1 Analog output

- Set an operating voltage within the range of the permissible operating voltage.
- Check the power consumption. The power consumption must not exceed the value specified in the data sheet.
- The calculation of the measurement uncertainty ΔI or ΔU can be found in
 - Version with Current output [▶ 6] resp.
 - Ausführung mit Voltage output [▶ 7].

Input values within the measuring range

1. Use the pressure calibrator to set an input signal that corresponds to the beginning of the measuring range.
2. Check the output signal using a multimeter.
 - When using a voltage signal, the value must be within $U_{\min} \pm \Delta U$.
 - If the current signal is used, the value must be within $4\text{mA} \pm \Delta I$.
3. Use the pressure calibrator to set an input signal that corresponds to the end of the measuring range.
4. Check the output signal using a multimeter.
 - When using a voltage signal, the value must be within $U_{\max} \pm \Delta U$.
 - If the current signal is used, the value must be within $20\text{mA} \pm \Delta I$.
5. Repeat these steps for each measuring channel.

Input values outside the measuring range

1. Use the pressure calibrator to set an input signal that is well below the beginning of the measuring range.
2. Check the output signal using a multimeter.
 - When using a voltage signal, the value must be below $U_{\min} - \Delta U$.
 - If the current signal is used, the value must be below $4\text{mA} - \Delta I$.
3. Use the pressure calibrator to set an input signal that is well above the end of the measuring range.
4. Check the output signal using a multimeter.
 - When using a voltage signal, the value must be above $U_{\max} + \Delta U$.
 - If the current signal is used, the value must be within $20\text{mA} + \Delta I$.
5. Repeat these steps for each measuring channel.

Checking the error signal in the SIS

1. Connect the analogue output of the DE90 electrically to the higher level safety controller.
2. Use the pressure calibrator to set an input signal that is well below the start of the measuring range so that an error signal is generated.
3. Check whether the faulty signal is detected by the safety controller.

4.2.2 Switch output

- Set an operating voltage within the range of the permissible operating voltage.
- Check the power consumption. The power consumption must not exceed the value specified in the data sheet.
- When evaluating the switching states, it must be noted whether the defined switching points are monitored if they are exceeded or not. The correct switching states can be found in the section Device description/Model with switch output [► 8].

Check behaviour of the adjusted switching point.

P_{SP} is the parameterized switching point

ΔMB_{max} corresponds to the (basic) measuring deviation according to the data sheet.

1. Use the pressure calibrator to set the input signal to $P < P_{SP} - \Delta MB_{max}$. Check the states of the switching outputs. The contacts must not switch (initial state).
2. Use the pressure calibrator to set the input signal to $P > P_{SP} + \Delta MB_{max}$ (passing the switching point). Check the states of the switching outputs. The contacts must now have switched.
3. Use the pressure calibrator to set the input signal to $P < P_{SP} - \Delta MB_{max}$. Check the states of the switching outputs. The contacts must now have switched back to their original state.

Checking the error signal in the SIS

1. Connect the two switching outputs of the device electrically to the higher-level safety controller.
2. Use the pressure calibrator to set an input signal that is clearly below the set switching point. Check the states of the switching outputs. The contacts must not switch (output state). Check whether the change in state of the device is detected by the safety controller.
3. Now change the input signal during operation so that it is clearly above the set switching point (passing the switching point). Check the states of the switching outputs. The contacts must now have switched. Check whether the change of state of the device is detected by the safety controller.
4. Use the pressure calibrator to set an input signal that is clearly below the set switching point. Check the states of the switching outputs. The contacts must now have switched back to their original state. Check whether the change in state of the device is detected by the safety controller.

4.2.3 Assessment

If the device does not pass one of the stated steps, the function test is failed and the device must be replaced immediately.

5 Safety-relevant variables

NOTICE! The safety performance indicators do not apply for devices with a Modbus.

The safety-related performance indicators depend on the sensors used (Type A or Type B) for the respective pressure range. For this reason, the performance indicators are sorted according to sensor type and pressure range. The performance indicators apply per channel.

5.1 Sensor type A

5.1.1 Model with analogue output

Code no.	1	2	3	4	5	6	7	8	9	10	11	12	13	14	15	16		
	D	E	9	0	x ₁	x ₂	#	#	x ₃	0	x ₄	0	0	0	#	#	#	#

Standard

Characteristic		Value range
Channel 1	x1	51, 97, 98, A4, A5, L0, D1, D2, D3, D4, D5, D6, L4, L5, R6, 2L, L7, R7
Channel 2	x2	00, 51, 97, 98, A4, A5, L0, D1, D2, D3, D4, D5, D6, L4, L5, R6, 2L, L7, R7
Analogue output	x3	C, A, P
Special aspects	x4	0

Increased overload and burst pressure resistance

Characteristic		Value range
Channel 1	x1	52, 53, 54, A6, A7, A8, A9, D7, D8, N1, L6, R1, R2, L8, D9
Channel 2	x2	00, 52, 53, 54, A6, A7, A8, A9, D7, D8, N1, L6, R1, R2, L8, D9
Analogue output	x3	C, A, P
Special aspects	x4	1

Safety coefficients

λ_s	142.3 Fit	Safe failure rate
λ_d	2046.6 Fit	Dangerous failure rate
λ_{dd}	1291.8 Fit	Dangerous detected failure rate
λ_{du}	754.8 Fit	Dangerous undetected failure rate

SIL (IEC 61508 / IEC 61511)

device type	Type B	Complex device
Operating mode	Low Demand	Requirement max. 1/year

1oo1 architecture

HFT	0	Hardware fault tolerance
SFF	65.5 %	Safe failure fraction

The probability of a failure on demand (PFD) depends on the test interval.

Proof-Test interval	1 year	2 years	5 years	10 years
PFD	$3.3 \cdot 10^{-3}$	$6.6 \cdot 10^{-3}$	$1.7 \cdot 10^{-2}$	$3.3 \cdot 10^{-2}$
IEC 61508	SIL1	SIL1	SIL1	SIL1
IEC 61511	SIL2	SIL2	SIL2	SIL2

1oo2 architecture

β	10%	Probability that the same error occurs at the same time in both channels.
β_d	5%	Probability of the same dangerous fault occurring at the same time in both channels.
MRT	8 h	Mean repair time
MTTR	8 h	Mean time to repair
HFT	1	Hardware fault tolerance
SFF	65.5 %	Safe failure fraction

The probability of a failure on demand (PFD) depends on the test interval.

Proof-Test interval	1 year	2 years	5 years	10 years
PFD	$3.5 \cdot 10^{-4}$	$7.1 \cdot 10^{-4}$	$2.0 \cdot 10^{-3}$	$4.6 \cdot 10^{-3}$
IEC 61508	SIL2	SIL2	SIL2	SIL2

PL (DIN EN ISO 13849)

Device type	Type B	Complex device	
Operating mode	High Demand	Requirement max. 1/year	
MTTF _d	55.8 years	high	Mean time to dangerous failure
DC	63.1 %	low	Diagnostic coverage factor
Achievable performance level		PL	
Category 1		c	
Category 3		d	

5.1.2 Model with switch output

Code no.				1	2	3	4	5	6	7	8	9	10	11	12	13	14	15	16
D	E	9	0	x ₁	x ₂	#	#	x ₃	0	x ₄	0	0	0	#	#	#	#		

Standard

Characteristic		Value range
Channel 1	x1	51, 97, 98, A4, A5, L0, D1, D2, D3, D4, D5, D6, L4, L5, R6, 2L, L7, R7
Channel 2	x2	00, 51, 97, 98, A4, A5, L0, D1, D2, D3, D4, D5, D6, L4, L5, R6, 2L, L7, R7
Analogue output	x3	0
Special aspects	x4	0

Increased overload and burst pressure resistance

Characteristic		Value range
Channel 1	x1	52, 53, 54, A6, A7, A8, A9, D7, D8, N1, L6, R1, R2, L8, D9
Channel 2	x2	00, 52, 53, 54, A6, A7, A8, A9, D7, D8, N1, L6, R1, R2, L8, D9
Analogue output	x3	0
Special aspects	x4	1

Safety coefficients

λ_s	177.2 Fit	Safe failure rate
λ_d	2402.9 Fit	Dangerous failure rate
λ_{dd}	1741.3 Fit	Dangerous detected failure rate
λ_{du}	661.7 Fit	Dangerous undetected failure rate

SIL (IEC 61508 / IEC 61511)

Devise type	Type B	Complex device
Operation mode	Low Demand	Requirement max. 1/year

1oo1 architecture

HFT	0	Hardware fault tolerance
SFF	74.4 %	Safe failur fraction

The probability of a failure on demand (PFD) depends on the test interval.

Proof-Test interval	1 year	2 years	5 years	10 years
PFD	$2.9 \cdot 10^{-3}$	$5.8 \cdot 10^{-3}$	$1.5 \cdot 10^{-2}$	$2.9 \cdot 10^{-2}$
IEC 61508	SIL1	SIL1	SIL1	SIL1
IEC 61511	SIL2	SIL2	SIL2	SIL2

1oo2 architecture

β	10%	Probability that the same error occurs at the same time in both channels.
β_d	5%	Probability of the same dangerous fault occurring at the same time in both channels.
MRT	8 h	Mean repair time
MTTR	8 h	Mean time to repair
HFT	1	Hardware fault tolerance
SFF	74.4 %	Safe failure fraction

The probability of a failure on demand (PFD) depends on the test interval.

Proof-Test interval	1 year	2 years	5 years	10 years
PFD	$3.0 \cdot 10^{-4}$	$6.2 \cdot 10^{-4}$	$1.7 \cdot 10^{-3}$	$3.9 \cdot 10^{-3}$
IEC61508	SIL2	SIL2	SIL2	SIL2

PL (DIN EN ISO 13849)

Device type	Type B	Complex device	
Operating mode	High Demand	Requirement max. 1/year	
MTTF _d	47.5 years	high	Mean time to dangerous failure
DC	72.5 %	low	Diagnostic coverage factor
Achievable performance level		PL	
Category 1		c	
Category 3		d	

5.2 Sensor type B

5.2.1 Model with analogue output

Code No.	1	2	3	4	5	6	7	8	9	10	11	12	13	14	15	16		
	D	E	9	0	x ₁	x ₂	#	#	x ₃	0	x ₄	0	0	0	#	#	#	#

Characteristic	Value range
Channel 1	x1 52, 53, 54, 55, 56, 57, 58, 59, 60, 82, A6, A7, A8, A9, B1, B2, C5, B3, B4, R5, B6, D7, D8, N1, N2, N3, N4, N5, E5, E6, E7, L6, R1, R2, L8, L9, M6, M7, M8, R8, R9, T1, D9, E1, E2, E3, E4, 1P, 2P, 3P
Channel 2	x2 00, 52, 53, 54, 55, 56, 57, 58, 59, 60, 82, A6, A7, A8, A9, B1, B2, C5, B3, B4, R5, B6, D7, D8, N1, N2, N3, N4, N5, E5, E6, E7, L6, R1, R2, L8, L9, M6, M7, M8, R8, R9, T1, D9, E1, E2, E3, E4, 1P, 2P, 3P
Analogue output	x3 C, A, P
Special aspects	x4 0

Safety coefficients		
λ_s	142.3 Fit	Safe failure rate
λ_d	992.6 Fit	Dangerous failure rate
λ_{dd}	614.2 Fit	Dangerous detected failure rate
λ_{du}	378.3 Fit	Dangerous undetected failure rate

SIL (IEC 61508 /IEC 61511)	Device type	Type B	Complex device
	Operating mode	Low Demand	Requirement max. 1/year

1oo1 architecture

HFT	0	Hardware fault tolerance
SFF	66.7 %	Safe failure fraction

The probability of a failure on demand (PFD) depends on the test interval.

Proof-Test interval	1 year	2 years	5 years	10 years
PFD	$1.7 \cdot 10^{-3}$	$3.3 \cdot 10^{-3}$	$8.3 \cdot 10^{-3}$	$1.7 \cdot 10^{-2}$
IEC 61508	SIL1	SIL1	SIL1	SIL1
IEC 61511	SIL2	SIL2	SIL2	SIL2

1oo2 architecture

β	10%	Probability that the same error occurs at the same time in both channels.
β_d	5%	Probability of the same dangerous fault occurring at the same time in both channels.
MRT	8 h	Mean repair time
MTTR	8 h	Mean time to repair
HFT	1	Hardware fault tolerance
SFF	66.7 %	Safe failure fraction

The probability of a failure on demand (PFD) depends on the test interval.

Proof-Test interval	1 year	2 years	5 years	10 years
PFD	$1.7 \cdot 10^{-4}$	$3.5 \cdot 10^{-4}$	$9.1 \cdot 10^{-4}$	$2.0 \cdot 10^{-3}$
IEC 61508	SIL2	SIL2	SIL2	SIL2

PL (DIN EN ISO 13849)

Device type	Type B	Complex device	
Operating mode	High Demand	Requirement max. 1/year	
MTTF _d	115 years	high	Mean time to dangerous failure
DC	61.9 %	niedrig	Diagnostic coverage factor
Achievable performance level		PL	
Category 1		c	
Category 3		d	

5.2.2 Model with switch output

Code No.				1	2	3	4	5	6	7	8	9	10	11	12	13	14	15	16
D	E	9	0	x ₁	x ₂	#	#	x ₃	0	x ₄	0	0	0	#	#	#	#		

Characteristic		Value range
Channel 1	x1	52, 55, 56, 57, 58, 59, 60, 82, A6, A7, B1, C5, B2, B3, B4, R5, B6, D7, N2, N3, N4, N5, E5, E6, E7, R1, L6, L9, M6, M7, R8, R9, T1
Channel 2	x2	00, 52, 55, 56, 57, 58, 59, 60, 82, A6, A7, B1, C5, B2, B3, B4, R5, B6, D7, N2, N3, N4, N5, E5, E6, E7, R1, L6, L9, M6, M7, R8, R9, T1
Analogue output	x3	0
Special aspects	x4	0

Safety coefficients		
λ_s	177.2 Fit	Safe failure rate
λ_d	1348.9 Fit	Dangerous failure rate
λ_{dd}	1038.6 Fit	Dangerous detected failure rate
λ_{du}	310.3 Fit	Dangerous undetected failure rate

SIL (DIN EN 61508)

Device type	Type B	Complex device
Operating mode	Low Demand	Requirement max. 1/year

1oo1 architecture

HFT	0	Hardware fault tolerance
SFF	79.7 %	Safe failure fraction

The probability of a failure on demand (PFD) depends on the test interval.

Proof-Test interval	1 year	2 years	5 years	10 years
PFD	$1.4 \cdot 10^{-3}$	$2.7 \cdot 10^{-3}$	$6.8 \cdot 10^{-3}$	$1.4 \cdot 10^{-2}$
IEC 61508	SIL1	SIL1	SIL1	SIL1
IEC 61511	SIL2	SIL2	SIL2	SIL2

1oo2 architecture

β	10%	Probability that the same error occurs at the same time in both channels.
β_d	5%	Probability of the same dangerous fault occurring at the same time in both channels.
MRT	8 h	Mean repair time
MTTR	8 h	Mean time to repair
HFT	1	Hardware fault tolerance
SFF	79.7 %	Safe failure fraction

The probability of a failure on demand (PFD) depends on the test interval.

Proof-Test interval	1 year	2 years	5 years	10 years
PFD	$1.4 \cdot 10^{-4}$	$2.8 \cdot 10^{-4}$	$7.4 \cdot 10^{-4}$	$1.6 \cdot 10^{-3}$
IEC 61508	SIL2	SIL2	SIL2	SIL2

PL (DIN EN ISO 13849)

Device type	Type B	Complex device	
Operating mode	High Demand	Requirement max. 1/year	
MTTF _d	84.6 years	high	Mean time to dangerous failure
DC	77 %	niedrig	Diagnostic coverage factor
Achievable performance level		PL	
Category 1		c	
Category 3		d	

6 Attachments

6.1 Manufacturer's declarations SIL/PL



(Translation)

Manufacturer's declaration

The manufacturer

FISCHER Mess- und Regeltechnik GmbH
 Bielefelder Str. 37a
 D-32107 Bad Salzuffen
 Tel.+49 5222 974-0
 Fax:+49 5222 7170
 www.fischermesstechnik.de

hereby declares for the units of the series described below:

Product designation **Differential pressure transmitter
 DE90 with sensor type A and analog output**

Type designations:

D	E	9	0	x₁	x₂	#	#	x₃	0	x₄	0	0	0	#	#	#	#		
Standard (x _i =0)										Increased overload (x _i =1)									
x1	51, 97, 98, A4, A5, L0, D1, D2, D3, D4, D5, D6, L4, L5, R6, 2L, L7, R7										x1	52, 53, 54, A6, A7, A8, A9, D7, D8, N1, L6, R1, R2, L8, D9							
x2	00, 51, 97, 98, A4, A5, L0, D1, D2, D3, D4, D5, D6, L4, L5, R6, 2L, L7, R7										x2	00, 52, 53, 54, A6, A7, A8, A9, D7, D8, N1, L6, R1, R2, L8, D9							
x3	C, A, P										x3	C, A, P							
x4	0										x4	1							

The following safety-related key figures apply to these units:

λ _s	142.3 FIT	Legend:
λ _d	2046.6 FIT	FIT:= Failure rate related to the time interval 10 ⁹ hours (1 FIT = 1*10 ⁻⁹ /h)
λ _{td}	1291.8 FIT	T1:= Test interval
λ _{du}	754.8 FIT	

SIL	IEC 61508		IEC 61511	PL	ISO 13849	
Architecture	1oo1	1oo2	1oo1		MTTFd	55.8 Years
HFT	0	1	0		DC	63.1 %
up to SIL	1	2	2		Category	c
SFF	65.5 %	65,5 %	65.5 %		up to PL	d
PFd (T1=1 Year)	3.3 * 10 ⁻³	3.5 * 10 ⁻⁴	3.3 * 10 ⁻³			
PFd (T1=2 Years)	6.6 * 10 ⁻³	7.1 * 10 ⁻⁴	6.6 * 10 ⁻³			
PFd (T1=5 Years)	1.7 * 10 ⁻²	2.0 * 10 ⁻³	1.7 * 10 ⁻²			
PFd (T1=10 Years)	3.3 * 10 ⁻²	4.6 * 10 ⁻³	3.3 * 10 ⁻²			

Due to these safety values and the operational safety, the unit can be used according to IEC 61508 up to SIL 1, according to IEC 61511 up to SIL2 and according to IEC 13849 up to PLd. According to IEC 61508, IEC 61511 or ISO 13849, the correct function of the safety function must be proven. The necessary key figures, safety instructions, installation and maintenance instructions can be found in the safety manual.

Bad Salzuffen
 01 June 2023

T. Malischewski
 General Manager R&D



Fig. 3: HE_EN_DE90_SIL-PL_AA



(Translation)

Manufacturer's declaration

The manufacturer

FISCHER Mess- und Regeltechnik GmbH
 Bielefelder Str. 37a
 D-32107 Bad Salzufen
 Tel.+49 5222 974-0
 Fax+49 5222 7170
 www.fischermesstechnik.de

hereby declares for the units of the series described below:

Product designation **Differential pressure transmitter
 DE90 with sensor type A and switching output**

Type designations:

D	E	9	0	x₁	x₂	#	#	x₃	0	x₄	0	0	0	#	#	#	#		
Standard (x _i =0)									Increased overload (x _i =1)										
x1	51, 97, 98, A4, A5, L0, D1, D2, D3, D4, D5, D6, L4, L5, R6, 2L, L7, R7									x1	52, 53, 54, A6, A7, A8, A9, D7, D8, N1, L6, R1, R2, L8, D9								
x2	00, 51, 97, 98, A4, A5, L0, D1, D2, D3, D4, D5, D6, L4, L5, R6, 2L, L7, R7									x2	00, 52, 53, 54, A6, A7, A8, A9, D7, D8, N1, L6, R1, R2, L8, D9								
x3	0									x3	0								
x4	0									x4	1								

The following safety-related key figures apply to these units:

λ_s	177.2 FIT		Legend:
λ_d	2402.9 FIT		FIT:= Failure rate related to the time interval 10 ⁹ hours (1 FIT = 1*10 ⁻⁹ /h)
λ_{da}	1741,3 FIT		T1:= test interval
λ_{du}	661.7 FIT		

SIL	IEC 61508		IEC 61511	PL	ISO 13849	
	1oo1	1oo2	1oo1		MTTFd	47.5 Years
HFT	0	1	0		DC	72.5 %
up to SIL	1	2	2		Category	c
SFF	74.4 %	74.4 %	74.4 %		up to PL	d
PFD (T1=1 Year)	2.9 * 10 ⁻³	3.0 * 10 ⁻⁴	2.9 * 10 ⁻³			
PFD (T1=2 Years)	5.8 * 10 ⁻³	6.2 * 10 ⁻⁴	5.8 * 10 ⁻³			
PFD (T1=5 Years)	1.5 * 10 ⁻²	1.7 * 10 ⁻³	1.5 * 10 ⁻²			
PFD (T1=10 Years)	2.9 * 10 ⁻²	3.9 * 10 ⁻³	2.9 * 10 ⁻²			

Due to these safety values and the operational safety, the unit can be used according to IEC 61508 up to SIL 1, according to IEC 61511 up to SIL2 and according to IEC 13849 up to PLd. According to IEC 61508, IEC 61511 or ISO 13849, the correct function of the safety function must be proven. The necessary key figures, safety instructions, installation and maintenance instructions can be found in the safety manual.

ppa. T. Malischewski

Bad Salzufen
01 June 2023

T. Malischewski
 General Manager R&D



Fig. 4: HE_EN_DE90_SIL_PL_AS



(Translation)

Manufacturer's declaration

The manufacturer

FISCHER Mess- und Regeltechnik GmbH
 Bielefelder Str. 37a
 D-32107 Bad Salzufflen
 Tel.+49 5222 974-0
 Fax+49 5222 7170
 www.fischermesstechnik.de

hereby declares for the units of the series described below:

Product designation **Differential pressure transmitter
 DE90 with sensor type B and analog output**

Type designations:

	D	E	9	0	x ₁	x ₂	#	#	x ₃	0	x ₄	0	0	0	#	#	#	#	
	<i>Standard (x_i=0)</i>																		
x1	52, 53, 54, 55, 56, 57, 58, 59, 60, 82, A6, A7, A8, A9, B1, B2, C5, B3, B4, R5, B6, D7, D8, N1, N2, N3, N4, N5, E5, E6, E7, L6, R1, R2, L8, L9, M6, M7, M8, R8, R9, T1, D9, E1, E2, E3, E4, 1P, 2P, 3P																		
x2	00, 52, 53, 54, 55, 56, 57, 58, 59, 60, 82, A6, A7, A8, A9, B1, B2, C5, B3, B4, R5, B6, D7, D8, N1, N2, N3, N4, N5, E5, E6, E7, L6, R1, R2, L8, L9, M6, M7, M8, R8, R9, T1, D9, E1, E2, E3, E4, 1P, 2P, 3P																		
x3	C, A, P																		
x4	0																		

The following safety-related key figures apply to these units:

λ_s	142.3 FIT		Legend:
λ_d	992.6 FIT		<i>FIT:= Failure rate related to the time interval 10⁹ hours (1 FIT = 1*10⁻⁹/h)</i>
λ_{dd}	614.2 FIT		<i>T1:= test interval</i>
λ_{du}	378.3 FIT		

SIL		IEC 61508		IEC 61511	PL	ISO 13849	
		1oo1	1oo2	1oo1		MTTFd	115 Jahre
	HFT	0	1	0		DC	61.9 %
	up to SIL	1	2	2		Category	c
	SFF	66.7 %	66.7 %	66.7 %		up to PL	d
	PFD (T1=1 year)	1.7 * 10 ⁻³	1.7 * 10 ⁻⁴	1.7 * 10 ⁻³			
	PFD (T1=2 years)	3.3 * 10 ⁻³	3.5 * 10 ⁻⁴	3.3 * 10 ⁻³			
	PFD (T1=5 years)	8.3 * 10 ⁻³	9.1 * 10 ⁻⁴	8.3 * 10 ⁻³			
	PFD (T1=10 years)	1.7 * 10 ⁻²	2.0 * 10 ⁻³	1.7 * 10 ⁻²			

Due to these safety values and the operational safety, the unit can be used according to IEC 61508 up to SIL 1, according to IEC 61511 up to SIL2 and according to IEC 13849 up to PLd. According to IEC 61508, IEC 61511 or ISO 13849, the correct function of the safety function must be proven. The necessary key figures, safety instructions, installation and maintenance instructions can be found in the safety manual.

Bad Salzufflen
01 June 2023

T. Malischewski
 General Manager R&D



Fig. 5: HE_EN_DE90_SIL_PL_BA



(Translation)

Manufacturer's declaration

The manufacturer

FISCHER Mess- und Regeltechnik GmbH
 Bielefelder Str. 37a
 D-32107 Bad Salzuffen
 Tel.+49 5222 974-0
 Fax:+49 5222 7170
 www.fischermesstechnik.de

hereby declares for the units of the series described below:

Produktbezeichnung **Differential pressure transmitter
 DE90 with sensor type B and switching output**

Type designations:

	D	E	9	0	x ₁	x ₂	#	#	x ₃	0	x ₄	0	0	0	#	#	#	#
	Standard (x _i =0)																	
x1	52, 53, 54, 55, 56, 57, 58, 59, 60, 82, A6, A7, A8, A9, B1, B2, C5, B3, B4, R5, B6, D7, D8, N1, N2, N3, N4, N5, E5, E6, E7, L6, R1, R2, L8, L9, M6, M7, M8, R8, R9, T1, D9, E1, E2, E3, E4, 1P, 2P, 3P																	
x2	00, 52, 53, 54, 55, 56, 57, 58, 59, 60, 82, A6, A7, A8, A9, B1, B2, C5, B3, B4, R5, B6, D7, D8, N1, N2, N3, N4, N5, E5, E6, E7, L6, R1, R2, L8, L9, M6, M7, M8, R8, R9, T1, D9, E1, E2, E3, E4, 1P, 2P, 3P																	
x3	0																	
x4	0																	

The following safety-related key figures apply to these units:

λ _s	177.2 FIT		Legend:
λ _d	1348.9 FIT		FIT:= Failure rate related to the time interval 10 ⁹ hours (1 FIT = 1*10 ⁻⁹ /h)
λ _{test}	1038.6 FIT		T1:= test interval
λ _{av}	310.3 FIT		

SIL	IEC 61508		IEC 61511	PL	ISO 13849	
	1001	1002	1001		MTTFd	84.6 years
HFT	0	1	0		DC	77 %
up to SIL	1	2	2		Category	c
SFF	79.7 %	79.7 %	79.7 %		up to PL	d
PFD (T1=1 year)	1.4 * 10 ⁻³	1.4 * 10 ⁻⁴	1.4 * 10 ⁻³			
PFD (T1=2 years)	2.7 * 10 ⁻³	2.8 * 10 ⁻⁴	2.7 * 10 ⁻³			
PFD (T1=5 years)	6.8 * 10 ⁻³	7.4 * 10 ⁻⁴	6.8 * 10 ⁻³			
PFD (T1=10 years)	1.1 * 10 ⁻²	1.6 * 10 ⁻³	1.1 * 10 ⁻²			

Due to these safety values and the operational safety, the unit can be used according to IEC 61508 up to SIL 1, according to IEC 61511 up to SIL2 and according to IEC 13849 up to PLd. According to IEC 61508, IEC 61511 or ISO 13849, the correct function of the safety function must be proven. The necessary key figures, safety instructions, installation and maintenance instructions can be found in the safety manual.

ppa. T. Malischewski

Bad Salzuffen
 01 June 2023

T. Malischewski
 General Manager R&D

09010639 • HE_EN_DE90_SIL-PL_BS • Rev. ST4-B • 06/23

1 / 1



Fig. 6: HE_EN_DE90_SIL_PL_BS

6.2 Glossary

Fig. (↓^A/_Z)

Definition

β

(en) **Common Cause Factor**
(de) Beta-Faktor

Proportionality factor between the CCF rate (failure due to a common cause) and the dangerous failure rate of the individual channel.

DC

(en) **Diagnostic Coverage Factor**
(de) Diagnosedeckungsgrad

The DC parameter shows the ratio of the number of detected dangerous failures (λ_{DD}) to the total number of dangerous failures (λ_D) an.

$$DC = \frac{\sum \text{Known dangerous error}}{\sum \text{Total dangerous error}} = \frac{\sum \lambda_{DD}}{\sum \lambda_D}$$

FIT

(en) **Failure in Time**
(de) Ausfälle pro Zeit

Failure rate with respect to the time interval 10^9 hours.

$$1 \text{ FIT} = 1 \times 10^{-9} \frac{1}{h}$$

FMEDA

(en) **Failure Mode Effect and Diagnostic Analysis**
(de) Gefährdung und Risikoanalyse

Procedure to determine causes of failures and their impact on the system.

HDM

(en) **High Demand Mode**
(de) Betriebsart mit hoher Anforderungsstufe

Operating mode with high or continuous demand on the safety function. The demand rate to the safety system is greater than once annually.

HFT

(en) **Hardware Fault Tolerance**
(de) Hardware-Fehlertoleranz

The hardware fault tolerance states how many dangerous failures are possible due to the architecture without endangering the execution of the safety function.

- HFT = 0
The occurrence of a dangerous failure will lead to a failure of the safety function.
- HFT = 1
Only the occurrence of two dangerous failures will lead to a failure of the safety function.

LDM

(en) **Low Demand Mode**
(de) Betriebsart mit niedriger Anforderungsstufe

The safety function will only be carried out on demand to bring the system into a defined safe state. The frequency of requirements does not exceed one a year.

MooN	<p><i>(en)</i> Architecture with M out of N channels <i>(de)</i> Systemarchitektur mit M aus N Kanälen</p>
	<p>System architecture MooN with the variables M and N: Classification and description of safety-related systems with regard to redundancy and applied selection procedures.</p> <ul style="list-style-type: none"> • N - is the total number of redundant channels of a safety-related architecture and/or safety circuit. • M - determines the number of channels that must operate correctly to carry out the safety function.
MTBF	<p><i>(en)</i> Mean Time Between Failures <i>(de)</i> Mittlere Brauchbarkeitsdauer</p>
	<p>Mean operating duration between two failures.</p>
MTTF_d	<p><i>(en)</i> Mean Time To Dangerous Failures <i>(de)</i> Mittlere Zeit bis zum gefahrbringenden Ausfall</p>
	<p>Operating duration up to a dangerous fault.</p>
MRT	<p><i>(en)</i> Mean Repair Time <i>(de)</i> Mittlere Reparaturdauer</p>
	<p>Mean time for the repair.</p>
MTTR	<p><i>(en)</i> Mean Time To Repair <i>(de)</i> Mittlere Instandsetzungszeit</p>
	<p>Average time between the occurrence of a failure and restoration of the system.</p>
PFD	<p><i>(en)</i> Probability of Failure on Demand <i>(de)</i> Wahrscheinlichkeit einer Fehlfunktion im Anforderungsfall</p>
	<p>Probability of a dangerous failure on demand of the safety function for an operating mode with a low demand rate.</p>
PFH	<p><i>(en)</i> Probability of a dangerous Failure per Hour <i>(de)</i> Ausfallwahrscheinlichkeit pro Stunde für die Sicherheitsfunktion</p>
	<p>Frequency of a dangerous failure of the safety function for an operating mode with a high or continuous demand rate (high demand).</p>

PFS	<p>(en) Probability of Failure Spurious (de) Ausfallwahrscheinlichkeit aufgrund einer nicht beabsichtigten Prozessabschaltung</p>
<p>Frequency of failure due to a false alarm that leads to an unintentional process shutdown by the safety system. The smaller the value, the higher the system availability.</p>	
SC	<p>(en) systematic capability (de) systematische Eignung</p>
<p>Measure of confidence (expressed on a scale of SC 1 to SC 4) that an item's systematic safety integrity meets the requirements of the stated SIL for the designated item safety function when the item is specified in accordance with the compliant item safety manual for the item instructions is applied.</p>	
SFF	<p>(en) Safe Failure Fraction (de) Anteil der ungefährlichen Ausfälle</p>
<p>Resulting from the rate of safe errors plus the diagnosed or detected errors in relation to the system's total failure rate.⁽²⁾</p>	
SIF	<p>(en) Safety Instrumented Function (de) Sicherheitstechnische Funktion</p>
<p>The safety function (SIF) is a protective measure that is only activated in the event of an incident to prevent injuries, damage and pollution.</p>	
SIL	<p>(en) Safety Integrity Level (de) Sicherheits-Integritätslevel</p>
<p>One of four discrete levels to assess the requirements relating to the reliability of the safety functions in safety systems. SIL 4 is the highest and SIL 1 the lowest safety integrity level. Each level corresponds to a probability range for the failure of a safety function.</p>	
SIS	<p>(en) Safety Instrumented System (de) Sicherheitstechnisches-System</p>
<p>Safety system for performance of one or several safety functions. A system of this kind comprises at least a sensor, an overriding safety control system and an actuator.</p>	
T₁	<p>(en) Proof Test Interval (de) Prüfintervall</p>
<p>The safety system must always be in a state that guarantees the defined safety integrity. The proof test is carried out to confirm this. The test interval states the intervals in which a proof test needs to be carried out to guarantee the safety function.</p>	

⁽²⁾ Due to the lack of diagnosis and negligible number of errors in mechanical components, the method can only be used to a limited extent for valves, drives and other mechanical components. It is therefore the responsibility of the end user to ensure an appropriate SFF through suitable diagnostic measures and intrinsically safe construction.

6.3 Failure rates

The error rates differ in principle as follows:

1. Safe failures
2. Dangerous failures
3. No effect failure

The first two types of errors are further divided into detectable and undetectable errors.

The failure without effect and the safe failures, whether detected or undetected, have no influence on the safety function. On the other hand, dangerous errors lead to a dangerous state of the system. The following diagram provides an overview.

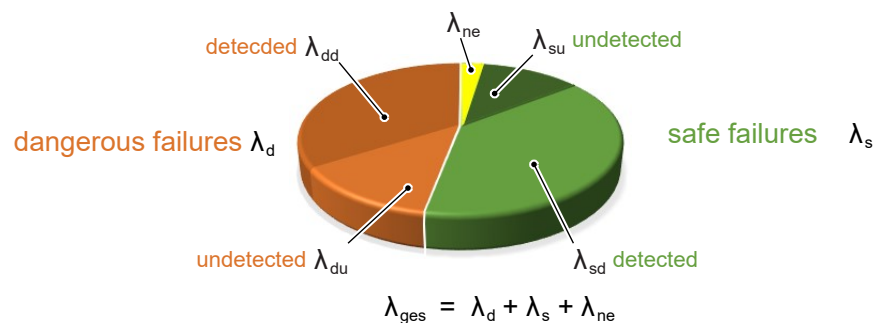

Fig. 7: Failure rates

λ_d	Dangerous failure rate
λ_{dd}	Dangerous detected failure rate
λ_{du}	Dangerous undetected failure rate
λ_s	Safe failure rate
λ_{sd}	Safe detected failure rate
λ_{su}	Safe undetected failure rate
λ_{ne}	No effect failure rate

6.4 Unit types

Type A

Simple operating equipment

Type A units are 'simple' units for which the failure behaviour of all parts used and the behaviour under failure conditions is completely known.

This includes e.g. relays, resistors and transistors, however no complex electronic parts, e.g. microcontrollers.

Type B

Complex operating equipment

Type B units are 'complex' units for which the failure behaviour of all parts used and the behaviour under failure conditions is not completely known.

These units contain electronic parts such as microcontrollers, microprocessors or ASICs. In these parts and, in particular for software-controlled functions, it is difficult to fully determine all failures.

Notes

Notes

Notes



FISCHER Mess- und Regeltechnik GmbH

Bielefelder Str. 37a
D-32107 Bad Salzuflen

Tel. +49 5222 974-0

Fax +49 5222 7170

www.fischermesstechnik.de

info@fischermesstechnik.de