



Measurement technology to record cost-intensive process factors

**Energy
Management**

- ▲ Collect and analyse energy consumption
- ▲ Reduced energy costs

SITUATION AND OUTLOOK

Increasing energy costs and the global promotion of reduction of the CO₂ emissions are issues that place increasing demands on building industrial systems.

The reduction of energy consumption is possible in a variety of means and ways. So-called “energy management” has been created as a term. This includes the planning and operation of energy generation units.

The political framework

Alongside the legal aspects which might specify limit values for emissions in industrial operations for example, political components for encouraging energy savings are gaining more importance.

The term “energy management” and the associated aspects are precisely defined in connection with this. These issues are reflected by the norm, DIN EN 16001, which serves the purpose of developing operational energy management.



OBSERVATION OF ENERGY CONSUMPTION

“Energy management” should put a company in a position to be able to continually improve its energetic performance with a systematic approach. The first step is usually an energy flow analysis which records the observation range in the operation or system. The consumption amounts are then detected. This can include analysis of load profiles that measure the individual consumption types.

This includes the factors entering the process such as electricity, water, compressed air, heat and cold among others. However, it can also include process flows that leave the pro-

cess unused in the form of waste air, waste heat or waste water. Alongside the sequences in the processes, the secondary circuits play an important role in energy management. These circuits provide the processes with energy, such as through heat transmission mediums, thermal oil, steam or hot water. Volume flows and process parameters such as pressure and temperature, to control the operating parameters on heat exchangers and pumps for example, also belong to the factors detected.



CONTROLLED FLOW RATE MONITORING

in the building technology

The energy management is gaining significance in the optimisation of air flow. The ventilators are optimally controlled with the use of frequency converters. Only the air volume actually required is produced. The optimisation and reduction of circulation volumes allow ventilation systems to be designed smaller and lead to lower electricity consumption. Alongside the temperature and the

operating pressure, volume flows are also important process factors. These can be calculated using a Venturi pipe, pitot tube probe or sensor grids using the differential pressure. Temperature compensation of signals is offered for temperature fluctuations.

MEASURING AND MONITORING FUNCTIONS

in process technology and media supply

One of the steps toward resource saving production processes is increasingly governed by the Industry 4.0 issue. Intensified networking of production processes and the display of consumption values of the media used in this conjunction help to cut costs.



FD39
Volume flow transmitter for robust applications



EA15
Digital panel indicator with touch-LCD

Application examples for energy efficiency increase according to measurement points

Measurement point	Target	Measurement parameters
Filter monitoring	Reduce pressure losses	Differential pressure pre-run and return
Steam boiler monitoring	Reduce primary energy (oil and gas), increase effect level	Temperature pre-run and return
Compressed air system	Reduce pressure losses	Flow monitoring
Cooling water systems	Improve heat insulation, reduce pressure losses, reduce waste water amounts	Pressure, differential pressure, temperature and flow
Thermal oil systems	Monitor pump protection, ageing, process heat exchanger	Volume flow
Ventilation technology	Minimisation of electricity consumption on the ventilation systems	Volume flow regulation using the frequency converter
Pump monitoring	Regulation of the heating pump	Suction and pressure side pump pressure
Storage tanks	Sufficient storage, optimal tank cycles	Continual measurement processes (capacitive, hydrostatic, bubbling method), limit value monitoring (proximity switches, conductive measurement)
Compensation tanks	Avoid system standstill	Limit level monitoring

Small figures – big effect

The following table establishes how big the savings potential is by reducing the leaks.

Comment: leaks are a “round the clock” threat 24 hours a day – even when production isn’t running!

Hole diameter (mm)	Air loss at 6 bar (l/s)	Air loss at 12 bar (l/s)	Energy loss* at 6 bar (kW/h)	Energy loss* at 12 bar (kW/h)	Costs of 6 bar (Euro/year)	Costs of 12 bar (Euro/year)
1	1.2	1.8	0.3	1.0	263	876
3	11.1	20.8	3.1	12.7	2,716	11,125
5	30.9	58.5	8.6	33.7	7,534	29,521

* = kW x 0.10 Euro x 8760 operating hours / year

Leak related energy costs, source: VDMA “compressed air seminar”

APPLICATION EXAMPLE 1:

Pump monitoring - simultaneous control of more operating conditions

The digital differential transmitter **DE39** in its version with a LC display offers the possibility of displaying the inlet pressure P-, the outlet pressure P+, the differential pressure dP, and the volume flow Q at the same time (functional scheme, illustration 1).

The volume flow Q is calculated in the unit by means of up to 30 value pairs (differential pressure and pertaining volume flow). The value pairs are entered by the user. The corresponding analogue output signal is fed to the pump control enabling the volume flow to be adapted by means of speed adjustment of the pump (illustration 2).

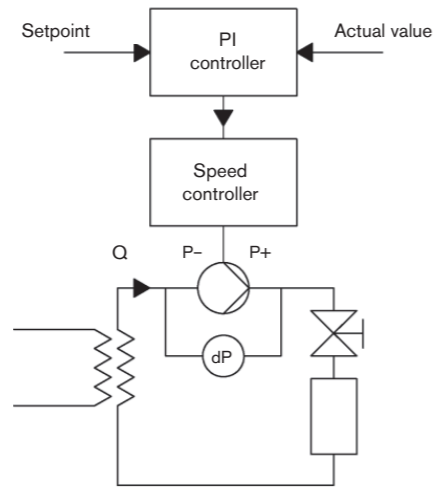

Illustration 1: Functional scheme



DE39 - Digital differential transmitter and switch

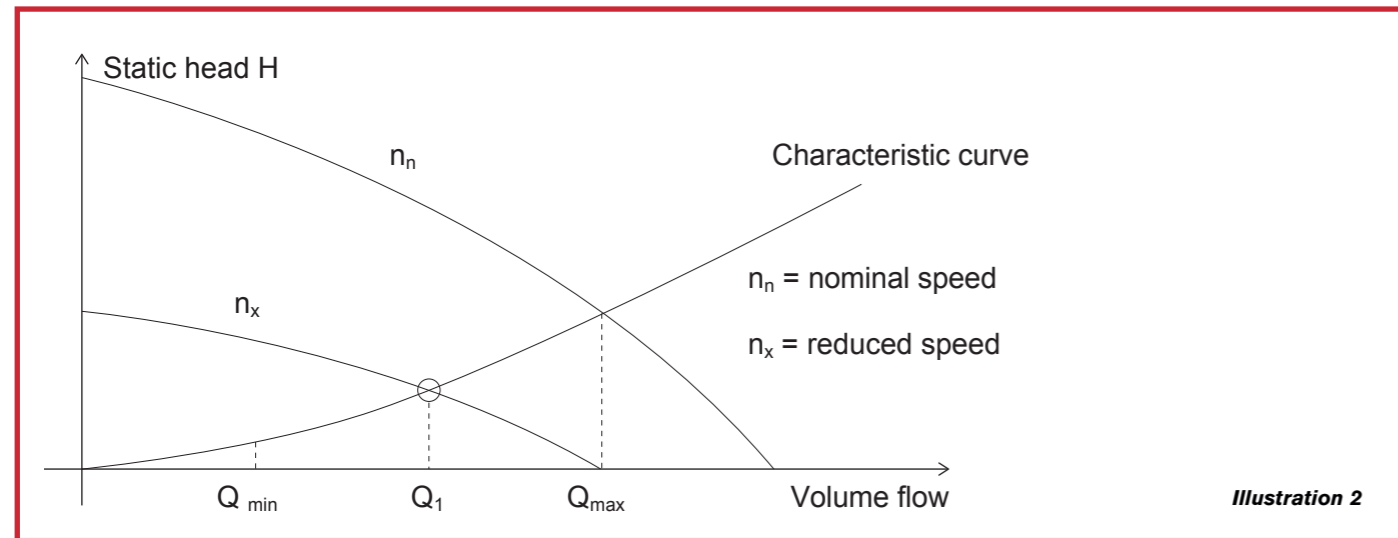
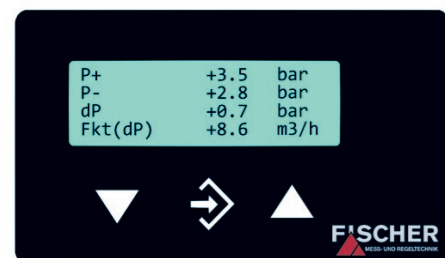

Illustration 2

The above stated measured values serve to view the pump operating status at a glance; the example below shows trouble free operation:



Depending on displaying either differential pressure or the volume flow, different output values are available. Proportional to the display an electric signal on channel 1 as well as a signal proportional to the outlet pressure P+ (alternatively inlet pressure P-, differential pressure dP or volume flow Q) on channel 2. Both potential free switch contacts can be freely assigned to either channel.

Irregular operating conditions:

Irregular operating conditions (e.g. cavitation, closed sliding valve, air in the system) will cause characteristic pressure conditions

to emerge. These can be read directly from the display or assessed by use of the two analogue output signals. In case of a cavitation the outlet pressure P+ will reach inadmissibly high values, the inlet pressure will fall below 0, and the differential pressure dP will be too high.

When operating against a closed sliding valve, both inlet pressure and outlet pressure may rise to unusually high values, with the signal for the outlet pressure P+ becoming too high.

Any air in the system will cause the outlet pressure P+ and consequently the differential pressure dP to strongly fluctuate (output signals changing proportionally).

APPLICATION EXAMPLE 2:

Ventilation control – simultaneous filter- and volume flow monitoring

The **DE44** can be used as a display or switch unit and is equipped with two independent differential pressure sensors and two analogue outputs. It is also designed to measure pressure, negative pressure and differential pressure when using inert gaseous media.

The DE44 can be used for both channels with a root extracted characteristic curve, thus meeting the requirements of a multi-functional unit.

Measurement of several volume flows

The second root extracted characteristic curve serves to record volume flows at different measuring points with simultaneously differently dimensioned measuring ranges, such as supply air, exhaust air or combined for both measuring points. Just like the DE39, the volume flow can be determined and displayed for up to 30 value pairs. Alternatively, the use of one or both channels with

a linear characteristic for monitoring filter systems is also possible.

The unit is particularly suited for applications in the field of energy management as the different features contained in one instrument help to reduce assembly and installation costs.

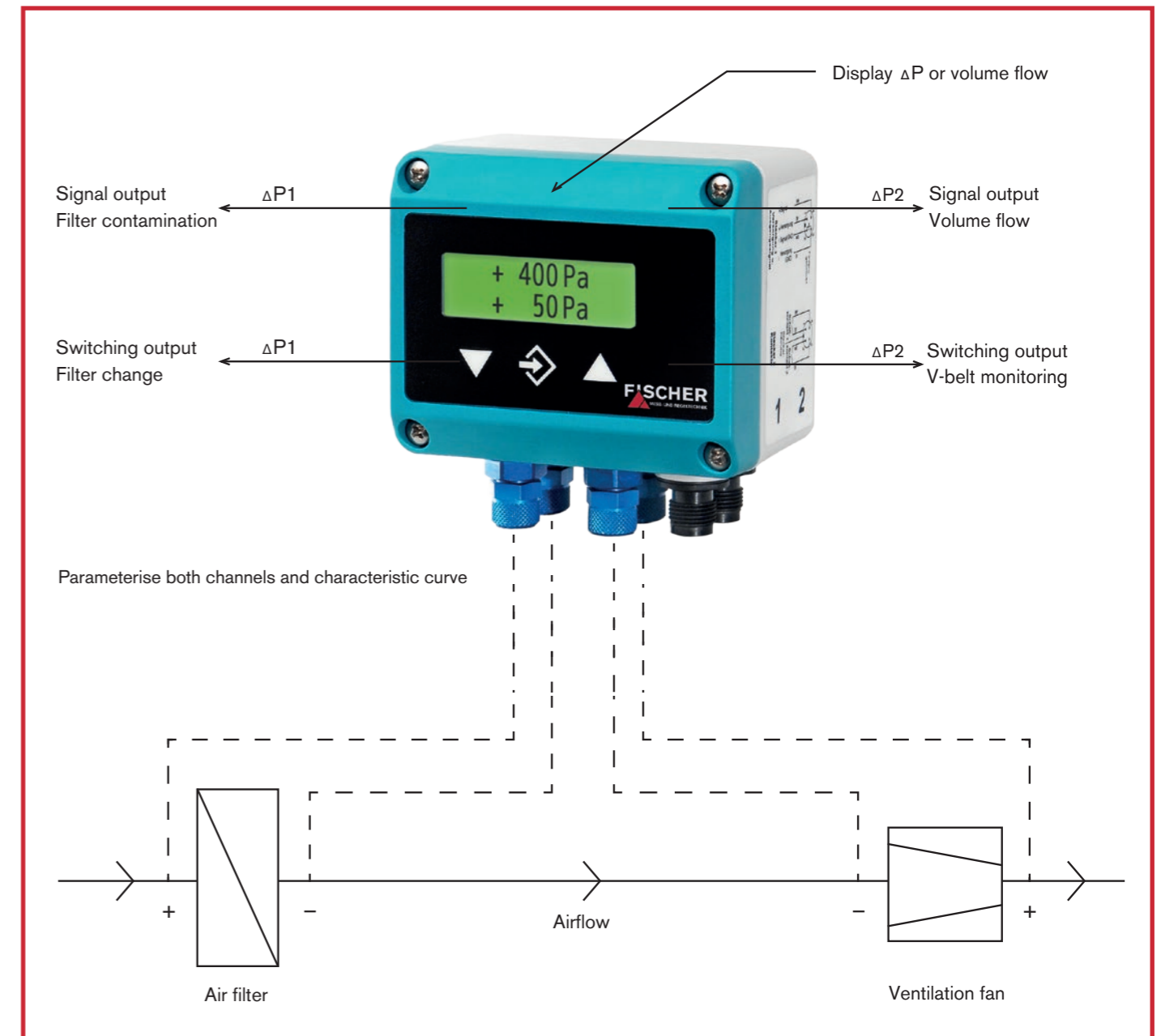

MEASURING DEVICES AND APPLICATIONS

Differential Pressure/Flow



DS31



DE40



DS21



DA03



DE13



DE15



DE70



DE49



DE38



DE39



DE90

- ▲ Operating pressures up to 400 bar
- ▲ Optional with switch contacts and signal output
- ▲ Simple and comfortable menu guidance
- ▲ Extendable for flow measurements
- ▲ Extendable for tank contents measurements
- ▲ Capacitive long-term stable sensors for minimal pressure differences in the Pa range
- ▲ Measurement devices with colour change display for visualisation of operating modes (warning and alarms)
- ▲ DE39 with 2 sensors for differential pressure and optional pressure measurement in pre-run and return in one device
- ▲ DE40 for monitoring of filter and pump systems
- ▲ Measurement device DE44 with 2 sensors for differential pressure (filter) and volume flow measurement as well as switch contacts for filter emergency shutdown
- ▲ DE45 available with hose screw or plug connection
- ▲ DE49 for ATEX zone 1
- ▲ DE90 multifunctional for air and neutral gases

Pressure



MS13



ME50



EA14



ME12



ME67

- ▲ Sensors up to 600 bar
- ▲ Remote parameterisation
- ▲ Parts touching mediums, made of PVDF/PP for highly aggressive mediums
- ▲ MS13 combination of digital pressure transmitter/switch



Various units also available as ex-proof units

AND LOTS MORE ...

Temperature



TW68



TE01



TW85

- ▲ Variations in screw, welding and flange design
- ▲ Thermal elements for high temperatures
- ▲ With and without measurement converter

Filling Level



NK10



NK21



NC57

- ▲ Filling level limiter
- ▲ Continual measurements with reed or capacitive systems
- ▲ Conductive filling level probe with integrated switch contacts !

Calibration Services



- ▲ Calibration on-site Germany or inhouse (FISCHER calibration laboratory)
- ▲ Comprehensive consultation
- ▲ Preparation of calibration certificates
- ▲ Testing of measuring ranges and accuracies after technical consultation
- ▲ Documentation of measuring results

Clean Room Monitoring



- ▲ Humidity / temperature
- ▲ Pressure cascades
- ▲ Visualization of measured values



The New Generation
with sensitive touch display units

FISCHER Mess- und Regeltechnik GmbH supplies an optimally customised model series for these applications.

The measuring instruments are distinguished by:

- ▲ Families of measuring instruments for various measuring tasks
- ▲ Comfortable menu navigation
- ▲ Tables for asymmetric tank containers or flow measurements may be saved
- ▲ Some instruments with extended proofs (EAC, SIL, PLd, DNV GL, EX, structural testing, etc.)
- ▲ Industry-compliant equipment for housings and process connections
- ▲ Special instruments with colour-change displays for visualisation of operating conditions (e.g. warnings, alarms)
- ▲ Extended range with touch-sensitive user interface
- ▲ Customer-specific system solutions

Numerous references from the areas of system planning, system engineering and construction and from operators prove the quality of our products.

FISCHER Mess- und Regeltechnik GmbH offers individual concept solutions for your application.

We are an owner-operated family business with efficient decision-making processes.

We offer our customers tailored systems and product solutions, as well as OEM products.

Our devices and solutions are optimally suited for a variety of applications, such as:

- ▲ Pressure measurement
- ▲ Differential pressure measurement
- ▲ Flow measurement
- ▲ Temperature measurement
- ▲ Level measurement
- ▲ Humidity measurement
- ▲ Control systems

Our sales engineers are available for a detailed consultation regarding our products and solutions. Contact details can be found on our website:

www.fischermesstechnik.de

FISCHER Mess- und Regeltechnik GmbH

Bielefelder Straße 37a · 32107 Bad Salzflen · GERMANY · Fon +49 5222 974-270 · Fax +49 5222 7170
Mail: info@fischermesstechnik.de · Web: www.fischermesstechnik.de